



STAYER

DESIGNED FOR PROFESSIONALS



GENERAL CATALOGUE

PROFESSIONAL TOOLS

2026

STAYER

I + D + I
Laboratory Assembly
line WELDING



**WELCOME
TO STAYER GROUP**



STAYER Technical Service

► **COMPANY 100% SPANISH CAPITAL**, with more than 60 years of experience in the manufacture and distribution of **Power Tools**, **Battery powered tools**, **Welding equipment** and **Abrasive and Diamond Discs**.

We are a team of professionals at the service of our clients, with facilities of more than 20,000m².

In **1958** the brand was born in Italy as a specialist in Power Tools for wood, being the first company to launch a combined mitre saw including an upper table on the market.

In **1976** the distribution began in the Spanish market through Imaport.

At the end of the 90s, STAYER IBERICA, was converted from a distributor to a manufacturer, dominating the entire value chain for the first time, implementing an integrated business model.

In **1999** the first phase of the current facilities was carried out. In **2000**, the diamond blade factory was inaugurated with the most modern technology, including hot pressing

machines and laser welding.

In **2003** the process of expanding the current facilities began, which ended in the following two years.

In **2005**, the assets of the company **STAYER Italy** were acquired, thus becoming **STAYER IBERICA** the manufacturer of the products continuing with the activity of the Italian company.

In **2005 STAYER Italy** was established in the city of Schio, in the province of Vicenza.

At the end of **2020**, the construction of a **new logistics center** began, doubling our storage capacity.

In **2021**, a system with **7 smart vertical storage silos** with 10 meters high is installed.

In **2022** the construction of a new warehouse in Madrid began, improving our logistics.

In July **2022**, a **250-kW** photovoltaic energy system is installed STAYER is committed to sustainability and social responsibility increases.

Warehouses
STAYER

Assembly line
STAYER

Diamond Tools Factory
ABRASIVOS GRINDING



Central Offices
STAYER GROUP



▶ ISO 9001

Stayer is certified for the quality system: product development, analysis laboratory, assembly, product control and distribution, etc., which is proof of the team's commitment to continuous quality improvement..



OUR BUSINESS MODEL



PRODUCT RANGE

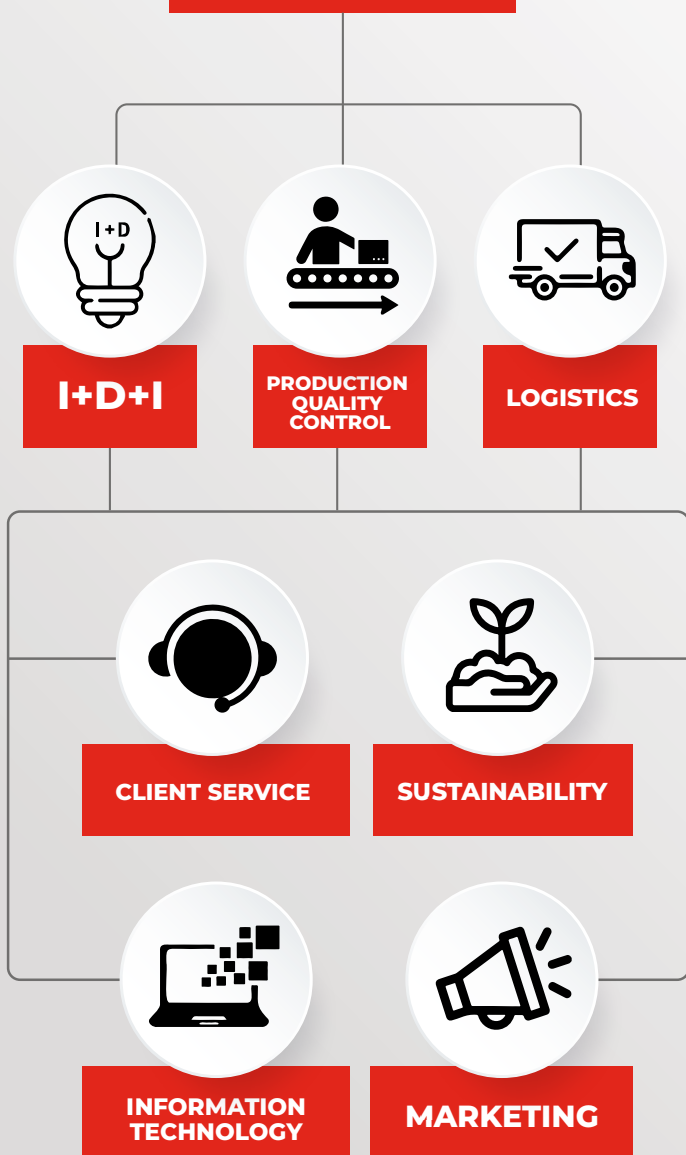

We have an **INTEGRATED** Business model, through which we can **CONTROL** the entire product value chain

The increasingly complex international demand, the rapidity in the evolution of technologies and the most demanding competition, pose the most relevant day-to-day challenges in our company.

Our main purpose is the development of innovation in all areas of the organization, with continuous improvement in our production processes, offering new products that meet the needs of our customers with exclusive, versatile, and durable designs.

Our determination to achieve the perfect symbiosis between Quality and Price is the continuous challenge that we face with the deepest tenacity.

All our equipment is subject to the strictest quality tests in our laboratories with a detailed and constant follow-up always carried out under the supervision of our engineers, verifying by means of state-of-the-art measurement equipment that each one of our creations always comply with the highest European and International Quality Standards.

STAYER goes one step further in its quality controls. For us, quality is not a mere matter of technological, scientific or safety approval by certifying bodies or institutions, but the approval by our clients that each of our equipment meets their expectations under the most severe conditions of real work, subjecting them to rigorous field tests prior to their launch on the market



STAYER

All our prototypes, prior to their commercialization, are subjected by our technical staff to a period of testing and experimentation in our Electronics and Mechanics Laboratory, in which the most demanding pertinent power and resistance tests are carried out, load tests, electromagnetic pollution, etc... necessary, until reaching the highest quality standards that allow us to start production

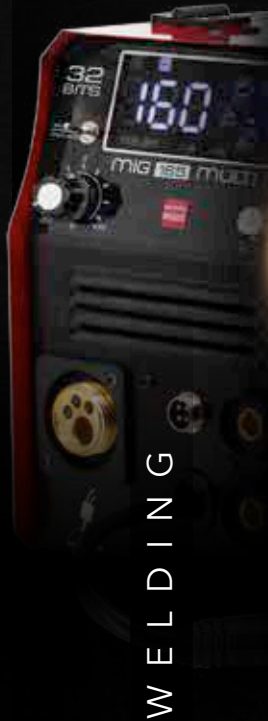

WELDING

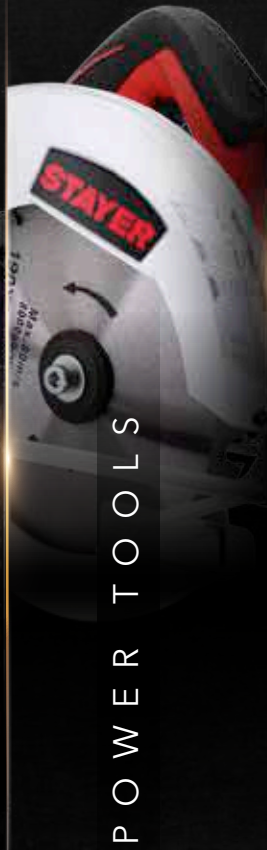

POWER TOOLS



BATTERY TOOLS



DISCS



ACCESSORIES

STAYER establishes programmed quality controls at four points:



1. Selection of components.
2. Assembly.
3. Random test of each production.
4. Benchmarking, which our R&D department develops throughout the life of the product for its continuous improvement and updating.

STAYER



► TECHNICAL OFFICE,

Specialist team: Composed by engineers, electronic and mechanic technicians.

► COMPANY KNOW-HOW

Collaboration agreements with the most prestigious laboratories and certification bodies, for the development and improvement of products: SGS, Dekra, UPM, Nebrija, Carlos III, TÜV.





PRODUCTION

- ▶ **WE ARE SPANISH MANUFACTURERS,** with operating centers in Spain, Portugal, and Asia, in addition to collaborating with international manufacturers, in the development of new products.

We participate in the management of two factories located in Asia, and collaborate with international producers

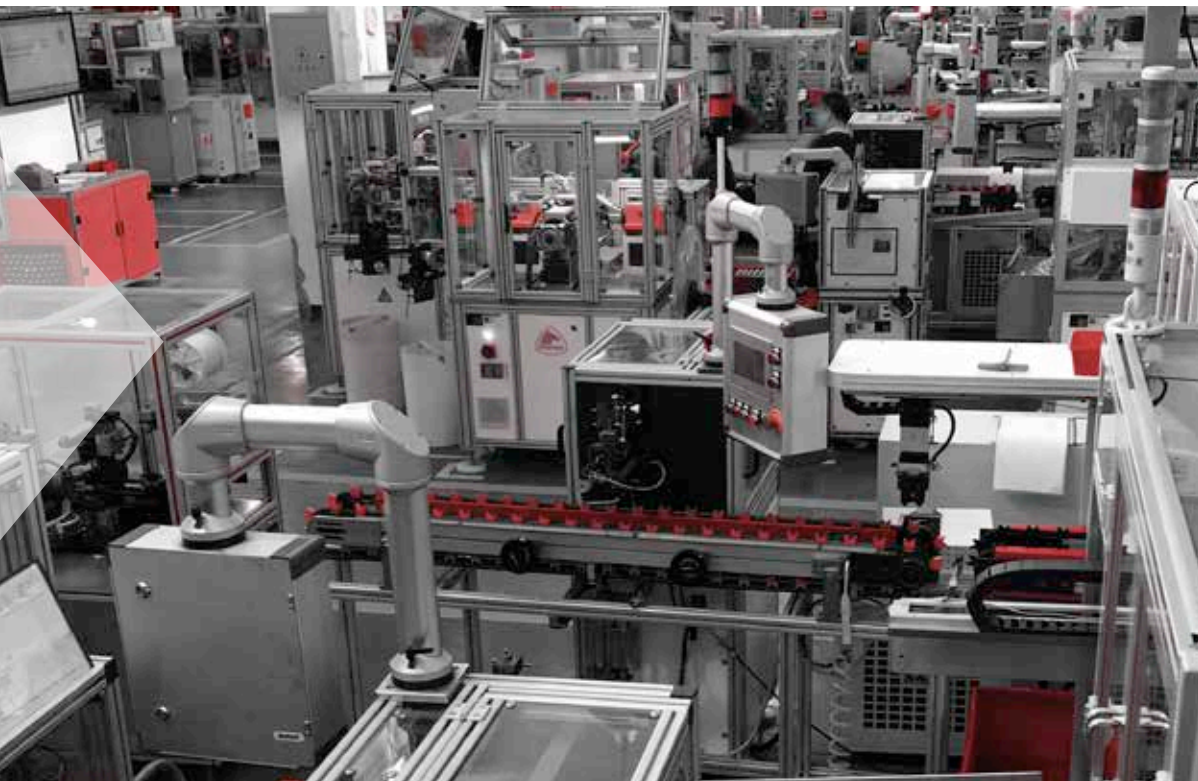

STAYER



- 1.** Development in recent years of small-sized inverter equipment (<2 kg) and professional features, with 100% duty cycle. All this has caused an evolution in the sector that has been very well accepted by professionals.
- 2.** Design of PCB boards, external manufacturing following the guidelines of our R&D department.
- 3.** Assembly of the logic board and verification and graduation of all the equipment in Madrid.
- 4.** Test of 2% of the tested equipment and professional welders in the test area.
- 5.** Level of incidence less than 1% in all welding equipment.



IN OUR LABORATORY our specialized technicians review and adjust each piece of every equipment.

We program our own software developed in Spain and exclusive for our welding equipment, installed on our 32-bit microprocessor.

Specialized engineers oversee improving, updating, testing, and verifying that each component, equipment, and prototype meets the highest quality standards



ABRASIVE DISCS



► **STAYER GROUP** participates in the ownership and management of an abrasive disc factory in Asia, and we are partners of European factories.

Continuous and standardized tests of performance and quality of STAYER discs and those of the competition, which allow us to guarantee the best levels of performance of our discs.

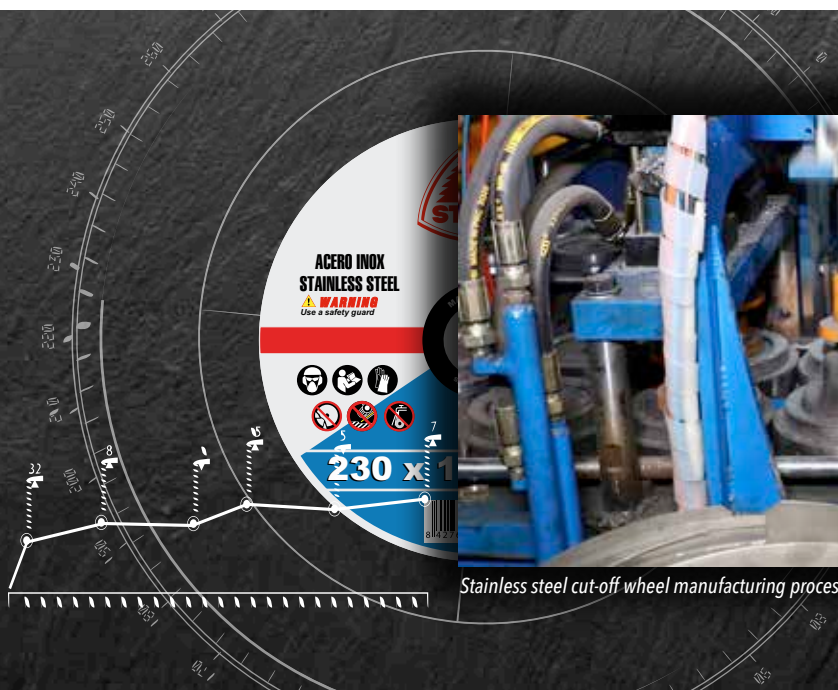

Stainless steel cut-off wheel manufacturing process



**PRODUCTION,
ASSEMBLY and PACKAGING**

Miter saw assembly line

STAYER



Grinder assembly line





► **IN CLOSE COLLABORATION,**

Our Production, Assembly and Packaging departments develop their activities by always using the highest mechanical and electronic components quality.

The R&D department, after designing and testing the quality of the components to be used, gives the green

light to the production and assembly of all our models, which through prior quality control are packaged using the most innovative packaging systems.

All our Production, Assembly and Packaging lines are tested and ergonomically adapted to each job, thus ensuring their perfect adaptation to safety at work and personal care of our employees.



**FACTORY
OF DIAMOND DISCS**

Segment pressing line



New logistics center at C/Transportistas



- 3 logistics centers in Spain
- Capacity for **12.500** pallets
- 7 automated 10m vertical Intelligent Warehouses
- Manage more than **28.000** pieces (to provide speed of service) and ensure immediate delivery.

STAYER

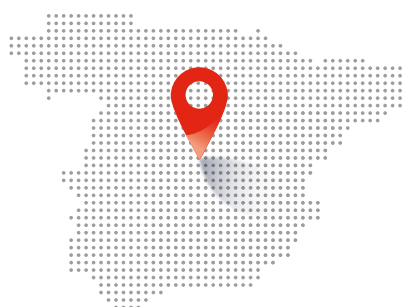

PLUS CODES:

7873+P2 Pinto
67WC+QP Pinto
7896+PG Pinto



Logistics Center C/ Ronda



LOGISTICS



Logistic center C/ Sierra de Cazorra

▶ **OUR MAIN OPERATING CENTER** is integrated with a warehouse, laboratory, and factory. In addition, the entire process from order preparation to picking is automated.

Our ERP, is integrated with the WMS of clients, Online platforms and with the systems of order automation: EDI...

SUSTAINABILITY

DIGITALIZATION

of the departments: Reducing the use of paper, increasing the use of brochures and digital catalogues.

RENEWABLE ENERGIES:

Solar panels that generate 250 kW.

PACKAGING OPTIMIZATION

Reducing the use of cardboard, adjusting the sizes to the maximum.

PLASTIC

We have eliminated or reduced as much as possible the use of non-reusable or non-recycled plastic in our packaging.

LONGER MACHINE LIFESPAN

As we improve our products, we reduce the generation and treatment of waste.

LESS POLLUTION:

We're ditching our range of petrol-powered garden tools for more sustainable battery-powered solutions

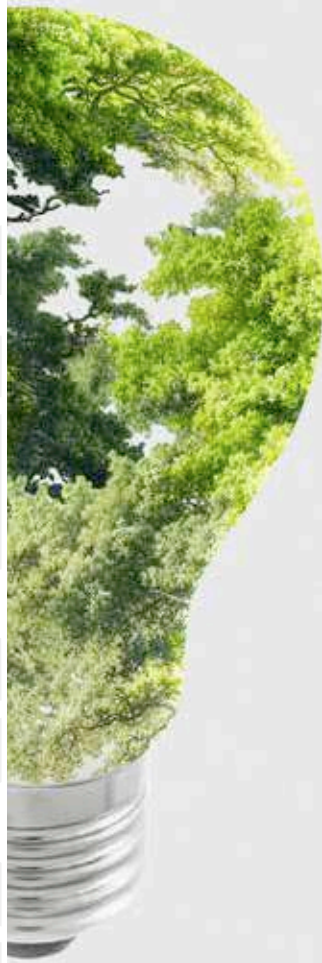

WASTE MANAGEMENT

RECYCLIA: Collection of electrical and electronic waste (WEEE'S) and batteries and accumulators.

ECOEMBES: Collection of cardboard, plastic containers.

SAFETYKLEEN: Chemical.

RECYCLAUTO: Waste from the Diamond discs factory.





STAYER WORLDWIDE

Spain	Luxembourg	Iceland	Uruguay
Portugal	Latvia	Reunion Island	Iraq
Austria	Malta	Israel	Bahrain
Belgium	Poland	Jordan	Peru
Bulgaria	Germany	Lebanon	Tunisia
Cyprus	Romania	Morocco	Benin
Czech Republic	Sweden	Mayotte	Cameroon
Estonia	Slovenia	Mexico	Madagascar
Finland	Saudi Arabia	Norway	Liechtenstein
France	Australia	New Caledonia	Paraguay
Greece	Brazil	Panama	Ar Demr. of Congo
Netherlands	Colombia	French Polynesia	Senegal
Hungary	Ivory Coast xml- ph-0028@	Qatar	Switzerland
Italy	Guatemala	Serbia	Venezuela
Ireland	India	Republic Of Guinea	
Lithuania		Turkey	

▶ **CHASE OF A COMPETITIVE ADVANTAGE** lies in our ability to understand and adapt to the changing dynamics of international markets. We draw on our experience and in-depth knowledge of the different cultures, regulations, and economic trends of the more than 70 countries to which we export.

We work closely with local partners in each country, allowing us to quickly adapt to consumer tastes and preferences in each market. This strategy has allowed us to offer highly relevant and competitive products and services to our international partners, of which 63% are in Europe, 25% in South America, 9% in Africa and 3% in Asia.

Our continue investment in research and development allows us to stay at the forefront of innovation in our industry. We develop advanced products and solutions that meet the specific needs of each international market.

Excellence in supply chain management is also a fundamental pillar of our competitive advantage. We have a global network of first-class logistics providers, which allows us to offer high-quality products in a timely manner and at competitive prices in the more than 70 countries in which we have a presence.

In short, our vision of international development, backed by our extensive experience, translates into a strong and sustainable competitive advantage for Stayer. Through our deep understanding of international markets, our strategic alliances, our capacity for innovation and our excellence in supply chain management, we are ready to excel in an increasingly dynamic global environment.

"Trust STAYER to be your trusted partner in the international growth of your company."





STAYER LAB

► At STAYER

we are reinforcing our commitment to excellence with the inauguration of our new **R&D+i laboratory**, a cutting-edge facility designed to push the durability and safety of our tools to the absolute limit. Our strategic objective is to **"test to improve,"** analyzing the **DNA** of every product before it reaches the market.

The laboratory stands out for its **performance engineering**, utilizing dynamometric equipment to optimize motors and long-duration load benches. In the latter, electric hammers undergo uninterrupted **fatigue tests of up to 48 hours**, allowing us to proactively identify and rectify any mechanical weaknesses.

Regarding **certification technology**, our facilities are equipped with hardware equivalent to that of accredited certification centers. This includes rigorous electrical safety testing (**high voltage and leakage currents**), climatic chambers for welding equipment, and dust chambers to certify **IP protection ratings**. Furthermore, our portable power line undergoes strict **IEC standard protocols** to guarantee battery durability and safety.

This technical deployment is managed by a specialized team of four professionals, experts in **international standards (such as IEC and EPTA)**, ensuring that every measurement is both precise and scientifically sound.

With this investment, we complete the **circle of total quality**. By basing our development on scientific data and extreme stress testing, we do not only comply with European regulations; we provide the professional user with tools featuring a superior service life and guaranteed reliability.



**Battery Tools****Page**
17

18V Battery Tools - L20 Series	18
L20 18V Batteries	44
Stacking Cases, Displays and Carrying Bags	45
12V Battery Tools - L20 Series	47

Drills / Screwdrivers**51**

Screwdriver /Drills	52
Percussion Drills	53
Hammer Drills and Accessories	54

Hammers**55**

SDS-PLUS Rotary Hammers / SDS-PLUS Demolition Hammers	56
SDS-MAX Rotary Hammers / Demolition Hammers SDS-MAX	58
Rotary Hammers / Demolition Hammers - LONG LIFE	60

Painting Works Machines**63**

Paint strippers	65
Mixers	66
Telescopic wall and handheld wall sanders	67
Brushless Paint Spray Gun	70

Angle Grinders**71**

Mini Angle Grinders	72
Industrial Mini Angle Grinders	74
Angle Grinders	75
Angle Grinder Accessories	78

Power Tools: Wood, Metal, Construction**79**

Wall Chasers	80
Saws	82
Sanders, Sanding, Polishing and Milling Machines	87
Buffers, Blowers and Vacuum Cleaners	91

Mitre Saws: Wood, Metal, Construction**95**

Mitre Saws \varnothing 210 mm / \varnothing 250 mm / \varnothing 300 mm	96
Mitre Telescopic Saws	100
Mitre and Band Saws	101

Green Line**104****Other Machines****115**

High Pressure Cleaners	116
Chainsaws, Gasoline-powered Machines	119
Brushcutters, Generators	121

Stayer Accessories**127**



BATTERY TOOLS



Over 200 professional solutions with 18V batteries ranging from 2.0 to 8.0 Ah. Featuring **Stayer Li-ion** technology for protection against overload, overheating, and short circuits, ensuring fast charging and optimal cooling.



DRILL / HAMMER DRILL / SCREWDRIVER 18V

PB 18 B L20 PK

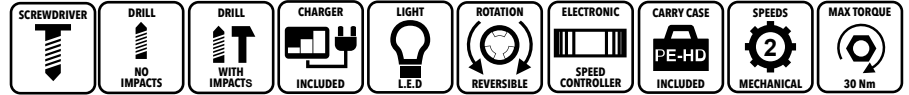

No load speed	0-350 / 0-1350	rpm
Impacts	0-6000 / 0-22500	ipm
Chuck Capacity	ø2 - ø10	mm
Tightening Torque	30	Nm
Settings	25	
Max. wood drilling	ø26	mm
Max. masonry drilling	ø10	mm
Max. steel drilling	ø6	mm
Weight	1	kg

3 Functions:

Drill, Screwdriver & Hammer drill.

- Keyless metal chuck with safety lock.
- Clutch with 25 settings.
- L.E.D. guide light.
- 2 Mechanical speeds.
- Reversible and electronic with microprocessor.



Code

PB 18 B L2022 PK	2 x 2.0Ah	✓	✓	1.3050
-------------------------	------------------	---	---	---------------

DRILL / HAMMER DRILL / SCREWDRIVER 18V

PBL 2022 PK

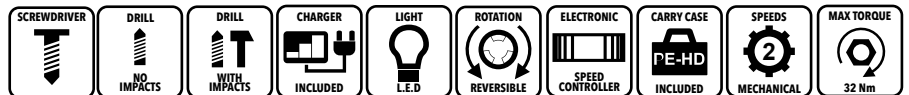

No load speed	0-400 / 0-1350	rpm
Impacts	0-6000 / 21000	ipm
Chuck Capacity	ø2 - ø10	mm
Tightening Torque	32	Nm
Settings	21 + 3	
Max. wood drilling	ø30	mm
Max. masonry drilling	ø10	mm
Max. steel drilling	ø10	mm
Weight	1.2	kg

Cordless drill with 550 Motor.

3 Functions:

Drill, Screwdriver & Hammer drill.

- Keyless Chuck with safety lock.
- Clutch with 21+1+1+1 settings for tightening torque control.
- Belt clip for easy tool hanging between tasks.
- L.E.D. guide light at working area.
- 2 mechanical speeds:
 - Max. torque. Lower reductions.
 - Max. reductions. Lower torque.
- Reversible and electronic with microprocessor.



Code

PBL 2022 PK	2 x 2.0Ah	✓	✓	1.2063
PBL 2022 PKA	2 x 2.0Ah	✓	✓	1.3863

PBL 2022 PKA Includes: Black carry case with accessories.

126 Accessories

DRILL / HAMMER DRILL / SCREWDRIVER 18V

PBL 45 L2022 PK BRUSHLESS

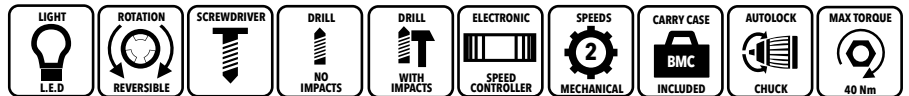

No load speed	0-400 / 0-1400	rpm
Impacts	6000 - 21000	ipm
Chuck Capacity	ø1 - ø10	mm
Tightening Torque	45	Nm
Settings	22 + 1	
Max. wood drilling	ø40	mm
Max. masonry drilling	ø10	mm
Max. steel drilling	ø10	mm
Weight	1.2	kg

- **BRUSHLESS motor** (increased performance and service life.)
- **3 Functions:**
- **Drill, Screwdriver & Hammer drill.**
- **Metal drill chuck.**



Code

PBL 45 L2022 BRUSHLESS	2 x 2.0Ah	✓	✓	1.3958
-------------------------------	------------------	---	---	---------------

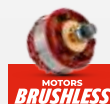

DRILL / HAMMER DRILL / SCREWDRIVER - 18V

PBL 50 BRUSHLESS L20



No load speed	0-450 / 0-1550	rpm
Impacts	0-6750 / 0-23250	ipm
Chuck Capacity	ø2 - ø13	mm
Tightening Torque	50	Nm
Settings	20 + 3	
Max. wood drilling	ø45	mm
Max. masonry drilling	ø13	mm
Max. steel drilling	ø13	mm
Weight	1.0	kg

- **BRUSHLESS motor** (increased performance and service life.)

- **3 Functions:**

Drill, Screwdriver & Hammer drill.



⚡ 🔋 PE-HD **Code**

PBL 50 BRUSHLESS	X	X	X	1.3059
PBL 50 2022 PK BRUSHLESS	2 x 2.0Ah	✓	✓	1.2964
PBL 50 2024 PK BRUSHLESS	2 x 4.0Ah	✓	✓	1.2965
PBL 50 2025 PK BRUSHLESS	2 x 5.0Ah	✓	✓	1.2966



DRILL / HAMMER DRILL / SCREWDRIVER - 18V

PBL 70 B BRUSHLESS L20



No load speed	0-450 / 0-1700	rpm
Impacts	0-7500 / 0-30000	ipm
Chuck Capacity	ø13	mm
Tightening Torque	70	Nm
Settings	20+1	
Max. wood drilling	ø45	mm
Max. masonry drilling	ø16	mm
Max. steel drilling	ø13	mm
Weight	1.2	kg

NEW
Check Availability

- **BRUSHLESS motor** (increased performance and service life.)

- **3 Functions:**

Drill, Screwdriver & Hammer drill.

- Automatic metal chuck with safety lock 13mm.

- Clutch with 20+1 setting.

- L.E.D. guide light.

⚡ 🔋 PE-HD **Code**

PBL 70 B L20 BRUSHLESS	X	X	X	1.4556
PBL 70 B 2022 BRUSHLESS	2 x 2.0 Ah	✓	✓	1.4557
PBL 70 B 2024 BRUSHLESS	2 x 4.0 Ah	✓	✓	1.4558

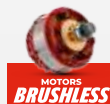

DRILL / HAMMER DRILL / SCREWDRIVER - 18V

PBL 80 P L20 BRUSHLESS



No load speed	0-500 / 0-2000	rpm
Impacts	0-7500 / 0-30000	ipm
Chuck Capacity	ø1.5 - 13	mm
Tightening Torque	80	Nm
Settings	20+3	
Max. wood drilling	ø50	mm
Max. masonry drilling	ø16	mm
Max. steel drilling	ø16	mm
Weight	1.2	kg

- **BRUSHLESS motor** (increased performance and service life.)

- **3 Functions:**

Drill / Screwdriver / Percussion.

Large torque: **80Nm**

- **Automatic metal chuck with** 13mm safety lock.

- **STAYER Li-ion HIGH-TECH, L20 battery** with overcharge, battery discharge, overheating and short circuit protection. LED charge indicator.

- **LED guide light.**

⚡ 🔋 PE-HD **Code**

PBL 80 P - L20 BRUSHLESS	X	X	X	1.2903
PBL 80 P - L2022 BRUSHLESS	2 x 2.0Ah	✓	✓	1.3263
PBL 80 P - L2024 BRUSHLESS	2 x 4.0Ah	✓	✓	1.3264
PBL 80 P - L2025 BRUSHLESS	2 x 5.0Ah	✓	✓	1.3265



DRILL / HAMMER DRILL / SCREWDRIVER - 18V

PBL 100 P L20 BRUSHLESS

No load speed	0 - 450 / 0 - 1900	rpm
Impacts	0 - 7200 / 0 - 32000	ipm
Chuck Capacity	ø1.5 / 13	mm
Tightening Torque	100	Nm
Settings	20 + 3	
Max. wood drilling	52	mm
Max. masonry drilling	16	mm
Max. steel drilling	16	mm
Weight	1.3	kg

Code

PBL 100 P - L20	X	X	X	1.3873
PBL 100 P - L2022	2 x 2.0Ah	✓	✓	1.3918
PBL 100 P - L2024	2 x 4.0Ah	✓	✓	1.3919
PBL 100 P - L2025	2 x 5.0Ah	✓	✓	1.3948
PBL 100 P - L2026	2 x 6.0Ah	✓	✓	1.3959

LIGHT
L.E.D

ROTATION
REVERSIBLE

SCREWDRIVER

DRILL
NO IMPACTS

DRILL
WITH IMPACTS

ELECTRONIC
SPEED CONTROLLER

SPEEDS
MECHANICAL

AUTOLOCK
CHUCK

MAX TORQUE
100 Nm

- **BRUSHLESS motor** (increased performance and service life.)

- **3 Functions:**

- **Drill / Screwdriver / Percussion**

- Large torque: **100Nm** and a powerful **BRUSHLESS motor**, brushless.

- Automatic metal chuck with 13mm safety lock.

- **Clutch with 20 settings + 3 adjustment functions**

- **2 mechanical speeds.**

- **STAYER Li-ion HIGH-TECH, L20 battery** with overcharge, battery discharge, overheating and short circuit protection. LED charge indicator.

- **LED guide light.**



KICK BACK CONTROL

DRILL / HAMMER DRILL / SCREWDRIVER - 18V

PBL 130 L20

No load speed	0-500 / 0-2250	rpm
Impacts	0-7500 / 0-3300	ipm
Chuck Capacity	ø 1.5 / 13	mm
Tightening Torque	130	Nm
Settings	20+3	
Max. wood drilling	ø55	mm
Max. masonry drilling	ø16	mm
Max. steel drilling	ø16	mm
Weight	1.6	kg

Code

PBL 130 P	X	X	X	1.4470
PBL 130 P L2022	2 x 2.0Ah	✓	✓	1.4559
PBL 130 P L2024	2 x 4.0Ah	✓	✓	1.4560
PBL 130 P L2025	2 x 5.0Ah	✓	✓	1.4561

NEW
Check Availability

- **BRUSHLESS motor** (increased performance and service life.)

- **3 Functions:**

- **Drill / Screwdriver / Percussion**

- Large torque: **130Nm** and a powerful **BRUSHLESS motor**, brushless.

- Automatic metal chuck with 13mm safety lock.

- **Clutch with 20 settings + 3 adjustment functions**

- **2 mechanical speeds.**

LIGHT
L.E.D

ROTATION
REVERSIBLE

SCREWDRIVER

DRILL
NO IMPACTS

DRILL
WITH IMPACTS

ELECTRONIC
SPEED CONTROLLER

SPEEDS
MECHANICAL

AUTOLOCK
CHUCK

MAX TORQUE
130 Nm

- **STAYER Li-ion HIGH-TECH, L20 battery** with overcharge, battery discharge, overheating and short circuit protection. LED charge indicator.

- **LED guide light.**



KICK BACK CONTROL

DRILL / HAMMER DRILL / SCREWDRIVER 18V

PBL 150 P L20 BRUSHLESS

No load speed	0-500 / 0-2100	rpm
Impacts	0-7500 / 0-35000	ipm
Chuck Capacity	ø1.5 - 13	mm
Tightening Torque	150	Nm
Settings	20+3	
Max. wood drilling	ø60	mm
Max. masonry drilling	ø16	mm
Max. steel drilling	ø20	mm
Weight	1.6	kg

Code

PBL 150 P - L20	X	X	X	1.2904
PBL 150 P - L2022	2 x 2.0Ah	✓	✓	1.2967
PBL 150 P - L2024	2 x 4.0Ah	✓	✓	1.2968
PBL 150 P - L2025	2 x 5.0Ah	✓	✓	1.2969
PBL 150 P - L2026	2 x 6.0Ah	✓	✓	1.3266

LIGHT
L.E.D

ROTATION
REVERSIBLE

SCREWDRIVER

AUTO-STOP
SYSTEM

DRILL
NO IMPACTS

DRILL
WITH IMPACTS

ELECTRONIC
SPEED CONTROLLER

SPEEDS
MECHANICAL

AUTOLOCK
CHUCK

MAX TORQUE
150 Nm

- **BRUSHLESS motor** (increased performance and service life.)

- **3 Functions:**

- **Drill / Screwdriver / Percussion,**

- Large torque: **150Nm** and a powerful **BRUSHLESS motor**, brushless.

- Automatic metal chuck with 13mm safety lock.

- **Clutch with 20 settings + 3 adjustment functions**

- **2 mechanical speeds**

- **STAYER Li-ion HIGH-TECH, L20 battery** with overcharge, battery discharge, overheating and short circuit protection. LED charge indicator.

- **LED guide light.**

- Auxiliary handle.

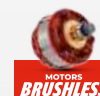

KICK BACK CONTROL

IMPACT SCREWDRIVER 200Nm 18V - 1/4"

IS 200 L20

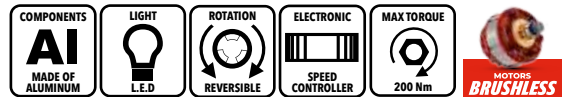

No load speed	0 - 930 / 0 - 2700 / 0 - 3350	rpm
Impacts	0 - 2500 / 0 - 3500 / 0 - 4500	ipm
Insertion	1/4"	UNF
Tightening Torque	90 / 160 / 200	Nm
Weight	0.9	kg

NEW
Check Availability



				Code
IS 200 L20	X	X	X	1.4469
IS 200 L2022	2 x 2.0Ah	✓	✓	1.4562
IS 200 L2024	2 x 4.0Ah	✓	✓	1.4563
IS 200 L2025	2 x 5.0Ah	✓	✓	1.4564

- **BRUSHLESS motor** (increased performance and service life.)

- **18 V, 1/4"** battery powered impact screwdriver, torque 200 Nm.

- **3 settings** combining speed and impacts:

MODE 1: 0 - 930 rpm / 0 - 2500 ipm

MODE 2: 0 - 2700 rpm / 0 - 3500 ipm

MODE 3: 0 - 3350 rpm / 0 - 4500 ipm

- Variable speed adjustment switch. Reversible.

- **Powerful brushless motor.**

- **STAYER Li-ion HIGH-TECH, L20 battery** with overcharge, battery discharge, overheating and short circuit protection. LED charge indicator.

- **LED guide light.**

IMPACT SCREWDRIVER 230Nm 18V - 1/4"

IS 230 B L20 BRUSHLESS

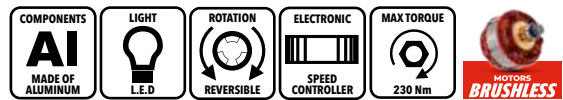

No load speed	0-1300 / 0-1800 / 0-2500 / 0-3200	rpm
Impacts	0-1700 / 0-2200 / 0-2900 / 0-3600	ipm
Insertion	1/4"	UNF
Tightening Torque	90 / 150 / 180 / 230	Nm
Weight	0.9	kg

NEW
Check Availability



				Code
IS 230 B L20	X	X	X	1.4441
IS 230 B L2022	2 x 2.0Ah	✓	✓	1.4566
IS 230 B L2014	1 x 4.0Ah	✓	✓	1.4567
IS 230 B L2024	2 x 4.0Ah	✓	✓	1.4569
IS 230 B L2025	2 x 5.0Ah	✓	✓	1.4572

- 9 working modes**
- Anti-drop protection**
- Quick bit release**

- **BRUSHLESS motor** (increased performance and service life.)

- **18 V, 1/4"** battery powered impact screwdriver, torque 230 Nm, 9 working modes.

- **4 settings** combining speed, impacts and torque (green color)

- **3 Tightening Functions** (red color)

- **2 Loosening Functions**

• **Continuous mode** (no LED active)

• **Automatic stop mode** (red LED on)

- **Variable speed adjustment switch.** Reversible.

- **Self-release bit holder:**

- **Powerful brushless motor.**

- **STAYER Li-ion HIGH-TECH, L20 battery** with overcharge, battery discharge, overheating and short circuit protection. LED charge indicator.

- **LED guide light.**

CORDLESS GRINDER COMPARISON CHART

ACTION	AGR L20	AGBR L20	AGBX L20	AGB PS L20	AGB EXTREME L20	AGB 125 DT
Code	1.4472	1.3330	1.3235	1.3597	1.3874	1.4183
Brushless Motor	✓	✓	✓	✓	✓	✓
Trigger Type	Double Upper Step	Trigger	Double Upper Step	Paddle Switch	Paddle Switch	Double Upper Step
Variable Speed	✓	✓	X	X	✓	✓
Quick-Adjust Guard	X	X	✓	✓	✓	✓
Adjustable Handle	2 Sides	2 Sides	2 Sides	2 Sides	2 Sides	2 Sides
Handle with Anti-Vibration System	X	X	X	X	✓	X
Compatible with Cutting and Grinding Guards	✓	✓	✓	✓	✓	✓
NVR Safety Switch	✓	✓	✓	✓	✓	✓
Slim Body Design	✓	✓	✓	✓	✓	✓
Brake Time <2" (Full Power)	✓	X	✓	✓	✓	✓
Soft Start	✓	✓	✓	✓	✓	✓
Optimized Cooling with Metal Mesh	X	X	✓	✓	✓	X
Speed Control Dial for Constant Speed	X	X	X	X	✓	✓
Anti-Lock System	X	X	✓	✓	✓	✓

ANGLE GRINDER 18V

AGBN L20

No load speed	0 - 9200	rpm
Disc diameter	115	mm
Insertion	M14	
Weight	1,5	kg

NEW
Check Availability



				Code
AGBN L20	X	X	✓	1.4472
AGBN L2024	2 x 4.0Ah	✓	✓	1.4586
AGBN L2025	2 x 5.0Ah	✓	✓	1.4587

BRUSHLESS ANGLE GRINDER 18V

AGBR L20 BRUSHLESS

No load speed	0 - 8500	rpm
Disc diameter	115	mm
Insertion	M14	
Weight	1.5	kg



				Code
AGBR L20	X	X	✓	1.3330
AGBR L2024	2 x 4.0Ah	✓	✓	1.3628
AGBR L2025	2 x 5.0Ah	✓	✓	1.3629

- **BRUSHLESS motor** (increased performance and service life.)
- **Angle grinder 115 mm.**
- **Adjustable handle** on both sides and on the head, narrow and ergonomic grip, for greater comfort.
- **STAYER Li-ion HIGH-TECH, L20 battery** with overcharge, battery discharge, overheat and short circuit protection. LED guide light.

BRUSHLESS ANGLE GRINDER 18V

AGBX L20

AGBX ø115 AGBX ø125

No load speed	9000	9000	rpm
Disc diameter	ø115	ø125	mm
Insertion	M14	M14	
Weight	1.3	1.3	kg

Code

AGBX L20	X	X	X	1.3235
AGBX L2014 Set	1 x 4.0Ah	✓	✓	1.3288
AGBX L2015 Set	1 x 5.0Ah	✓	✓	1.3290
AGBX L2024 Set	2 x 4.0Ah	✓	✓	1.3291
AGBX L2025 Set	2 x 5.0Ah	✓	✓	1.3292
AGBX L2026 Set	2 x 6.0Ah	✓	✓	1.3293

POWER 18 V NO LOAD SPEED 9000 rpm SPINDLE THREAD M14 SOFT START ANTI RESTART SWITCH 1000 W

ULTRALIGHT



- **BRUSHLESS motor** (increased performance and service life.)
- **STAYER Li-ion HIGH-TECH, L20 battery** with overcharge, battery discharge, overheating and short circuit protection. LED charge indicator.
- **Braking system in less than 2 seconds.**
- Cooling system with protection grids.
- Soft start.

Code

AGBX 125 L2024 Set	2 x 4.0Ah	✓	✓	1.3282
AGBX 125 L2025 Set	2 x 5.0Ah	✓	✓	1.4118

BRUSHLESS ANGLE GRINDER 18V

AGB PS L20

AGB PS ø115 AGB PS ø125

No load speed	0-8500	0-8500	rpm
Disc diameter	ø115	ø125	mm
Insertion	M14	M14	
Weight	1.7	1.7	kg

AGB PS L20 **Code**

AGB PS L20	X	X	X	1.3597
AGB PS L2024	2 x 4.0Ah	✓	✓	1.3907
AGB PS L2025	2 x 5.0Ah	✓	✓	1.3929
AGB PS L2026	2 x 6.0Ah	✓	✓	1.3981

AGB PS 125 L20 **Code**

AGB PS 125 L2024	2 x 4.0Ah	✓	✓	1.3984
AGB PS 125 L2025	2 x 5.0Ah	✓	✓	1.3983
AGB PS 125 L2026	2 x 6.0Ah	✓	✓	1.3982

POWER 18 V NO LOAD SPEED 0-8500 rpm PADDLE SWITCH INTERRUPTOR PALA SPINDLE THREAD M14 SOFT START FAST CHANGE ANTI RESTART SWITCH 1200 W



- **BRUSHLESS motor** (increased performance and service life.)
- **Electronic constant speed system**
- **STAYER Li-ion HIGH-TECH, L20 battery** with overcharge, battery discharge, overheating and short circuit protection. LED charge indicator.
- **Braking system in less than 2 seconds**
- Cooling system with protection grids
- Soft start

BRUSHLESS ANGLE GRINDER 18V

AGB XTREME PS L20

No load speed	2500 - 10000	rpm
Disc diameter	115 / 125	mm
Insertion	M14	
Weight	1.7	kg

AGB XTREME PS L20 **Code**

AGB XTREM L20	X	X	X	1.3874
AGB XTREM L2024	2 x 4.0Ah	✓	✓	1.3975
AGB XTREM L2025	2 x 5.0Ah	✓	✓	1.3976
AGB XTREM L2026	2 x 6.0Ah	✓	✓	1.3977

AGB XTREME PS 125 L20 **Code**

AGB XTREM 125 L20	X	X	X	1.4027
AGB XTREM 125 L2024	2 x 4.0Ah	✓	✓	1.3978
AGB XTREM 125 L2025	2 x 5.0Ah	✓	✓	1.3979
AGB XTREM 125 L2026	2 x 6.0Ah	✓	✓	1.3980

POWER 18 V NO LOAD SPEED 2500-10000rpm PADDLE SWITCH INTERRUPTOR PALA SPINDLE THREAD M14 SOFT START FAST CHANGE ANTI RESTART SWITCH ELECTRONIC (ABS) BRAKE ELECTRONIC SPEED CONTROLLER CARTER DETACHABLE FAST CHANGE 1500 W

NEW
Check Availability



Anti-vibration Handle



Digital Variable Speed



AGB 125 DT

BRUSHLESS ANGLE GRINDER 18V

BRUSHLESS

DIRECT TRANSMISSION

Encapsulated motor design with perfect dust-proof performance, suitable for a variety of difficult working conditions and with a long service life.

Silent



2-STEP SAFETY SWITCH

SLIM BODY DESIGN FOR ONE-HANDED OPERATION

STOP SENSOR WHEN A FALL IS DETECTED

ENCAPSULATED MOTOR. COOLING SYSTEM

BRUSHLESS ANGLE GRINDER 18V

AGB 125 DT L20

No load speed	4000 / 6500 / 9200	rpm
Disc diameter	125	mm
Insertion	M14	
Weight	0.9	kg

POWER 18 V	NO LOAD SPEED 0 - 9200 rpm	SPINDLE THREAD M14	VARIABLE SPEED	SOFT START	1200 w
----------------------	--------------------------------------	------------------------------	-----------------------	-------------------	---------------



DIRECT TRANSMISSION



Silent

Code

AGB 125 DT L20	X	X	X	1.4183
AGB 125 DT L2024 Set	2 x 4.0Ah	✓	✓	1.4413
AGB 125 DT L2025 Set	2 x 5.0Ah	✓	✓	1.4414

- **BRUSHLESS motor** (increased performance and service life.)
- **Angle grinder 125 mm.**
- **Adjustable handle** on both sides and on the head, narrow and ergonomic grip, for greater comfort.
- **STAYER Li-ion HIGH-TECH, L20 battery** with overcharge, battery discharge, overheat and short circuit protection. LED guide light.



NEW
Check Availability

ROTARY HAMMER 18V

HDB PRO-LITE L20

No load speed	0 - 810	rpm
Impacts	0 - 4500	ipm
Insertion	SDS - PLUS	
Impact energy	1.5	J
Max. masonry drilling	20	mm
Max. wood drilling	13	mm
Max. steel drilling	8	mm
Weight	1.5	kg

Code

HDB PRO-LITE L20	X	X	X	1.3960
HDB PRO-LITE L2022	2 x 2.0Ah	✓	✓	1.3992
HDB PRO-LITE L2014	1 x 4.0Ah	✓	✓	1.3993
HDB PRO-LITE L2024	2 x 4.0Ah	✓	✓	1.3994
HDB PRO-LITE L2025	2 x 5.0Ah	✓	✓	1.3995

NEW
Check Availability

ULTRALIGHT



- BRUSHLESS motor (increased performance and service life.)

2 Functions:

1. Rotary: for metal, wood & plastic.
 2. Rotary with percussion: for construction materials.
- Reversible.
 - Electronic tightening torque and safety clutch.
 - Rotary and Impact drilling for an optimal performance.
 - L.E.D guide light.
 - Auxiliary handle.



ROTARY HAMMER 18V

HDB C L20 BRUSHLESS

No load speed	0-1200	rpm
Impacts	0-5300	ipm
Insertion	SDS PLUS	
Impact energy	2.8	J
Max. masonry drilling	ø26	mm
Max. wood drilling	ø30	mm
Max. steel drilling	ø13	mm
Weight	2.5	kg

Code

HDB C L20	X	X	X	1.4473
HDB C L2014	1 x 4.0Ah	✓	✓	1.4582
HDB C L2024	2 x 4.0Ah	✓	✓	1.4583
HDB C L2025	2 x 5.0Ah	✓	✓	1.4584
HDB C L2026	2 x 6.0Ah	✓	✓	1.4585

NEW
Check Availability



- BRUSHLESS motor (increased performance and service life.)

4 functions:

1. Rotary drilling: for metal, wood, and plastic.
 2. Hammer drilling: for construction materials.
 3. Chiseling: for construction materials.
 4. Vario-lock: adjusts the chisel position.
- Reversible.
 - Variable speed.
 - Auxiliary handle.



ROTARY HAMMER 18V

HD X FORCE L20

No load speed	0-1200	rpm
Impacts	0-5200	ipm
Insertion	SDS PLUS	
Impact energy	4.5	J
Max. masonry drilling	ø26	mm
Max. wood drilling	ø40	mm
Max. steel drilling	ø13	mm
Weight	3.5	kg

Code

HD X FORCE L20	X	X	X	1.3552
HD X FORCE L2024	2 x 4.0Ah	✓	✓	1.3460
HD X FORCE L2025	2 x 5.0Ah	✓	✓	1.3461
HD X FORCE L2026	2 x 6.0Ah	✓	✓	1.3462

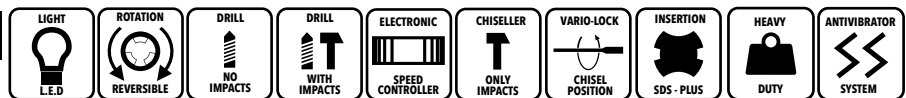

HEAVY DUTY

- Safety clutch.
- 360° adjustable handle.
- Equivalent electric hammer 1500W and 5J.
- Optimum cooling.
- HEAVY DUTY
- Quick change.
- Auxiliary handle.

4 functions

- 1- Rotary with percussion.
- 2- Chiselling: for construction materials.
- 3- Vario-lock: to control the chisel position
- 4- Rotary



NAIL GUN

NG 06 L20 BRUSHLESS

Nail diameter	0.6	mm
Nail length	12 - 18 - 25 - 30 - 35	mm
Screw-in gauge	23	Ga
Nail loader capacity	120	
Weight	2.0 - 2.3	kg



NG 06 L20	X	X	X	1.4000
NG 06 L2022	2 x 2.0Ah	✓	✓	1.4043
NG 06 L2024	2 x 4.0Ah	✓	✓	1.4044

BOX OF 5.000 PIN NAILS

ø0.6 - 25 mm
Code 12.1169

ø0.6 - 30 mm
Code 12.1178

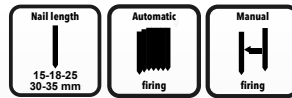

NEW
Check Availability



- **18V battery powered Nail Gun** with a powerful BRUSHLESS motor.
- **Lightweight and easy to handle**, reducing fatigue during prolonged use.
- **STAYER Li-ion HIGH-TECH, L20** battery with overcharge, battery discharge, overheating and short circuit protection.
- **LED** charge indicator.
- **Belt clip** for easy tool hanging between tasks.
- **For 0.6mm headless pin nails.**
- Double safety system.
- **Safety sensor** in the tip to prevent unintentional firing.
- **Manual safety switch lock.**



TILES VIBRATOR

TV L20 B

Suction cup diameter	123	mm
Maximum capacity	60	kg
Vibration frequency	12	Tipos
Weight	1.22	kg



TV L20 B	X	X	X	1.4598
TV L2022 Set	2 x 2.0Ah	✓	✓	1.4458

- **Strong suction force:** 50 kg clamping capacity for tiles and slabs, ceramic, stoneware, porcelain, granite and marble.
- **Suitable for wall tiles, small floor tiles:** for moving and relocating floor and wall tiles, which significantly improves work efficiency

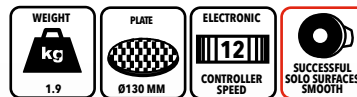

- **One-button vibration, uniform force:** to adjust the vibration frequency to the size of the brick, correct the position of the brick and improve efficiency
- **Non-slip handle:** stable and safe operation.
- Aluminum head.
- Locking clamping button.



DUAL MIXER 18V

DM L20

No load speed	0-600 / 0-900	rpm
Insertion	M18	
Upper whisk	ø120	mm
Lower whisk	ø95	mm
Whisk Length	600	mm
Weight	4.5	kg



DM L20	X	X	X	1.2233
DM L2012 Set	1 x 2.0Ah	✓	X	1.2529
DM L2022 Set	2 x 2.0Ah	✓	X	1.2234
DM L2024 Set	2 x 4.0Ah	✓	X	1.2235

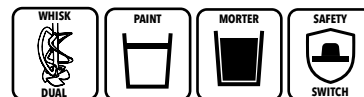

- **Double whisk with inverse rotation**
- Upper whisk spins rightwise.
- Lower whisk spins leftwise
- 2 Mechanical speeds for better mixing
- Speed regulator

Optional

- Adapter M18 to M14 Code 12.295



DRY WALL SCREWDRIVER BRUSHLESS 18V

DWS L20

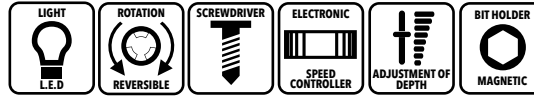

No load speed	0-4400	rpm
Insertion	1/4"	UNF
Tightening Torque	4	Nm
Weight	1	kg

							Code
DWS L20	X	X	X				1.2580
DWS L2012 K	1 x 2.0Ah	✓	Carrying bag				1.3335
DWS L2022 K	2 x 2.0Ah	✓					1.2581
DWS L2014 K	1 x 4.0Ah	✓	Carrying bag				1.3337
DWS L2024 K	2 x 4.0Ah	✓	Carrying bag				1.2680

- **BRUSHLESS motor** (increased performance and service life.)
- Powerful brushless motor for increased efficiency, significantly reducing heat build-up and considerably increasing motor life and battery life.
- **STAYER Li-ion HIGH-TECH, L20** battery with protection against overcharge, battery discharge, overheating, short circuit. LED charge indicator.
- Designed for plasterboard panels.
- Reversible switch with speed control.
- Instantaneous electronic brake when switch is released.
- Head with depth adjustment.
- **L.E.D. guide light.**



SPECIAL FOR DRYWALLS



UNIVERSAL PLASTERBOARD TAPE SCREWS
- 1000 pcs / 20 strips - 50 screws

- 3.25 x 25 mm Code 12.969
- 3.25 x 35 mm Code 12.970

ACCESSORY FOR PLASTERBOARD SCREWDRIVER

SCREW FEEDER FOR DWS L20

Code 1.3083



- **Long Tip 100 mm - Code 8293.1174**
- Screw feeder for DWS L20 plasterboard screwdriver.
- Adaptable depth regulator.
- Very light 0.33Kg.
- Length regulator from 25mm to 55mm screws.
- Several positions to improve the user's comfort when screwing.
- Easy and fast screw string placement.

SCREW DRIVER AND SCREW FEEDER



				Code
DWS L2012 + Feeder	1 x 2.0Ah	✓	✓	1.3176
DWS L2022 + Feeder	2 x 2.0Ah	✓	✓	1.3441
DWS L2014 + Feeder	1 x 4.0Ah	✓	✓	1.3178
DWS L2024 + Feeder	2 x 4.0Ah	✓	✓	1.3179

PLASTERBOARD CUTTER

DWR L20



No load speed	28.000	rpm
Insertion	1/4" - 1/8"	UNF
Weight	0.96	kg

						Code
DWR L20	X	X	X			1.3229
DWR L2012 Set	1 x 2.0Ah	✓	✓			1.3230
DWR L2022 Set	2 x 2.0Ah	✓	✓			1.3231

- **Cutting saw for drywall.**
- Ideal for **plasterboard, electrical cutouts in drywall walls and ceilings**
- **LED guide light.**
- **Adjustable depth to improve support and control of the cut, depending.**
- Suitable for fast and small plasterboard cuts, thanks to its 18,000 rpm.
- Sealed switch with dust protection.
- **Soft Start.**



- Quick cutter change.
- Lightweight and ergonomic for one-handed operation.
- **1/4" (6.4 mm) and 1/8" (3.2 mm) collets.**

- Burr 1/4 Cardboard - Fast cutting plaster DWR L20 **12.926**
- Burr 1/8 Cardboard - Clean cut plaster DWR L20 **12.927**

SILICON GUN 18V

CG L20

Max. feed power	5000	N
Feeding speed	0.7 / 11	mm/s
Max cartridge capacity	310	ml
Weight	2	kg

Code

CG L20	X	X	X	1.2760
CG L2012 Set	1 x 2.0Ah	✓	✓	1.2802
CG L2022 Set	2 x 2.0Ah	✓	✓	1.2803
CG L2014 Set	1 x 4.0Ah	✓	✓	1.2804
CG L2024 Set	2 x 4.0Ah	✓	✓	1.3162
CG L2025 Set	2 x 5.0Ah	✓	✓	1.3164



- Consistent and uniform silicone beads. The tool is specially designed to be adapted to the thickness, stickiness and viscosity of the cartridge used.
- Anti dripping system to avoid stains after stopping the tool.
- 6 levels electronic speed regulator.

- Safety switch lock.
- Power controlled by trigger pressure.
- Anti sliding ergonomic handle.
- Specially meant for long duration tasks with high thickness and viscosity materials.
- Designed for glass work, assemblies, automotive, tiling & work with all types of glass panels.

SAUSAGE CARTRIDGE

Code 1.3040

Dimensions	ø60 x 500	mm
Max. tube capacity	600	ml
Weight	780	gr

- Cartridge to expand the capacity of the CG L20 up to 600 ml.
- Specially designed for large capacity sausages of polyurethane, silicone and other adhesives.
- Easy installation on the tool by replacing the push rod and screwing the cartridge to the gun.



SILICONE GUN AND SAUSAGE CARTRIDGE

Code

CG L2012 + CARTRIDGE	1 x 2.0Ah	✓	✓	1.3167
CG L2022 + CARTRIDGE	2 x 2.0Ah	✓	✓	1.3168
CG L2014 + CARTRIDGE	1 x 4.0Ah	✓	✓	1.3169
CG L2024 + CARTRIDGE	2 x 4.0Ah	✓	✓	1.3170

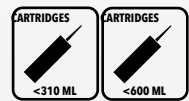

RIVETER GUN 18V

RG L20

RG 6.4 L20

RG 5.0 L20 RG 6.4 L20

Tensile strength	16000	22000	N
Rivet size	2.4 - 3.2 - 4.0 - 5.0	4.0 - 6.4	mm
Rivet length	25	28	mm
Riveting modes	Automa. / manual	Automa. / manual	
Weight	1.45	1.45	kg

NOZZLES RG 5.0 L20	1.4181
NOZZLES RG 6.4 L20	1.4182

Code

RG 5.0 L20 BRUSHLESS	X	X	X	1.3347
RG 5.0 L2022 BRUSHLESS	2 x 2.0Ah	✓	✓	1.3348
RG 5.0 L2024 BRUSHLESS	2 x 4.0Ah	✓	✓	1.3349
RG 5.0 L2025 BRUSHLESS	2 x 5.0Ah	✓	✓	1.3350

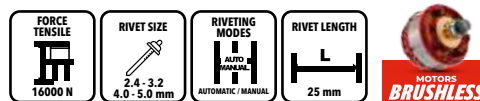

- **BRUSHLESS motor** (increased performance and service life).
- **STAYER Li-ion HIGH-TECH, L20 battery** with overcharge, battery discharge, overheating and short circuit protection. LED charge indicator.
- **Blind rivets 27 mm long.**
- Ergonomic and balanced handle.
- Rivet material: **Aluminum, Stainless steel, Steel.**
- LED guide light.



Code

RG 6.4 L20 BRUSHLESS	X	X	X	1.3386
RG 6.4 L2022 BRUSHLESS	2 x 2.0Ah	✓	X	1.3400
RG 6.4 L2024 BRUSHLESS	2 x 4.0Ah	✓	X	1.3401
RG 6.4 L2025 BRUSHLESS	2 x 5.0Ah	✓	X	1.3402

NIBBLER

NP L20

Speed	0 - 1600	rpm
Max. thickness steel	1.2	mm
Max. thickness iron	1.6	mm
Max. thickness Aluminum	2.5	mm
Weight	2.1	kg

				Code
NP L20	X	X	X	1.3868
NP L2012	1 x 2.0Ah	✓	✓	1.3961
NP L2022	2 x 2.0Ah	✓	✓	1.3962
NP L2014	1 x 4.0Ah	✓	✓	1.3964
NP L2024	2 x 4.0Ah	✓	✓	1.3965



MOTORS BRUSHLESS
NEW
Check Availability

 NO LOAD SPEED 0-1600 rpm	 WEIGHT 2.1 kg	 PADDLE SWITCH INTERRUPTOR PALA	 NO SPARKS
---------------------------------	----------------------	---------------------------------------	---------------



- Tool Holder NP L20 Code **12.1057**
- Blade NP L20 Code **12.1056**

DIE GRINDER

SD 27 L20

Power	600	W
No load speed	10000 - 26000	rpm
Collet	6 / 6.3 / 8	mm
Weight	1.4	kg

				Code
SD 27 L20	X	X	X	1.3867
SD 27 L2014	1 x 4.0Ah	✓	✓	1.3966
SD 27 L2024	2 x 4.0Ah	✓	✓	1.3931
SD 27 L2025	2 x 5.0Ah	✓	✓	1.3968
SD 27 L2026	2 x 6.0Ah	✓	✓	1.3969



NEW
Check Availability

 NO LOAD SPEED 10000 - 26000 rpm	 INSERTION 6 / 6.3 / 8 mm	 WEIGHT 1.4 kg	 PADDLE SWITCH INTERRUPTOR PALA	 SOFT START	 SPEED CONSTANT
--	---------------------------------	----------------------	---------------------------------------	-------------------	-----------------------



Soft Grip

MOTORS BRUSHLESS

RATCHET WRENCH 18V - 3/8" y 1/4"

RW L20

No load speed	0-250	rpm
Insertion	ø3/8	"
Tightening Torque	60	Nm
Weight	1	kg

				Code
RW L20	X	X	X	1.3082
RW L2012 Set	1 x 2.0Ah	✓	✓	1.3267
RW L2022 Set	2 x 2.0Ah	✓	✓	1.3268
RW L2014 Set	1 x 4.0Ah	✓	✓	1.3269
RW L2024 Set	2 x 4.0Ah	✓	✓	1.3270



 NO LOAD SPEED 0-250 min ⁻¹	 MAX TORQUE 60 Nm	 INSERTION 3/8" - 1/4"	 WEIGHT 1.1 kg
--	-------------------------	------------------------------	----------------------

- Ideal for mechanical and/or automotive tightening work.
- **Adapter for 1/4" wrench.**
- Locking lever.
- **Easy access to spaces.**
- Adjustable trigger for easy tool handling.
- **LED guide light.**
- Rubber coating for better adherence.
- **L20 battery insertion.**
- **Variable speed.**
- Adapter 3/8"

RATCHET WRENCH 18V - 1/2"

RWB 100 L20

No load speed	0 - 150 / 0 - 190 / 0 - 250	rpm
Insertion	ø3/8 - 1/2	"
Tightening Torque	100	Nm
Weight	1.3	kg

				Code
RWB 100 L20	X	X	X	1.3729
RWB 100 L2012	1 x 2.0Ah	✓	✓	1.3920
RWB 100 L2022	2 x 2.0Ah	✓	✓	1.3921
RWB 100 L2014	1 x 4.0Ah	✓	✓	1.3922
RWB 100 L2024	2 x 4.0Ah	✓	✓	1.3923



Adapter 3/8"

 NO LOAD SPEED 0 - 600 rpm	 MAX TORQUE 100 Nm	 INSERTION 1/2"	 WEIGHT 1.3 kg
----------------------------------	--------------------------	-----------------------	----------------------



MOTORS BRUSHLESS

- Ideal for mechanical and/or automotive tightening work.
- **Adapter for 3/8" wrench.**
- Locking lever.
- **Easy access to spaces.**
- Adjustable trigger for easy tool handling.
- **LED guide light.**
- Rubber coating for better adherence.
- **L20 battery insertion.**
- **Variable speed.**

BRUSHLESS IMPACT WRENCH 18V - 1/2"

IWB 350 B L20

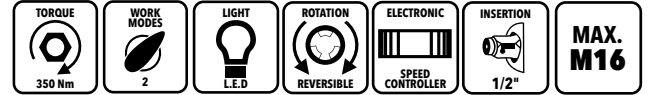

NEW

No load speed	0-1000 / 0-1600 / 0-2200 / 0-2800	rpm
Impacts	0-1900 / 0-2800 / 0-3400 / 0-3900	ipm
Insertion	150 / 250 / 350 / 420	Nm
Tightening Torque	1/2"	UNF
Torque of disassembly	550	Nm
Weight	1.1	kg

Code

IWB 350 B L20	X	X	X	1.4456
IWB 350 B L2012	1 x 2.0Ah	✓	✓	1.4574
IWB 350 B L2014	1 x 4.0Ah	✓	✓	1.4576
IWB 350 B L2022	2 x 2.0Ah	✓	✓	1.4575
IWB 350 B L2024	2 x 4.0Ah	✓	✓	1.4577
IWB 350 B L2025	2 x 5.0Ah	✓	✓	1.4578

- **BRUSHLESS motor** (increased performance and service life) .
- 4 Adjustments combining speed, impacts and torque.
- **Max. loosening torque: 420 Nm**
- **Powerful brushless motor**
- **STAYER Li-ion HIGH-TECH, L20 battery. LED charge indicator.**
- Safety clutch and brake
- Reversible.
- Speed regulator.
- Anti-vibration rubber coating
- L.E.D guide light..



Applications:

- Light vehicle maintenance
- Assembly of small metal structures
- DIY tasks



BRUSHLESS IMPACT WRENCH 18V - 1/2"

IWB 550 L20

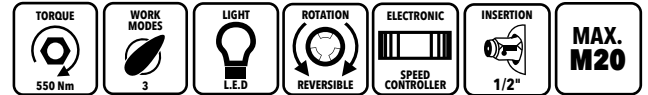

No load speed	0-1800 / 0-2300 / 0-2800	rpm
Impacts	0-1800 / 0-2200 / 0-3000	ipm
Insertion	300 - 450 - 550	Nm
Tightening Torque	1/2"	UNF
Weight	1.50	kg

Code

IWB 550 L20	X	X	X	1.4377
IWB 550 L2012	1 x 2.0Ah	✓	✓	1.2971
IWB 550 L2014	1 x 4.0Ah	✓	✓	1.2973
IWB 550 L2022	2 x 2.0Ah	✓	✓	1.2972
IWB 550 L2024	2 x 4.0Ah	✓	✓	1.2974
IWB 550 L2025	2 x 5.0Ah	✓	✓	1.2975

- **BRUSHLESS motor** (increased performance and service life) .
- 3 working levels, with different degrees of torque, speed and impacts.
- **2 loosening modes:**
- **Spot - Max. torque Continuous**
- **Max. loosening torque: 750 Nm**
- **Powerful brushless motor**
- **STAYER Li-ion HIGH-TECH, L20 battery. LED charge indicator.**
- Safety clutch and brake
- Reversible.
- Speed regulator.
- Anti-vibration rubber coating
- L.E.D guide light..



Applications:

- Repair of vehicles.
- Machinery installation.
- Scaffolding erection..



BRUSHLESS IMPACT WRENCH 18V - 1/2"

IWB 750 L20

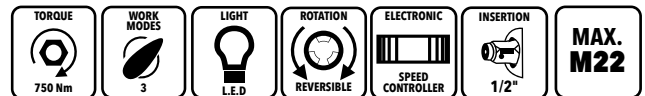

No load speed	0-1400 / 0-1900 / 0-2400	rpm
Impacts	0-1600 / 0-2000 / 0-2400	ipm
Insertion	300 / 500 / 750	Nm
Tightening Torque	1/2"	UNF
Weight	2	kg

Code

IWB 750 L20	X	X	X	1.4455
IWB 750 L2014	1 x 4.0Ah	✓	✓	1.2978
IWB 750 L2022	2 x 2.0Ah	✓	✓	1.2977
IWB 750 L2024	2 x 4.0Ah	✓	✓	1.2979
IWB 750 L2025	2 x 5.0Ah	✓	✓	1.2980
IWB 750 L2026	2 x 6.0Ah	✓	✓	1.3272

- **BRUSHLESS motor** (increased performance and service life) .
- 3 working levels, with different levels of torque, speed and impacts:
- 0- 1400 rpm / 300 Nm / 0 - 1600 ipm.
- 0- 1900 rpm / 500 Nm / 0 - 2000 ipm.
- 0- 2400 rpm / 750 Nm / 0 - 2400 ipm.
- **2 loosening modes:**
- **Spot - Max. torque Continuous**
- **Max. loosening torque: 1000 Nm**
- **Powerful brushless motor.**
- **STAYER Li-ion HIGH-TECH, L20 battery. LED charge indicator.**
- Safety clutch and brake
- Reversible.
- Speed regulator.
- Anti-vibration rubber coating
- L.E.D guide light..



Applications:

- Maintenance of light trucks.
- Agricultural machinery.
- Construction works.



BRUSHLESS IMPACT WRENCH 18V - 1/2"

IWB 900 L20

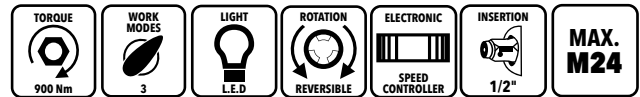

No load speed	0-1100 / 0 - 1500 / 0 - 1850	rpm
Impacts	0-1300 / 0 - 1800 / 0 - 2300	ipm
Insertion	650 / 850 / 900	Nm
Tightening Torque	1/2"	UNF
Weight	2.3	kg



Applications:
 -Maintenance of commercial vehicles.
 -Construction equipment.
 -Industrial applications.



				Code
IWB 900 L20	X	X	X	1.4378
IWB 900 L2024	2 x 4.0Ah	✓	✓	1.4579
IWB 900 L2025	2 x 5.0Ah	✓	✓	1.4580
IWB 900 L2026	2 x 6.0Ah	✓	✓	1.4581

- **BRUSHLESS motor** (increased performance and service life).

- 3 working levels, with different levels of torque, speed and impacts:

0 - 1100 rpm / 650 Nm / 0 - 1300 ipm.

0 - 1500 rpm / 850 Nm / 0 - 1800 ipm.

0 - 1850 rpm / 900 Nm / 0 - 2300 ipm.

- **2 loosening modes:**

Spot - Max. torque Continuous

- **Max. loosening torque: 1300 Nm**

- **Powerful brushless motor.**

- **STAYER Li-ion HIGH-TECH, L20 battery.**

LED charge indicator.

- Safety clutch and brake

- Reversible.

- Speed regulator.

- Anti-vibration rubber coating

- L.E.D guide light..

NEW
Check Availability

BRUSHLESS IMPACT WRENCH 18V - 1/2"

IWB 1000 L20

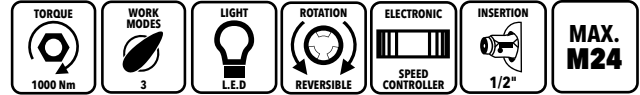

No load speed	0-1000 / 0-1200 / 0-1700	rpm
Impacts	0-1200 / 1-1500 / 0-2100	ipm
Insertion	650 / 850 / 1000	Nm
Tightening Torque	1/2"	UNF
Weight	3.2	kg



Applications:
 -Maintenance of commercial vehicles.
 -Construction equipment.
 -Industrial applications.



				Code
IWB 1000 L20	X	X	✓	1.2791
IWB 1000 L2024	2 x 4.0Ah	✓	✓	1.2586
IWB 1000 L2025	2 x 5.0Ah	✓	✓	1.2995
IWB 1000 L2026	2 x 6.0Ah	✓	✓	1.3276

- **BRUSHLESS motor** (increased performance and service life).

- 3 working levels, with different levels of torque, speed and impacts:

0 - 1000 rpm / 650 Nm / 0 - 1200 ipm.

0 - 1200 rpm / 800 Nm / 0 - 1500 ipm.

0 - 1700 rpm / 1000 Nm / 0 - 2100 ipm.

- **2 loosening modes:**

Spot - Max. torque Continuous

- **Max. loosening torque: 1300 Nm**

- **Powerful brushless motor.**

- **STAYER Li-ion HIGH-TECH, L20 battery.**

LED charge indicator.

- Safety clutch and brake

- Reversible.

- Speed regulator.

- Anti-vibration rubber coating

- L.E.D guide light..

BRUSHLESS IMPACT WRENCH 18V - 3/4"

IWB 1600 L2027

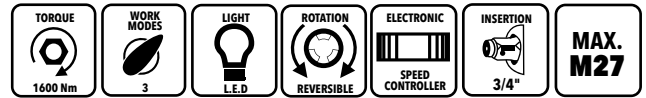

No load speed	0 - 1000 / 0 - 1400 / 0 - 1700	rpm
Impacts	1000 / 1800 / 2400	ipm
Insertion	900 / 1300 / 1600	Nm
Tightening Torque	2100	Nm
Par de desapriete	3/4"	UNF
Weight	3.4	kg

Applications:
 -Maintenance of heavy machinery.
 -Agriculture.
 -Mining equipment.
 -Large metallic structures.



			Code
IWB 1600 L2027	2 x 7.5Ah	✓	✓ 1.3794



- **BRUSHLESS motor** (increased performance and service life).

- 3 working levels, with different levels of torque, speed and impacts:

0 - 1000 rpm / 900 Nm / 0 - 1000 ipm.

0 - 1400 rpm / 1300 Nm / 0 - 1800 ipm.

0 - 1700 rpm / 1600 Nm / 0 - 2400 ipm.

- 2 loosening modes:

Spot - Max. torque Continuous

- **Max. loosening torque: 2100 Nm**

- **Powerful brushless motor.**

- **STAYER Li-ion HIGH-TECH, L20 battery.**

LED charge indicator.

- Safety clutch and brake

- Reversible.

- Speed regulator.

- Anti-vibration rubber coating

- L.E.D guide light..

BRUSHLESS IMPACT WRENCH 18V - 1"

IWB 1800 L20

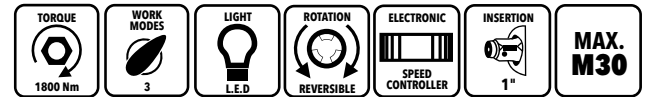

No load speed	0 - 1000 / 0 - 1400 / 0 - 1700	rpm
Impacts	1000 / 1800 / 2400	ipm
Insertion	900 / 1300 / 1800	Nm
Tightening Torque	2500	Nm
Par de desapriete	1"	UNF
Weight	3.6	kg

Applications:
 -Maintenance of heavy machinery.
 -Agriculture.
 -Mining equipment.
 -Large metallic structures.



			Code
IWB 1800 L2027	2 x 7.5Ah	✓	✓ 1.3845
IWB 1800 L2028	2 x 8.0Ah	✓	✓

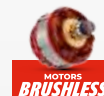

- **BRUSHLESS motor** (increased performance and service life).

- 3 working levels, with different levels of torque, speed and impacts:

0 - 1000 rpm / 900 Nm / 0 - 1000 ipm.

0 - 1400 rpm / 1300 Nm / 0 - 1800 ipm.

0 - 1700 rpm / 1800 Nm / 0 - 2400 ipm.

- 2 loosening modes:

Spot - Max. torque Continuous

- **Max. loosening torque: 2500 Nm**

- **Powerful brushless motor.**

- **STAYER Li-ion HIGH-TECH, L20 battery.**

LED charge indicator.

- Safety clutch and brake

- Reversible.

- Speed regulator.

- Anti-vibration rubber coating

- L.E.D guide light..

ORBITAL SANDER 18V

LOM L20

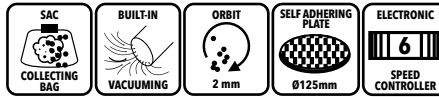

Plate size		125	mm
No load speed	2000 / 3500 / 5000 / 6500 / 8000 / 10000		rpm
Orbit		2.7	mm
Weight		1.1	kg

- Self adhering plate with 8 holes
- Built-in dust collection tank
- 6 levels electronic speed regulator
- Ergonomic design for single hand use

- Included
Dust collecting bag
x2 Sanding sheets
P120 & P400



	X	X	X	Code
LOM L20	X	X	X	1.2069
LOM L2012 Set	1 x 2.0Ah	✓	✓	1.2536
LOM L2022 Set	2 x 2.0Ah	✓	✓	1.2213

SANDER 18V

DELTA L20

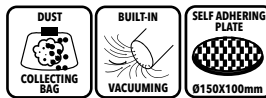

No load speed		11000	rpm
Plate		148x100	mm
Sandpaper		150x150x100	mm
Orbit		1.6	mm
Weight		0.85	kg

- Adhesive plate with 15 suction holes.
- Built-in dust collection tank
- Ergonomic design for one-handed operation.

- Included
3 sheets of sandpaper.



	X	X	X	Code
DELTA L20	X	X	X	1.3302
DELTA L2012 Set	1 x 2.0Ah	✓	✓	1.3303
DELTA L2022 Set	2 x 2.0Ah	✓	✓	1.3304

MILLING MACHINE 18V

PR8 L20



No load speed		10000-30000	rpm
Plate size		ø125	mm
Clamp		6 - 8	mm
Weight		1.1	kg

- **BRUSHLESS motor** (increased performance and service life.)
- Effortless milling of wood edges, grooves and decorative motifs
- Suction adapter for a clean working environment.
- **Powerful brushless motor** for increased efficiency, significantly reducing heating and significantly increasing motor life and battery life.

- **STAYER Li-ion HIGH-TECH, L20** battery with protection against overcharge, battery discharge, overheating, short circuit. **LED charge indicator.**
- Light and comfortable to use thanks to its compact design and low weight of only 1.1 kg.

**Adapter for
PR8 COMPACT L20
12.973**



PR8 COMPACT L20 **Code**

	X	X	X	Code
PR8 COMPACT L20	X	X	X	1.3246
PR8 COMPACT L20 2012	1 x 2.0Ah	✓	✓	1.3247
PR8 COMPACT L20 2022	2 x 2.0Ah	✓	✓	1.3248
PR8 COMPACT L20 2014	1 x 4.0Ah	✓	✓	1.3249
PR8 COMPACT L20 2024	2 x 4.0Ah	✓	✓	1.3250

PR8 PRO L20 **Code**

	X	X	✓	Code
PR8 PRO L20	X	X	✓	1.3351
PR8 PRO L20 2012	1 x 2.0Ah	✓	✓	1.3252
PR8 PRO L20 2022	2 x 2.0Ah	✓	✓	1.3253
PR8 PRO L20 2014	1 x 4.0Ah	✓	✓	1.3254
PR8 PRO L20 2024	2 x 4.0Ah	✓	✓	1.3255

RECIPROCATING SAW 18V

SS L20



Saws per minute	0-3000	spm
Saw displacement	22	mm
Max. wood cutting	180	mm
Max. metal profile cutting	100	mm
Max. solid steel cutting	10	mm
Max. aluminum cutting	25	mm
Weight	1.7	kg



SS L20	X	X	X	1.2080
SS L2012 Set	1 x 2.0Ah	✓	✓	1.2531
SS L2014 Set	1 x 4.0Ah	✓	✓	1.2532
SS L2022 Set	2 x 2.0Ah	✓	✓	1.2210



- Pendular cut setting
- Quick blade change. Universal insertion
- Cutting depth regulator
- Speed controller trigger
- Safety switch lock
- L.E.D guide light.

RECIPROCATING SAW 18V

SSP L20



Saws per minute	0-3100	spm
Saw displacement	28	mm
Max. wood cutting	210	mm
Max. metal profile cutting	110	mm
Max. solid steel cutting	15	mm
Max. aluminum cutting	30	mm
Weight	2.7	kg



SSP L20	X	X	X	1.2892
SSP L2014 Set	1 x 4.0Ah	✓	✓	1.3003
SSP L2022 Set	2 x 2.0Ah	✓	✓	1.3002
SSP L2024 Set	2 x 4.0Ah	✓	✓	1.3004
SSP L2025 Set	2 x 5.0Ah	✓	✓	1.3005



- Pendular cut setting
- Quick blade change. Universal insertion
- Cutting depth regulator
- Speed controller trigger
- Safety switch lock
- L.E.D guide light.

RECIPROCATING SAW 18V

SS LITE L20

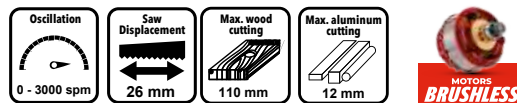

Saws per minute	0-3000	spm
Saw displacement	26	mm
Max. wood cutting	110	mm
Max. metal profile cutting	8	mm
Max. aluminum cutting	12	mm
Weight	1.66	Kg



SS LITE L20	X	X	X	1.4178
SS LITE L2022	1 x 2.0Ah	✓	✓	1.4423
SS LITE L2024	2 x 4.0Ah	✓	✓	1.4424

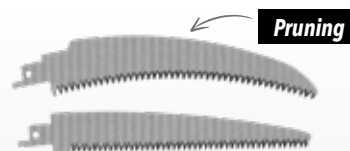

- Includes:**
- 1 Curved saw blade.
 - 1 Straight saw blade..



ULTRA LIGHT

NEW

- 18V battery powered reciprocating saw with a powerful BRUSHLESS motor.
- Quick blade change system with universal insertion.
- To cut all types of materials such as wood / pruning / logs / pallet repair / cutting metal profiles and sheets / PVC pipes.
- With variable speed.
- With safety switch lock.
- Great cutting capacity.
- STAYER Li-ion HIGH-TECH, L20 battery with overcharge, battery discharge, overheating and short circuit protection. LED charge indicator

JIG SAW 18V

S L20



Blowing Function

No load speed	0-2700	rpm
Saw displacement	20	mm
Max. wood cutting	90	mm
Max. steel cutting	8	mm
Max. aluminum cutting	12	mm
Tilted cut	0-45	°
Weight	1.7	kg

- Pendular cutting 4 settings
- Quick blade change. T insertion
- Aluminum base
- Speed regulator on the trigger
- Safety switch lock
- L.E.D guide light.
- Built-in blower
- Ready for coupling with an external vacuum cleaner



Code

S L20	X	X	X	1.2136
S L2012 Set	1 x 2.0Ah	✓	✓	1.2535
S L2022 Set	2 x 2.0Ah	✓	✓	1.2211
S L2024 Set	2 x 4.0Ah	✓	✓	1.2217

JIG SAW 18V

SB L20 BRUSHLESS



Metal Structure

No load speed	0 - 3400	rpm
Saw displacement	25.4	mm
Max. wood cutting	135	mm
Max. steel cutting	10	mm
Max. aluminum cutting	20	mm
Tilted cut	0 - 45	°
Weight	1.75	kg

- Pendular cutting 4 settings
- Quick blade change. T insertion
- Aluminum base
- Speed regulator on the trigger
- Safety switch lock
- L.E.D guide light.
- Ready for coupling with an external vacuum cleaner



Code

SB L20	X	X	X	1.3875
SB L2022 Set	2 x 2.0Ah	✓	✓	1.3996
SB L2024 Set	2 x 4.0Ah	✓	✓	1.3997
SB L2025 Set	2 x 5.0Ah	✓	✓	1.3999

NAILER STAPPLER 18V

NS L20

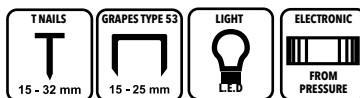

Impacts per minute	30	ipm
T nails	15-32	mm
Staples	15-25	mm
Weight	1.8	kg

- Suitable for "T" Nails from ø15 to 32 mm & staples from 15 to 25 mm., Type 53.
- Specially designed for upholstery and wood working
- Pressure regulator
- Precision head with security sensor
- L.E.D guide light.



Code

NS L20	X	X	1.2642
NS L2012	1 x 2.0Ah	✓	1.2643
NS L2022	2 x 2.0Ah	Bolsa	1.2846

Accessories

Code

Nails Box	Length 15mm	1000 pcs	12.889
Nails Box	Length 32mm	1000 pcs	12.890
Staples Box	Depth 15mm	1000 pcs	12.891

RAPTOR X L20

MINI CIRCULAR SAW 18V



BRUSHLESS

L20 RANGE
LHON STAYER

18V battery powered Mini Cutter with a powerful BRUSHLESS motor ensuring high torque and great durability.

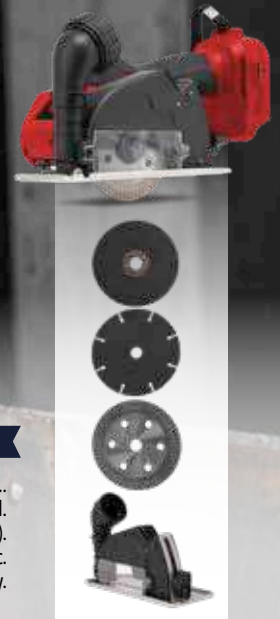

NEW

Check Availability

Code

No load speed	0-20000	rpm
Disc diameter	Ø76	mm
Disc axis	Ø10	mm
Weight	0.81	Kg

Raptor X L20	X	X	X	1.4448
Raptor X L2022	1 x 2.0Ah	✓	✓	1.4531
Raptor X L2022	2 x 2.0Ah	✓	✓	1.4532
Raptor X L2024	2 x 4.0Ah	✓	✓	1.4533

- 1 quick-release skid plate..
- 3 abrasive discs for metal.
- 1 multi-material disc (tungsten carbide).
- 1 extra-thin Turbo diamond disc.
- 1 Allen key.

CIRCULAR SAW 18V

CP L20

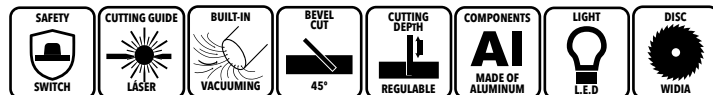

Disc diameter	165 x 20	mm
No load speed	4200	rpm
Max 90° cutting capacity	54	mm
Max 45° cutting capacity	35	mm
Weight	3.2	kg

Code

CP L20	X	X	X	1.2232
CP L2012 Set	1 x 2.0Ah	✓	✓	1.2533
CP L2014 Set	1 x 4.0Ah	✓	✓	1.2534
CP L2022 Set	2 x 2.0Ah	✓	✓	1.2236

- **Powerful motor 785**
- **Laser cutting guide**
- Aluminum base
- Cutting depth regulator
- Safety switch lock
- Ready for coupling with an external vacuum cleaner
- Speed regulator.

- **Included**
Lateral guide



CIRCULAR SAW 18V

CP 165 G L20

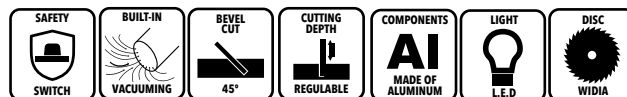

Disc diameter	165 x 20	mm
No load speed	5200	rpm
Max 90° cutting capacity	55	mm
Max 45° cutting capacity	41	mm
Weight	3.6	kg

Code

CP 165 G L20	X	X	X	1.3866
CP 165 G L2012	1 x 2.0Ah	✓	✓	1.4067
CP 165 G L2022	1 x 2.0Ah	✓	✓	1.4071
CP 165 G L2024	2 x 4.0Ah	✓	✓	1.4070

- **Powerful motor 785**
- **Laser cutting guide**
- Aluminum base
- Cutting depth regulator
- Safety switch lock
- Ready for coupling with an external vacuum cleaner
- Speed regulator.

- **Included**
Lateral guide



MULTI TOOL BRUSHLESS L20

OSCILLATING MULTI TOOL



BRUSHLESS

L20 RANGE
Li-ION **STAYER**

Advanced anti-vibration structure providing a comfortable and pleasant soft-touch working experience, reducing fatigue.



QUICK TOOL CHANGE

6-SPEED ELECTRONIC VARIATOR

SILENT AND VIBRATION-FREE

CONSTANT POWER

OSCILLATING MULTI TOOL 18V

MULTI TOOL BRUSHLESS L20

Power	18	V
No load speed	8000-16000	rpm
Orbit	4	°
Weight	1.12	Kg

Code

MULTI TOOL BRUSHLESS L20	X	X	1.4167
MULTI TOOL BRUSHLESS L2022	2 x 2.0Ah	✓	1.4418
MULTI TOOL BRUSHLESS L2024	2 x 4.0Ah	✓	1.4419

- Oscillating multi-tool with a powerful BRUSHLESS motor, designed for the toughest jobs.
- Advanced anti-vibration structure offering a comfortable and pleasant soft-touch working experience, reducing fatigue.
- Quick tool change.
- 4° oscillation angle.
- Robust and ergonomic design.
- Great versatility for a multitude of applications: sanding, paint scraping, wood and plastic sawing as well as cutting tiles and PVC pipes.
- Dust extraction kit included.
- STAYER Li-ion HIGH-TECH, L20 battery with overcharge, battery discharge, overheating and short circuit protection.
- LED charge indicator.
- Operates silently and without vibration

NEW

[Check Availability](#)



ACCESSORY SET

- 1 HCS straight wood cutting blade.
- 1 65 Mn scraper blade.
- 1 delta plate for sanding.
- 3 sanding sheets.
- 1 dust extraction kit.
- 1 instruction manual.

BRANCH PRUNER 18V
BPB 32 L20 BRUSHLESS



Max cutting diameter	ø32	mm
Cuts per second	1 - 1.4	Cortes
Weight	0.95	kg



	X	X	X	Code
BPB 32 L20	X	X	X	1.2759
BPB 32 L2012 Set	1 x 2.0Ah	✓	✓	1.2805
BPB 32 L2014 Set	1 x 4.0Ah	✓	✓	1.2807
BPB 32 L2022 Set	2 x 2.0Ah	✓	✓	1.2806
BPB 32 L2024 Set	2 x 4.0Ah	✓	✓	1.2808

- **BRUSHLESS motor** (increased performance and service life).
- **Automatic branch pruner** specially designed for gardening, agriculture, pruning vineyards and fruit trees.
- **Double safety system.**
- **STAYER Li-ion HIGH-TECH, L20 battery.**
- **LED charge indicator.**
- On/Off switch.
- Trigger with safety lock
- Automatic safety lock.
- Ergonomic non-slip handle.
- Particularly suitable for long-lasting tasks.
- **Japanese 5K5 steel, extremely sharp and durable.**
- **Ideal for intensive pruning.**



MINI CHAIN SAW 18V
MINI OLMO L20 (Automatic refrigeration)

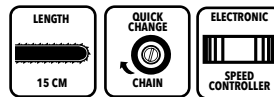

No load speed	0-4400	rpm
Cutting speed	7.8	m/s
Chain length	ø160	mm
Cutting speed	196	mm
Weight	1.5	Kg



	X	X	X	Code
MINI OLMO L20	X	X	X	1.2794
MINI OLMO L2012 Set	1 x 2.0Ah	✓	✓	1.2809
MINI OLMO L2014 Set	1 x 4.0Ah	✓	✓	1.2811
MINI OLMO L2022 Set	2 x 2.0Ah	✓	✓	1.2810
MINI OLMO L2024 Set	2 x 4.0Ah	✓	✓	1.2812
MINI OLMO L2015 Set	1 x 5.0Ah	✓	✓	1.3305

- **Mini chain saw** specially designed for gardening, agriculture, vine yard and fruit tree pruning.
- **Specially designed to be used with one hand.**
- Power controlled by trigger pressure.
- Safety switch lock.
- Anti sliding ergonomic handle.
- Specially meant for long duration tasks.

- **Included**
Lubricant
x2 Service keys



MINI CHAIN SAW 18V
MINI OLMO B L20 (Manual cooling)

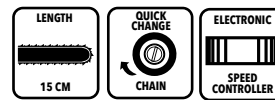

No load speed	0-4400	rpm
Cutting speed	7.8	m/s
Chain length	ø160	mm
Cutting speed	196	mm
Weight	1.5	Kg



	X	X	X	Code
MINI OLMO BL20	X	X	X	1.2991
MINI OLMO B L2012 Set	1 x 2.0Ah	✓	✓	1.3010
MINI OLMO B L2014 Set	1 x 4.0Ah	✓	✓	1.3011
MINI OLMO B L2022 Set	2 x 2.0Ah	✓	✓	1.3012
MINI OLMO B L2024 Set	2 x 4.0Ah	✓	✓	1.3013
MINI OLMO B L2015 Set	1 x 5.0Ah	✓	✓	1.3306

SPECIAL CHAIN FOR FASTER CUTTING

Lubrication tank



Tilting head 32°



Manual pump

- **BRUSHLESS motor** (increased performance and service life).
- **Mini 18V battery-powered saw** with maximum cutting capacity of 100 mm and 150 mm blade length.
- Specially designed for professional work in vineyards, fruit plantations as well as gardening, horticulture and agriculture.
- Quick chain change system.
- Trigger with pressure-controlled speed regulator.



BRANCH PRUNER 18V

BPB 40 AGRO L20 BRUSHLESS

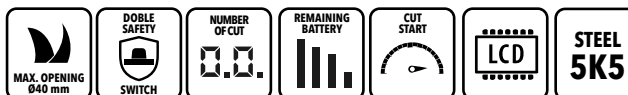

Max cutting diameter	ø40	mm
Cuts per second	1 - 2	Cortes
Weight	0.95	kg



				Code
BPB 40 L20	X	X	X	1.2992
BPB 40 L2012 Set	1 x 2.0Ah	✓	✓	1.3006
BPB 40 L2014 Set	1 x 4.0Ah	✓	✓	1.3007
BPB 40 L2022 Set	2 x 2.0Ah	✓	✓	1.3008
BPB 40 L2024 Set	2 x 4.0Ah	✓	✓	1.3009

- Greater control in delicate cuts.
- More demanding and precise pruning in horticulture and professional gardening.
- Large fruit trees or intensive pruning.
- 2 settings 30 and 40 mm.
- Progressive cutting.
- **BRUSHLESS motor** (increased performance and service life).
- Number of cuts counter.

- Battery auto memory.
- Automatic branch pruner specially designed for gardening, agriculture, vineyard and fruit tree pruning.
- Double safety system
- STAYER Li-ion HIGH-TECH, L20 battery.
- LED charge indicator.
- On/off switch.
- Trigger with safety lock
- Automatic safety lock.
- Ergonomic non-slip handle.
- Particularly suitable for long-lasting tasks.
- **5K5 steel, extremely sharp and durable.**
- Ideal for intensive pruning.**

MINI CHAIN SAW 18V

MINI OLMO C L20

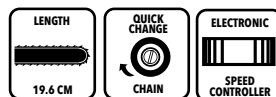

NEW

No load speed	0-4400	rpm
Cutting speed	7.8	m/s
Chain length	ø160	mm
Cutting speed	196	mm
Weight	1.5	kg



				Code
MINI OLMO C L20	X	X	X	1.4328
MINI OLMO C L2024	1 x 4.0Ah	✓	✓	1.4416
MINI OLMO C L2025	1 x 5.0Ah	✓	✓	1.4417

Self-lubrication

TELESCOPIC PRUNING POLE

Code 12.940



NEW

Material	Steel HCS	
Extension Length	1.5 - 1.9	m
Weight	1,75 kg / 3,86 lb	



- Telescopic pruning pole that allows attaching the **Mini Olmo C** mini chain saws and the **BPB 40** battery powered branch pruners from the **STAYER L20 SERIES**.

CHAIN SAW 18V

OLMO 250 L20

No load speed	0 - 3800	rpm
Guide bar	250	mm
Cutting speed	6	m/s
Weight	2.9	kg

Code

OLMO 250 L20	X	X	X	1.3239
OLMO 250 L2014 Set	1 x 4.0Ah	✓	X	1.3240
OLMO 250 L2024 Set	2 x 4.0Ah	✓	X	1.3241
OLMO 250 L2015 Set	1 x 5.0Ah	✓	X	1.3242
OLMO 250 L2025 Set	2 x 5.0Ah	✓	X	1.3243
OLMO 250 L2026 Set	2 x 6.0Ah	✓	X	1.3245

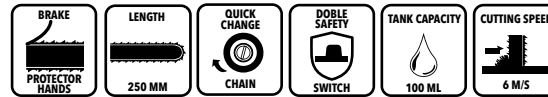

- Saw specially designed for gardening, agriculture.
- Adjustable speed by trigger.
- Trigger with safety lock.



HEDGE TRIMMER 18V

ROSE L20

No load speed	1300	spm
Teeth spacing	15	mm
Guide bar	510	mm
Rotary handle	0-45-90	°
Weight	2.25	kg

Code

ROSE L20	X	X	X	1.2137
ROSE L2012 Set	1 x 2.0Ah	✓	X	1.2538
ROSE L2022 Set	2 x 2.0Ah	✓	X	1.2238
ROSE L2024 Set	2 x 4.0Ah	✓	X	1.3307

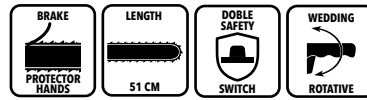

- Double sawing blade.
- Double safety switch
- Hand shield
- 5 positions rotary handle.

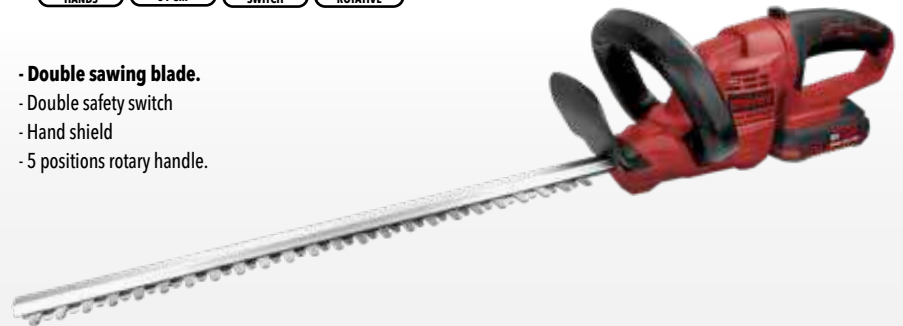

GRASS CUTTER 18V

GRASS CUTTER L20

Cutting diameter	ø280	mm
Wire thickness	ø1.6	mm
Roll length	3	m
Weight	2	kg

Code

GRASS CUTTER L20	X	X	X	1.2761
GRASS C L2022 Set	2 x 2.0Ah	✓	✓	1.2815
GRASS C L2024 Set	2 x 4.0Ah	✓	✓	1.2816

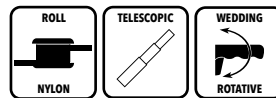

- Telescopic grass-cutter
- Aluminum structure.
- Double safety switch with power controller.
- Automatic thread feeding system.
- 180° rotary handle.
- Telescopic height (1 - 1.36m).



TELESCOPIC HEDGE TRIMMER / PRUNER 18V

MULTI GARDEN CUTTER L20

CHAIN SAW

Cutting speed	8	m/s
Tooth spacing	3/8"	
Guide bar	20	cm
Max. Cutting capacity	20	cm
Weight	2.1	kg

HEDGE TRIMMER

No load speed	1300	spm
Guide bar	43	cm
Weight	1.8	kg

Code

MGC L20	X	X	X	1.2795
MGC L2022 Set	2 x 2.0Ah	✓	✓	1.2813
MGC L2024 Set	2 x 4.0Ah	✓	✓	1.2814

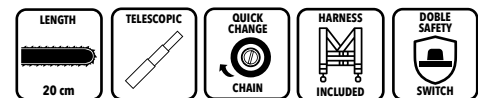

- Telescopic pruner with chainsaw and hedge trimmer functions.
- Easily interchangeable heads for smooth, uninterrupted work.
- Ergonomic non-slip handles for long work.



BLOWER 18V

VENTO XR L20



No load speed, turbine	23000	/min
Air speed	I 129.6 - II 162 - III 190	Km/h
Noise level	96	dB-w(A)
Air flow rate	I 384 - II 501 - III 604.8	m³/h
Weight	1.75	Kg



Code

VENTO XR L20	X	X	X	1.4166
VENTO XR L2012	1x 2.0Ah	✓	X	1.4449
VENTO XR L2022	2x 2.0Ah	✓	X	1.4450
VENTO XR L2024	2x 4.0Ah	✓	X	1.4451
VENTO XR L2025	2x 5.0Ah	✓	X	1.4602

- **18V battery powered blower**, max. air speed of **190 Km/h** with a large air flow rate of **604.8 m³/h**.

- **Lightweight and comfortable**, thanks to its balanced weight and ergonomic anti-sliding handle for easy one-handed operation.

- **Double switch** to prevent unintentional operation.

- **Specially suited for outdoor cleaning**, capable of quickly moving large amounts of leaves, debris, and dust.

NEW



SPRAYER 18V

SP L20



BATTERY HOUSING

Max. working pressure	4	Bar
Flow	> 0.8	L/min
Tank capacity	15	L
Spear length	800	mm
Weight	4.6	kg



Code

SP L20	X	X	X	1.2762
SP L2014 Set	1 x 4.0Ah	✓	X	1.2820
SP L2015 Set	1 x 5.0Ah	✓	X	1.2819
SP L2022 Set	2 x 2.0Ah	✓	X	1.2817
SP L2024 Set	2 x 4.0Ah	✓	X	1.2818

- **Sprayer for low viscosity liquids**, specially designed for **gardening and horticulture**.

- **Flow system with constant and flashing spraying** for different **pesticides and liquids**.

- Double back support for comfortable long tasks

- Insulated battery housing .



CORDLESS LAWNMOWER

PROCUT L20

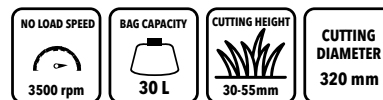

NEW



Power	18	V
No load speed	3500	rpm
Cutting height	30-55	mm
Bag capacity	30	L
Cutting diameter	320	mm
Wheel diameter	130	mm
Weight	10.6	Kg

- Lawnmower with **BRUSHLESS electric motor** for longer runtimes without mechanical wear. With a **32 cm cutting width**, it easily covers short to medium height grass up to 200 m².

- Features a central cutting height **adjustment from 30 mm to 55 mm**, and a **30 L collection bag**. Protective battery housing for one 18V battery compatible with the **L20 SERIES**.



Code

PROCUT L20	X	X	X	1.4244
PROCUT L2024	X	X	X	1.4603
PROCUT L2025	X	X	X	1.4604
PROCUT L2026	X	X	X	1.4605

- **Impact-resistant plastic housing**, handles dense grass growth without problems.

- **The 3-height adjustable**, foldable handle saves storage space even in the smallest sheds or garages. Transporting the lawnmower is easy thanks to its lightweight design and built-in carry handle.

- **Powerful brushless motor for increased efficiency**, significantly reducing heat build-up and considerably increasing motor life and battery life.



CHAIN SAW 36V

OLMO 350 36V L20

Voltage	36	V
Power	1200	W
Chain length	350	mm
Max. cutting diameter	330	mm
Cutting speed	19	m/s
Tank	160	ml
Weight	3.5	kg

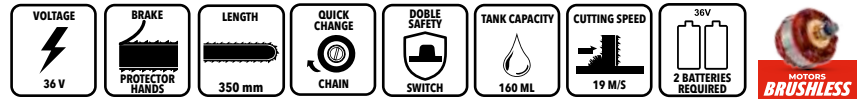

Double Battery



Code

	⚡	🔌	Code
OLMO 350 36V L20	X	X	1.3598
OLMO 350 36V L2024	2 x 4.0Ah	✓	1.3634
OLMO 350 36V L2025	2 x 5.0Ah	✓	1.3635

OLMO 350 36V L2026	2 x 6.0Ah	✓	1.3636
OLMO 350 36V L2027	2 x 7.5Ah	✓	1.4008

BLOWER 36V

VENTO 36V L20

No load speed, turbine	0-20000	rpm
Air speed	160	km/h
Noise level	95	dB-w(A)
Air flow rate	470-650-720	m³/h
Weight	2.4	kg



Double Battery



Code

	⚡	🔌	Code
VENTO 36V L20	X	X	1.2763
VENTO 36V L2024 Set	2 x 4.0Ah	✓	1.2822
VENTO 36V L2025 Set	2 x 5.0Ah	✓	1.2823
VENTO 36V L2026 Set	2 x 6.0Ah	✓	1.3312

- **BRUSHLESS motor** (increased performance and service life).
- **Powerful constant service motor 897.**
- **Double battery insertion**
- **Requires 2 matching batteries with the same amps and charge level**
- **Turbo feature to boost the tool's airflow for 2 seconds.**
- With **Boost Mode** system.
- Easily removable tube
- Double switch to prevent unintentional operation
- Non-slip handle
- Ergonomic design
- Shoulder carrying strap.

BRUSH CUTTER 36V

BRUSH CUTTER 36V L20 BRUSHLESS

No load speed	0 - 7100	rpm
Thread cutting diameter	ø350	mm
Wire thickness	ø2	mm
Disc size	ø250 x 2.5	mm
Weight	4	kg



Code

	⚡	🔌	🔧	Code
BC 36V L20	X	X	X	1.2764
BC 36V L2024 Set	2 x 4.0Ah	✓	✓	1.2825
BC 36V L2025 Set	2 x 5.0Ah	✓	✓	1.2826
BC 36V L2026 Set	2 x 6.0Ah	✓	✓	1.3313

- **BRUSHLESS motor** (increased performance and service life).
- **Telescopic brushcutter with wire and disc for cutting grass, weeds and bushes.**
- **High resistance aluminum structure.**
- **Double safety trigger with electronic speed regulator by pressure.**
- **Powerful brushless motor** for increased efficiency, significantly reducing heat build-up and considerably increasing motor life and battery life.
- **STAYER Li-ion HIGH-TECH, L20 battery** with overcharge, battery discharge, overheating and short circuit protection. LED charge indicator.
- Automatic wire feeding system.
- Double 180° rotating handle.
- Telescopic handle. 2 extendable tubes.

HEDGE TRIMMER / BRUSH CUTTER / GRASS CUTTER

NEW
Check Availability

MULTIGARDEN 36V

CORDLESS CHAIN SAW

Cutting speed		m/s
Tooth spacing	10"	
Bar length	25.4	cm
Weight	11	kg

HEDGE TRIMMER

No load speed	5500	spm
Bar length	39	cm
Weight	11	kg

Professional 4-in-1 multi-tool: Includes **hedge trimmer, pruning chain saw, brush cutter, and grass cutter heads.**

BRUSHLESS technology: High performance brushless motor.

Versatile design: Aluminum split tube for easy transport and storage.

Adaptable ergonomics: Equipped with a bike handle and a loop handle for total control in any position.



⚡ 🔋 📦 **Code**

MULTIGARDEN 36V L20	X	X	X	1.4606
MULTIGARDEN 36V L2022	2 x 2.0Ah	✓	✓	1.4607
MULTIGARDEN 36V L2024	2 x 4.0Ah	✓	✓	1.4608

VACUUM CLEANER

BVAC COMPACT L20

Power	18	V
Suction capacity	10	KPa
Tank volume	10	L
Max. suction capacity	7	L
Suction pipe diameter	Ø38	mm
Air flow rate	1.6	m³/min
Hose length	2	m
Weight	3.2	kg

- HEPA filter code 12.999
- 4 wheels
- Funnel nozzle
- Flat nozzle
- Hanging strap
- Flexible tube 2m
- Suction adapter



⚡ 🔋 📦 **Code**

BVAC COMPACT L20	X	X	1.3692
BVAC COMPACT L2012	1 x 2.0Ah	✓	1.3970
BVAC COMPACT L2022	2 x 2.0Ah	✓	1.3971
BVAC COMPACT L2014	1 x 4.0Ah	✓	1.3847
BVAC COMPACT L2024	2 x 4.0Ah	✓	1.3973

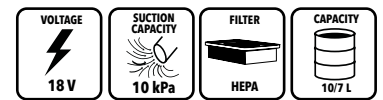

VACUUM CLEANER

VAC L20



- Extension tube.
- Standard brush.
- Brush nozzle.
- Corner nozzle.

Battery voltage lithium	18	V
Capacity	500	ml
Suction	4	Kpa
Weight	920	gr

⚡ 🔋 📦 **Code**

VAC L20	X	X	X	1.3438
VAC L2012	1 x 2.0Ah	✓	✓	1.3447
VAC L2022	2 x 2.0Ah	✓	X	1.3448

FLASH LIGHT L20

FL 18V L20



LED power	21	W
Luminous intensity	2500	lm
Battery life	3-6	h
Illumination modes	3	
Weight	0.9	Kg

⚡ 🔋 📦 **Code**

FL 18V L20	X	X	X	1.3106
FL 18V L2012 Set	1 x 2.0Ah	✓	✓	1.3308
FL 18V L2022 Set	2 x 2.0Ah	✓	✓	1.3309
FL 18V L2014 Set	1 x 4.0Ah	✓	✓	1.3310
FL 18V L2024 Set	2 x 4.0Ah	✓	✓	1.3311

BATTERY RADIO

RADIO L20

Code 1.3599



Transmitter coverage frequency	FM 87-108	MHz
Bluetooth transmission range	Máx. 15	m
Band		FM
USB Outputs	DC5 V / 1 A	
Dimensions	197x138x106	mm
Weight	0.9	kg

1. Mode selector: Aux / USB / FM station.
2. Station Rewind / Station Minus volume (-)
3. Station forward More volume (+)
4. Playback control for USB mode
5. Tune FM stations / pause button
6. On / off switch off switch

L20 SERIES BATTERIES - 18V

**L20 SERIES
LION STAYER**

- Lithium batteries for STAYER L20 SERIES

- Protected against: *Overcharge, discharge, overheating & shortcuts*

- Battery level indicator

NEW



2.0 Ah	4.0 Ah	4.0 Ah	5.0 Ah	6.0 Ah	7.5 Ah	8.0 Ah
Code 12.575	Code 12.1362	Code 12.577	Code 12.589	Code 12.858	Code 12.972	Code 12.1014
2.0Ah Battery 1 row with 5 lithium cells connected in line.	4.0Ah Battery 1 row with 5 lithium cells connected in line.	4.0Ah Battery 2 rows connected in parallel containing 5 Lithium cells each connected in line (for a total of 10 cells).	5.0Ah Battery 2 rows connected in parallel containing 5 Lithium cells each connected in line (for a total of 10 cells). Lithium INR 1865 25 R	6.0Ah Battery 3 rows connected in parallel containing 5 Lithium cells each connected in line (for a total of 15 cells). Lithium INR 18650 25 R	7.5Ah Battery 3 rows connected in parallel containing 5 Lithium cells each connected in line (for a total of 15 cells). Lithium INR 18650 25 R	8.0Ah Battery 2 rows connected in parallel containing 5 Lithium cells each connected in line (for a total of 10 cells). Lithium INR 21700 25 R
Voltage: 5 cells x 3.6 V/cell = 18 V Amps: 2.0 Ah	Voltage: 5 cells x 3.6 V/cell = 18 V Amps: 4.0 Ah	Voltage: 5 cells x 3.6 V/cell = 18 V Amps: 2.0 Ah/row x 2 Rows = 4.0 Ah	Voltage: 5 cells x 3.6 V/cell = 18 V Amps: 2.5 Ah/row x 2 Rows = 5.0 Ah	Voltage: 5 cells x 3.6 V/cell = 18 V Amps: 2 Ah/row x 3 Rows = 6.0 Ah	Voltage: 5 cells x 3.6 V/cell = 18 V Amps: 2.5 Ah/row x 3 Rows = 7.5 Ah	Voltage: 5 cells x 3.6 V/cell = 18 V Amps: 4 Ah/row x 2 Rows = 8 Ah

ST PROCELL L20

L20 BATTERY CHARGERS 18V

4.0 Ah	8.0 Ah	2.0 A	4.0 - 5.0 A								
		Code 12.576	Code 12.578								
<table border="1"> <thead> <tr> <th>3.0 Ah</th> <th>12.1386</th> </tr> </thead> <tbody> <tr> <td>4.0 Ah</td> <td>12.1384</td> </tr> <tr> <td>6.0 Ah</td> <td>12.1387</td> </tr> <tr> <td>8.0 Ah</td> <td>12.1385</td> </tr> </tbody> </table> <p>ST TABLESS L20 BATTERIES</p> <p>SUPER FAST CHARGING + SERVICE LIFE + POWER + RUNTIME - HEAT BUILD-UP</p> <p>NEW <i>Check Availability</i></p>		3.0 Ah	12.1386	4.0 Ah	12.1384	6.0 Ah	12.1387	8.0 Ah	12.1385	<p>Charger for batteries compatible with STAYER L20 SERIES.</p> <p>Intelligent charger battery charge level.</p>	<p>Protection against overcharge and overheat, increasing the battery lifespan.</p>
3.0 Ah	12.1386										
4.0 Ah	12.1384										
6.0 Ah	12.1387										
8.0 Ah	12.1385										

L20 SMART CHARGERS 18V

L20 CHARGER 18V

2.0 A - 6.0 A	DUAL	TRIPLE	QUADRUPLE
Code 12.916	Code 12.1388	Code 12.988	Code 12.1019
<p>Charger compatible with all STAYER L20 range.</p> <p>Integrated fan. Amperage sensing.</p> <p>FAST CHARGING</p>	<p>NEW <i>Check Availability</i></p> <p>12.0 A</p> <p>SUPER FAST CHARGING</p>	<p>NEW <i>Check Availability</i></p> <p>Dual 6.0 A</p> <p>On each port (3.0A at a time)</p>	<p>NEW <i>Check Availability</i></p> <p>12.0 A On each port (4.0A)</p>

STARTERKIT

STARTER KIT 2.0 A

Code 12.1020

1 Battery 2.0A + 1 Charger



STARTER KIT 4.0 A

Code 12.1021

1 Battery 4.0A + 1 Charger



STACKABLE CASES



Technical Data



CARRY CASE A (WITHOUT HANDLE)

Code 12.1001

Outer:
150 x 460 x 305 mm
Inner:
110 x 438 x 282 mm
Inner weight supported:
40 Kg
Outer weight supported:
20 Kg



CARRY CASE E - TROLLEY

Code 12.1005

Outer:
400 x 555 x 495 mm
Inner:
345 x 500 x 360 mm
Inner weight supported:
135 Kg
Outer weight supported:
120 Kg



CARRY CASE B

Code 12.1002

Outer:
150 x 460 x 305 mm
Inner:
110 x 438 x 282 mm
Inner weight supported:
40 Kg
Outer weight supported:
20 Kg



CASE ACCESSORIES

Inner Drawer

Code 12.1159



90 x 138 x 314 mm

Inner tray

Code 12.1301



CARRY CASE C

Code 12.1003

Outer:
150 x 510 x 365 mm
Inner:
82 x 475 x 318 mm
Inner weight supported:
60 Kg
Outer weight supported:
45 Kg



CARRY CASE G - TROLLEY WITH DRAWERS

Code 12.1016

Outer:
390 x 595 x 490 mm
Upper compartment:
75 x 500 x 362 mm
Inner compartment:
90 x 120 (x3) x 285 mm
Outer weight supported:
120 Kg



CARRY CASE D

Code 12.1004

Outer:
300 x 510 x 365 mm
Inner:
235 x 460 x 310 mm
Inner weight supported:
120 Kg
Outer weight supported:
60 Kg



SET A + C + D + E

Code 1.3947



SET B + C + D + E

Code 1.3941



SET C + D + E

Code 12.1022



SET C + D + G

Code 12.1023



L20 SERIES STANDS

STAND 1



WALL STAND 2 m

Code 1697.55

STAND 2



WALL STAND 1.6 M

Code 1697.48

STAND 3



STAND (WHEELS)

Code 1697.19

STAND 4



PROMO STAND

**Welding
Code 1697.40**

**General STAYER
Code 1697.36**

CARRY BAGS & TROLLEYS

USB BACKPACK

Code 12.906



MULTI SETS BAG

Code 1.2393



MAX OPENING BAG

Code 1.1944



TROLLEY

Code 1.2508





STAYER



L12 SERIES - 12V

L12 SERIES

LI-ION STAYER

Professional tools with high-tech Li-ion 12V batteries.

The red line corresponds to professional category tools. In the **Stayer L12 SERIES** you will find drills, hammer drills, screwdrivers, reciprocating saws, and sets to choose from.

A wide variety of 12V cordless tools.
Compatible with all products in the series.

DRILL / HAMMER DRILL / SCREWDRIVER 12V

PBL 122 DPK

Code 1.2990

PBL 122 DK

Code 1.2989



PBL 122 DPK **PBL 122 DK**

Battery voltage - Lithium	12	12	V
Battery capacity	2.0	2.0	Ah
No load speed	0-350/0-1350	0-350/0-1350	rpm
Impacts	0-21000	-	
Chuck insertion	3/8"	3/8"	UNF
Max. screw diameter	ø10	ø10	mm
Tightening Torque	32	32	Nm
Settings	25 + 2	18 + 2	
Weight	0.9	0.9	kg

- Impact screwdriver (aluminum gear box)

- 1/4" hexagonal insert for screwdriver bits
- Electronic speed control on the trigger.
- L.E.D. guide light.
- Reversible direction of rotation.

Included:

- HD-PE case
- 2.0 Ah charger
- x2 batteries 2.0 Ah
- Set of bits and wrenches



PBL 122 DPK
WITH PERCUSSION

PBL 122 DK
WITHOUT PERCUSSION

DRILL / HAMMER DRILL / IMPACT DRILL 12V

PBL 122 DPK + ISL 122 D

Code 1.3136

ISL 122 D

Battery voltage - Lithium	12	V
Battery capacity	2.0	Ah
No load speed	0-2400	rpm
Impacts	0-3000	ipm
Chuck insertion	1/4"	UNF
Tightening Torque	100	Nm
Weight	0.9	kg

- Impact screwdriver (aluminum gear box)

- 1/4" hexagonal insert for screwdriver bits.
- Electronic speed control on trigger.
- L.E.D. guide light.
- Reversible direction of rotation.

- HD-PE case
- 2.0 Ah charger
- x2 batteries 2.0Ah
- Set of bits and wrenches

Included:

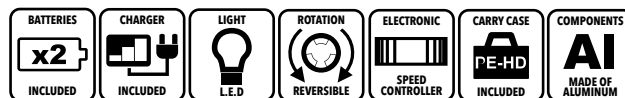

PBL 122 DPK

ISL 122 DK

CHARGER AN BATTERY - 12V

BATTERY 2.0 AH

Code 12.899



Compatible with
SSL 112 / SSL 122

CHARGER 2.0 A

Code 12.900



RECIPROCATING SAW 12V

SSL 112 D

Code 1.4506

SSL 122 DK

Code 1.4338

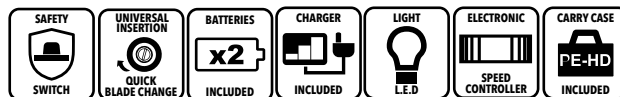

Battery voltage - Lithium	12	V
No load speed	0-3000	spm
Max. wood cutting	65	mm
Max. metal profile cutting	20	mm
Max pipe cutting	130	mm
Weight	1.3	kg



- Specially suited for single hand use
- Designed for plumbing & pruning: wood, metal sheets & metal pipes, drywall, PVC pipes, branches & logs.
- L.E.D guide light.
- Power controlled by trigger pressure.
- Quick blade change. Universal insertion

CHARGER AN BATTERY - 12V

BATTERY 2.0 AH

Code 12.899

CHARGER 2.0 A

Code 12.900

Compatible with
PBL 122 D / ISL 122 D/ SS L12 D



Included:
- x1 Pruning saw, x1 Wood saw, x1 Metal saw

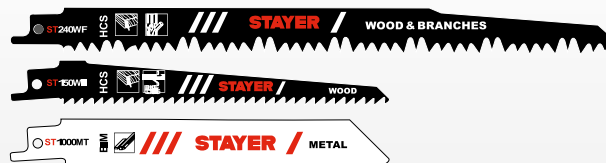

SCREWDRIVER 3.6V

PRO 36 3.6V

Code 1.3693

Battery voltage - Lithium	3.6	V
Battery capacity	850	mAh
Nominal load voltage	5	V
No load speed	0-280	/min
Chuck insertion	1/4"	UNF
Maximum automatic torque	1.2	Nm
Maximum manual torque	8	Nm
Weight	0.15	kg

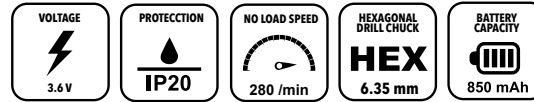

- **3.6V cordless screwdriver** with set of screwdriver bits included.
- **Battery integrated in the tool for greater maneuverability and comfort.**
- Wireless charging by USB Type-C port.



- 2 working modes: reversible for easy and effortless screwdriving and unscrewing.
- L.E.D indicator light
- Battery charge indicator.



SCREWDRIVER 3.6V

BL 50 CK

Code 1.2082

Battery voltage - Lithium	3.6	V
Battery capacity	1.3	Ah
No load speed	200	rpm
Chuck Capacity	1/4"	UNF
Tightening Torque	4	Nm
Max. screw diameter	ø8	mm
Settings	7	
Weight	0.3	kg

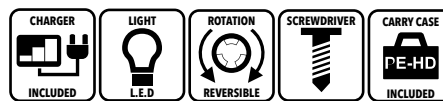

- **Screwdriver with 2 workmodes: die & gun**
- Built-in battery
- 10 Screwdriving settings + 1 drilling mode
- L.E.D light.
- Reversible.

- Included:**
- x1 Charger
 - 44 Accessories carry case:
 - 32 Screwdriver bits
 - 8 Socket wrenches
 - 2 Metal bits
 - 2 Adaptadors 1/4"



LED LAMP 3.6V

FL 700

Code 1.3032

Battery voltage - Lithium	3.6	V
Battery capacity	4.4	Ah
LED power	3-7	W
Luminous intensity	250-700	lm
Battery life	3-6	h
Charging port	USB-C	
Lighting modes	3	
Weight	460	g

- **Flashlight with integrated 3.7V battery**, light capacity equivalent to 7W LED, with USB port to charge mobile phones.
- **Different lighting modes** with different powers to adapt to all kinds of situations and needs:
 - Concentrated lighting mode 3W
 - Total area lighting mode 7W
 - Standard area lighting mode 3W
- **Rotative and foldable.**
- Magnet to stick it to shelves and scaffolding
- Hook to hang it from shelves
- **USB-C** port to use it as a mobile charger or power bank.
- Between 3 and 6 hours of uninterrupted light depending on the type of lighting chosen.



LED LAMP 3.6V

MINI SL 360

Code 1.4146

Battery voltage - Lithium	3.7	V
Battery capacity	0.8	Ah
LED power	4	W
Luminous intensity	400/200/20	lm
Battery life	2.5/4.5/60	h
Charging port	USB-C	
Lighting modes	3	
Weight	165	g

- **Ultra-compact and versatile design:** Mini pocket flashlight designed to offer powerful lighting in a compact and functional format.
- **Dual lighting system:** Equipped with dual LED technology.
- **Built-in lithium battery:** Includes an internal 3.7V and 1500mAh battery for long runtime and constant performance.
- **Fast charging via USB-C port.**
- **Robust construction:** Made with a combination of aluminum and ABS, ensuring a lightweight and impact-resistant design.





STAYER



DRILLS

STAYER Drills

An essential for the toughest jobs.
Whatever type of drill you need, we have it:
Hammer drills, portable electric drills, impact
wrenches...

SCREWDRIVER

384 B

Code 1.6008



DRYWALL



Power	600	W
No load speed	0 - 4500	rpm
Insertion	1/4"	UNF
Max. Self-tapping screws	N.14	ISO
Max. metric screws	ø8	M
Weight	1.8	kg

- Specially designed for drywall panels
- **INSERTION 1/4" UNF**
- Depth screwing regulator on the head.
- Power controlled by trigger pressure
- Reversible with lever located over the trigger.
- Ergonomic anti sliding handle

DRILL

TM 6 BA

Code 1.431



Power	400	W
No load speed	0 - 3000	rpm
Insertion	3/8" x 24	UNF
Chuck Capacity	ø1.5 - 6	mm
Weight	1.1	kg

- **No impacts drill**
- **Compact and lightweight design for wood & drywall**
- Keyless chuck
- Power controlled by trigger pressure
- Reversible with lever located over the trigger.

DRILL

TM 10 CA

Code 1.1369



Power	450	W
No load speed	0 - 3000	rpm
Insertion	3/8" x 24	UNF
Chuck Capacity	ø1.3 - 10	mm
Weight	1.3	kg

- **No impacts drill**
- **Compact and lightweight design for wood & drywall**
- Keyless chuck
- Speed regulator located on the trigger
- Reversible with lever located over the trigger.
- Anti sliding ergonomic handle
- Belt clip.

HAMMER DRILL

TM 700 BAK

Code 1.4591



Power	650	W
No load speed	0-3000	rpm
Impacts	0 - 44800	ipm
Chuck Capacity	ø2 - 13	mm
Insertion	1/2" x 20	UNF
Max. wood drilling	ø25	mm
Max. steel drilling	ø13	mm
Max. masonry drilling	ø16	mm
Weight	1.9	kg

- **Drill with 2 functions: drill & impact drill**
- Keyless chuck
- Speed regulator located on the trigger
- Reversible with button located over the trigger.
- Anti sliding ergonomic handle

- Included:**
- Auxiliary lateral handle
 - Depth regulator

HAMMER DRILL

TM 710 BAK

Code 1.1978

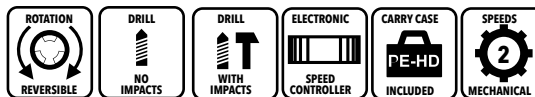

Power	710	W
No load speed	0 - 2800	rpm
Impacts	0 - 44800	ipm
Chuck Capacity	ø2 - 13	mm
Insertion	1/2" x 20	UNF
Max. wood drilling	ø25	mm
Max. steel drilling	ø13	mm
Max. masonry drilling	ø13	mm
Weight	1.9	kg



- Anti sliding ergonomic handle
- Safety lock.
- HD-PE Carry Case

Included:

- Auxiliary lateral handle
- Depth regulator

- Drill with 2 functions: drill & impact drill
- Keyless chuck
- Speed regulator located on the trigger
- Reversible with lever located over the trigger.

HAMMER DRILL

TM 851 BAK

Code 1.2684

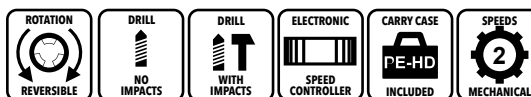

Power	850	W
No load speed	0 - 3000	rpm
Impacts	0 - 48000	ipm
Chuck Capacity	ø1.5 - 13	mm
Insertion	1/2" x 20	UNF
Max. wood drilling	ø28	mm
Max. steel drilling	ø13	mm
Max. masonry drilling	ø16	mm
Weight	2.4	kg



- Reversible with button located over the trigger.
- Anti sliding ergonomic handle
- Safety lock.

TM 851 BAK

Included:

- HD-PE Carry Case

- Drill with 2 functions: drill & impact drill
- Aluminum gearbox
- Speed regulator located on the trigger

HAMMER DRILL

TM 950 AK

Code 1.1516



Power	950	W
No load speed	0 - 1200 / 0 - 3000	rpm
Impacts	0 - 16000/0 - 44800	ipm
Chuck Capacity	ø1.5 - 13	mm
Insertion	1/2" x 20	UNF
Max. wood drilling	ø30	mm
Max. steel drilling	ø13	mm
Max. masonry drilling	ø16	mm
Weight	3	kg



Included:

- Auxiliary lateral handle
- Depth regulator
- HD-PE Carry Case

- Drill with 2 functions: drill & impact drill
- Aluminum gearbox with 2 Mechanical speeds
- Specially suited for metal at low rpm & construction at max rpm
- Metal keyless safety chuck
- Speed regulator located on the trigger. Reversible rotation

HAMMER DRILL

TM 1100

Code 1.1735

Power	1100	W
No load speed	0 - 1400/0 - 2880	rpm
Impacts	0 - 14400/0 - 40000	ipm
Chuck Capacity	ø16	mm
Insertion	5/8" x 16	UNF
Max. wood drilling	ø32	mm
Max. steel drilling	ø16	mm
Max. masonry drilling	ø16	mm
Weight	3.5	kg



- Drill with 2 functions: drill & impact drill
- Aluminum gearbox with 2 Mechanical speeds
- ø16 mm key chuck.
- Speed regulator located on the trigger. Reversible rotation



- Included:**
- Auxiliary lateral handle
 - Depth regulator

UNIVERSAL DRILL STAND

Code 12.937

- Neck 43 mm.
- Travel 68 mm.
- Inclination 0-90°.
- Weight 6.5 Kg
- SG 43 C



VACUUM ADAPTER

Code 12.1053



Universal Vacuum cleaner

For Drills & Hammers

CHUCKS



Zipper chuck
ø 13 mm - 1/2" x 20
Code 12.37



Zipper chuck
ø 16 mm - 5/8" x 16
Code 220.98



Automatic chuck
ø 6 mm - 1/2" x 20
TM 6 BA
Code 5014.235



Automatic chuck
ø 10 mm - 3/8" x 24
TM 10 DA
Code 8110.1559



Automatic chuck
ø 13 mm - 1/2" x 20
TM 710 BA
Code 12.508



Safety lock metal chuck
ø 13 mm - 1/2" x 20
TM 750 BA / TM 851 A
Code 12.26



Safety lock metal chuck
ø 13 mm - 1/2" x 20
TM 950 A
Code 12.536



Adapter for SDS PLUS Drill Chuck
ø 13 mm - 1/2"
Code 11.788

ADAPTER FOR DRILLING ANGLES AND SMALL SPACES

Code 12.1174



Insertion 1/4" (6.35mm)

ADAPTER FOR RIVETING MACHINE

Code 12.1054

Suitable for ⊕ 30 Nm screwdrivers.

Compatible for rivets:

- ø 2.4 mm
- ø 3.2 mm
- ø 4.0 mm
- ø 5.0 mm



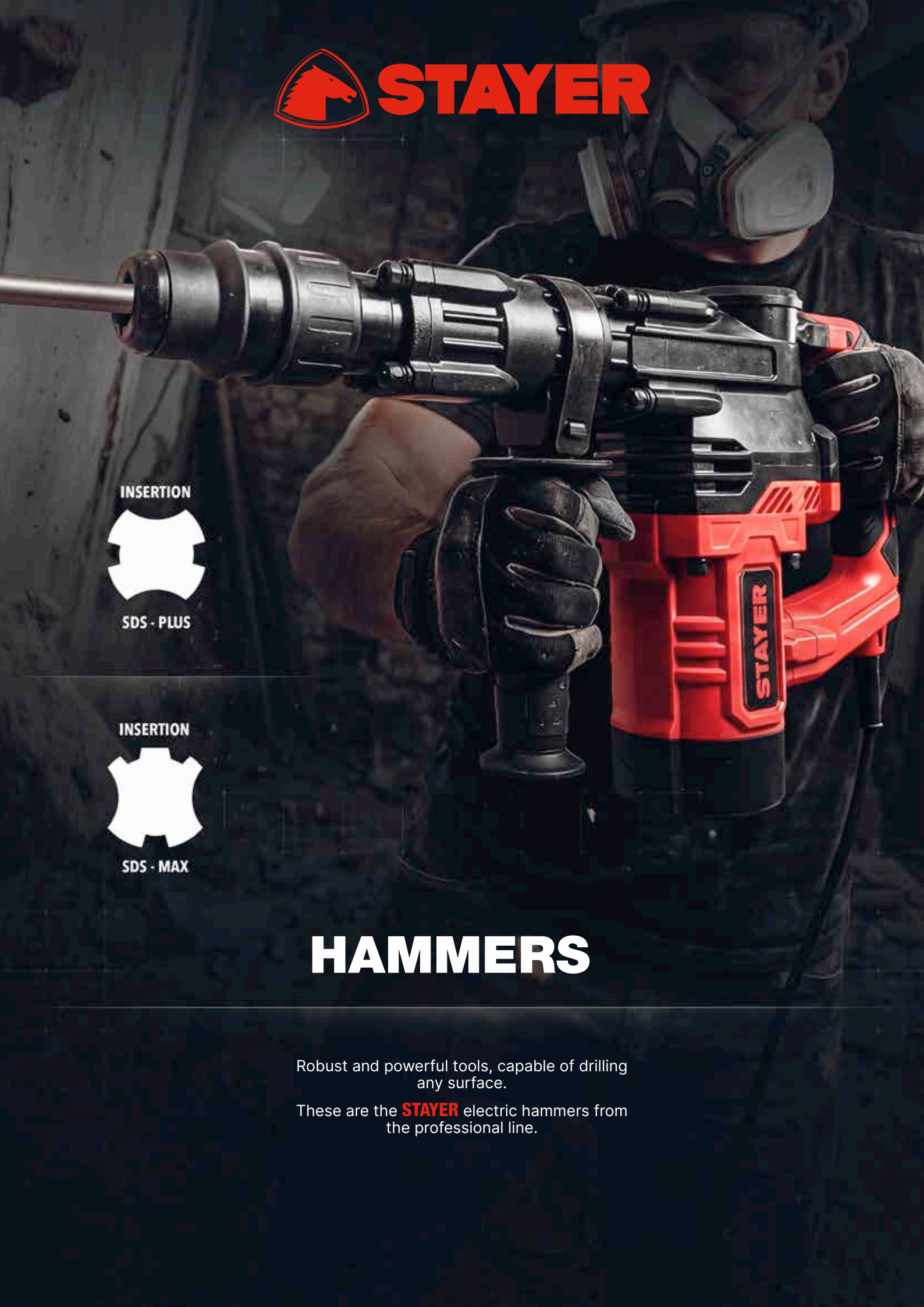

INSERTION



SDS - PLUS

INSERTION



SDS - MAX

HAMMERS

Robust and powerful tools, capable of drilling any surface.

These are the **STAYER** electric hammers from the professional line.

ROTARY HAMMER SDS-PLUS

HD 26 BK

Code 1.1418

Power	800	W
No load speed	0 - 1200	rpm
Impacts	0 - 5300	ipm
Impact energy	2.8	J
Insertion	SDS-PLUS	
Max. wood drilling	ø30	mm
Max. steel drilling	ø13	mm
Max. masonry drilling	ø26	mm
Max. core drilling	ø60	mm
Weight	2.8	kg



- Hammer with 3 Functions
- 1- Rotary for metal, wood & plastic
- 2- Rotary with percussion for construction materials
- 3- Chiseller for construction materials
- Vario - lock to adjust the chisel position
- Reversible by stator.
- Motor with Soft Start & safety clutch
- For concrete and masonry anchoring ø4-26 mm (optimal ø4-12 mm.)



- Included:**
- Auxiliary lateral handle
 - Depth regulator
 - HD-PE Carry Case

ROTARY HAMMER SDS-PLUS

HD 27 CK

Code 1.1967

Power	800	W
No load speed	0 - 1300	rpm
Impacts	0 - 5500	ipm
Impact energy	2.8	J
Insertion	SDS-PLUS	
Max. wood drilling	ø30	mm
Max. steel drilling	ø13	mm
Max. masonry drilling	ø26	mm
Max. core drilling	ø60	mm
Weight	2.8	kg



- Hammer with 3 Functions
- 1- Rotary for metal, wood & plastic
- 2- Rotary with percussion for construction materials
- 3- Chiseller for construction materials
- Vario - lock to adjust the chisel position
- Reversible by stator.
- Motor with Soft Start & safety clutch
- For concrete and masonry anchoring ø4-26 mm (optimal ø4-12 mm.)



- Included:**
- Auxiliary lateral handle
 - Depth regulator
 - HD-PE Carry Case

ROTARY HAMMER SDS-PLUS

HD 3 CK

Code 1.2314

Power	1050	W
No load speed	0 - 1100	rpm
Impacts	0 - 4600	ipm
Impact energy	5	J
Insertion	SDS-PLUS	
Max. wood drilling	ø32	mm
Max. steel drilling	ø13	mm
Max. masonry drilling	ø26	mm
Max. core drilling	ø60	mm
Weight	3.5	kg



- Hammer with 4 Functions
- 1- Rotary for metal, wood & plastic
- 2- Rotary with percussion for construction materials
- 3- Chiseller for construction materials
- 4- Vario - lock to adjust the chisel position
- Reversible by stator.
- VAT: vibration absorbing system



- Included:**
- Auxiliary lateral handle
 - Depth regulator
 - HD-PE Carry Case

ROTARY HAMMER SDS-PLUS

HD 6 DK

Code 1.2312



Power	1500	W
No load speed	0 - 850	rpm
Impacts	0 - 4300	ipm
Impact energy	7	J
Insertion	SDS-PLUS	
Max. wood drilling	ø40	mm
Max. steel drilling	ø13	mm
Max. masonry drilling	ø32	mm
Max. core drilling	ø80	mm
Weight	5	kg



- Hammer with 4 Functions

- 1- Rotary** for metal, wood & plastic
- 2- Rotary with percussion** for construction materials
- 3- Chiseller** for construction materials
- 4- Vario - lock** to adjust the chisel position
- **Reversible by stator.**
- **VAT:** vibration absorbing system

Included:

- Auxiliary lateral handle
- Depth regulator
- HD-PE Carry Case

DEMOLITION HAMMER SDS PLUS

MD 4 BK

Code 1.2921



Power	950	W
Impacts	4100	IPM
Impact energy	5	J
Insertion	SDS-PLUS	
Weight	3.5	kg



- Hammer with 2 Functions

- 1- Chiseller** for construction materials
- 2- Vario - lock** to adjust the chisel position
- Specialized mechanism with no rotation, only impacts
- **VAT:** vibration absorbing system

Included:

- Auxiliary lateral handle
- x1 Pointer
- HD-PE Carry Case

ROTARY HAMMER SDS-MAX

HD 45 BK

Code 1.3332



Power	1600	W
No load speed	0 - 560	rpm
Impacts	3800	ipm
Impact energy	10	J
Insertion	SDS-MAX	
Max. drill capacity	ø45	mm
Max. core drilling	ø100	mm
Weight	7	kg

VARIO-LOCK



- Constant speed by tacometer
- Electronic speed regulator
- Motor with safety clutch
- Soft Start
- VAT: vibration absorbing system

Included:

- Auxiliary lateral handle
- HD-PE Carry Case

- Hammer with 3 Functions

- 1- **Rotary with percussion** for construction materials
 - 2- **Chiseller** for construction materials
 - 3- **Vario - lock** to adjust the chisel position.
- 12 funciones de colocación del cincel en el portaherramientas.

ROTARY HAMMER SDS-MAX

HD 50 BK

Code 1.1741



Power	1200	W
No load speed	280 - 550	rpm
Impacts	2900	ipm
Impact energy	20	J
Insertion	SDS-MAX	
Max. drill capacity	ø45	mm
Max. core drilling	ø120	mm
Weight	8.5	kg



- Constant speed by tacometer
- Electronic speed regulator
- Motor with safety clutch
- Soft Start
- VAT: vibration absorbing system

Included:

- Auxiliary lateral handle
- HD-PE Carry Case

- Hammer with 3 Functions

- 1- **Rotary with percussion** for construction materials
- 2- **Chiseller** for construction materials
- 3- **Vario - lock** to adjust the chisel position.

DEMOLITION HAMMER SDS MAX

MD 5 K SDS MAX

Code 1.3691



Power	1300	W
Impacts	4100	IPM
Impact energy	12	J
Insertion	SDS-MAX	
Weight	6.5	kg



- VAT: vibration absorbing system

Included:

- Auxiliary lateral handle
- x1 Pointer
- HD-PE Carry Case

- Hammer with 2 Functions

- 1- **Chiseller** for construction materials
 - 2- **Vario - lock** to adjust the chisel position.
- 12 functions for positioning the chisel in the tool holder.

DEMOLITION HAMMER SDS MAX

MD 6 DK

Code 1.3619

Power	1500	W
Impacts	2600	IPM
Impact energy	16	J
Insertion	SDS-MAX	
Weight	6.2	kg

- Hammer with 2 Functions

- 1- Chiseller** for construction materials
- 2- Vario - lock** to adjust the chisel position.
- VAT:** vibration absorbing system

Included:

- Auxiliary lateral handle
- x1 Pointer
- HD-PE Carry Case



DEMOLITION HAMMER SDS MAX

MD 10 K

Code 1.1364

Power	1500	W
Impacts	1000 - 1900	IPM
Impact energy	6 - 25	J
Insertion	SDS-MAX	
Weight	10	kg

- Hammer with 2 Functions

- 1- Chiseller** for construction materials
- 2- Vario - lock** to adjust the chisel position.

- VAT:** vibration absorbing system
- Electronic power and impacts regulator
- Soft Start
- Carbon brush level indicator

Included:

- Auxiliary lateral handle
- x1 Pointer
- HD-PE Carry Case



DEMOLITION HAMMER HEX 30

MD 15 BK

Code 1.2377

Power	1750	W
Impacts	1900	ipm
Impact energy	45	J
Insertion	HEX 30	
Weight	15	kg

- High performance electropneumatic system for demolition works.
- Compact and aerodynamic for an easy access to reduced spaces.
- **Double VAT:** vibration absorbing system.

- Additional vibration reducing system with springs located over the insertion to further reduce the user's exhaustion.

Included:

- Auxiliary lateral handle
- x1 Chisel
- x1 Pointer
- Trolley



STANDS

Code 1697.14



DEMOLITION AND ROTARY HAMMERS

LONG LIFE



HAMMERS
LONG LIFE

POWER IS NOT EVERYTHING.

The new LONG LIFE range is designed to work longer hours, with less maintenance and a much longer service life.

- High performance motor
- VAT anti-vibration system
- Reinforced transmission
- Versatility in applications
- Mechanical safety clutch
- Soft start

ROTARY HAMMER SDS-PLUS

HD 6 K LONG LIFE

Code 1.3766

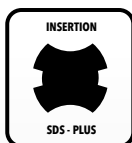

Power	1500	W
No load speed	920	rpm
Impacts	4400	ipm
Impact energy	5.5	J
Insertion	SDS-PLUS	
Max. wood drilling	ø40	mm
Max. steel drilling	ø13	mm
Max. masonry drilling	ø36	mm
Max. core drilling	ø80	mm
Weight	5.4	kg

- **1050W light rotary hammer** with **SDS-PLUS** insert with **4 functions**:
 - 1- Rotary with percussion; for building materials.**
 - 2- Chisel for building materials.**
 - 3- Vario-lock; adjusts the position of the chisel.**
 - 4- Rotary**
- **Electronic speed regulator** to adapt to all types of work and materials.
- **Mechanical safety clutch** to avoid

- twisting accidents if the bit gets stuck during the work.
- **Soft start** to avoid jerks and jolts when starting the tool. The machine reaches full power in 2 seconds.
- **Handle with "VAT" Vibration absorbing technology.** The hammer absorbs vibrations to facilitate long-lasting work.
- Adjustable side handle.

DEMOLITION HAMMER SDS-PLUS

MD 5 K LONG LIFE SDS PLUS

Code 1.3764

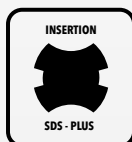

Power	1200	W
Impacts	3700	IPM
Impact energy	8	J
Insertion	SDS-PLUS	
Weight	4.7	kg

- **1200W light rotary hammer** with **SDS-PLUS** insert with **2 functions**:
 - 1- Chisel for building materials.**
 - 2- Vario-lock; adjusts the position of the chisel.**
- **12 functions for positioning the chisel** in the tool holder.
- Handle with **"VAT" anti-vibration system (Vibration absorbing technology)**. The hammer absorbs vibrations to facilitate long-lasting work.

ROTARY HAMMER SDS-MAX

HD 46 LONG LIFE

Code 1.3767

Power	1450	W
No load speed	650	rpm
Impacts	3200	ipm
Impact energy	12	J
Insertion	SDS-MAX	
Max. drill capacity	ø40	mm
Max. core drilling	ø100	mm
Weight	6.2	kg

- **1450W rotary hammer** with **SDS-MAX** insert with **3 functions**:
 - 1- Rotary with percussion; for building materials.**
 - 2- Chisel for building materials.**
 - 3- Vario-lock; regulates the position of the chisel.**
- **Electronic speed regulator** to suit all types of work and materials.

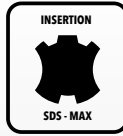

- **Unique chisel rotation system**, allowing the flat chisel to be locked in 16 positions.
- **Mechanical safety clutch** that prevents twisting accidents if the bit gets jammed during work.
- **Handle with "VAT" anti-vibration system** **Vibration absorbing technology**. The hammer absorbs vibrations to facilitate long-lasting work.
- **Adjustable side handle**.



DEMOLITION HAMMER SDS-MAX

MD 8 K LONG LIFE

Code 1.3765

Power	1300	W
Impacts	2400	IPM
Impact energy	20	J
Insertion	SDS-MAX	
Weight	7.3	kg

- **Lightweight 1300W rotary hammer** with **SDS-MAX** insert with **2 functions**:
 - 1- Chisel for building materials.**
 - 2- Vario-lock; adjusts the position of the chisel.**
- **Ø 40 mm cylinder**: provides extremely high demolition speed.
- **Unique chisel rotation system**: locks

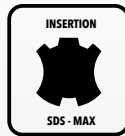

- the flat chisel at the desired working angle.
- **SDS-Max**: accepts SDS-Max chisels.
- **Handle with "VAT" Vibration absorbing technology**. The hammer absorbs vibrations to facilitate long-lasting work.

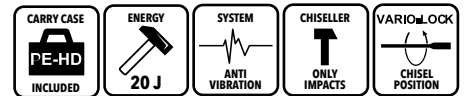

DEMOLITION HAMMER SDS-MAX

MD 11 K LONG LIFE

Code 1.4474

Power	1350	W
Impacts	900-1800	IPM
Impact energy	25	J
Insertion	SDS-MAX	
Weight	10	kg

- **Lightweight 1350W rotary hammer** with **SDS-MAX** insert with **2 functions**:
 - 1- Chisel for building materials.**
 - 2- Vario-lock; adjusts the position of the chisel.**
- **Ø 45 mm cylinder**: provides extremely high demolition speed.
- **Unique chisel rotation system**: locks

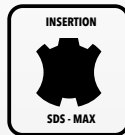

- the flat chisel at the desired working angle.
- **SDS-Max**: accepts SDS-Max chisels.
- **Handle with "VAT" Vibration absorbing technology**. The hammer absorbs vibrations to facilitate long-lasting work.

NEW

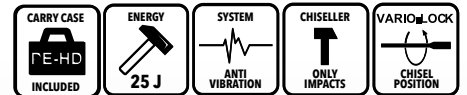



PAINTING WORK MACHINES

STAYER painting works machines offer efficient and professional mixing and painting for walls and other surfaces: Wall sanders, mixers, and paint strippers are some of our solutions for professional painting or smoothing tasks.



HOT AIR GUN

SU 650 EDK

Code 1.834

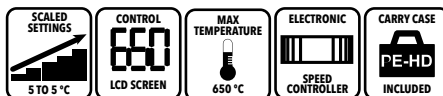

Power	2000	W
Airflow	250 - 500	l/min
Temperature	50 - 650	°C
Weight	0.9	kg

- Hot air gun with ceramic resistance
- Temperature & Airflow adjustable by microprocessor
- L.C.D screen with temperature control by 5 °C steps & airflow in 5 levels.
- Dries and peels varnish off. Folds plastic materials. Separates adhesive papers.

Included:

- Nozzle set
- HD-PE Carry Case



HOT AIR GUN

DX 1800 B

Code 1.2951

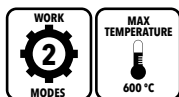

Power	1800	W
Airflow	300 - 500	l/min
Temperature	350 - 600	°C
Weight	0.9	kg

- Hot air gun with ceramic resistance
- 2 preset working modes airflow & Temperature:
 - 1- 350°C with 300 l/min
 - 2- 600°C with 500 l/min
- Dries and peels varnish off. Folds plastic materials. Separates adhesive papers.
- Reinforced head against high temperatures.

Included:

- x3 Nozzles
- x1 Scraper



MIXER

M 1200 D

Code 1.3612

M 1200 DK

Code 1.4113

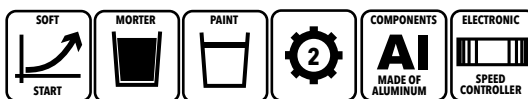

Power	1200	W
No load speed	180 - 430 / 300 - 680	rpm
Whisk diameter	120	mm
Insertion	M14	
Weight	4.8	kg

- Mixer with 2 mechanical speeds.
- Aluminum body.
- S1 continuous duty motor.
- Suitable for both paint and liquid materials, as well as cements and viscous materials.
- 6-speed electronic variator.
- Ergonomic handles.

Included:

- x1 whisk H2 - ø120 mm

M 1200 DK

Code 1.4113

Included:

- HD-PE Carry Case



MIXER

M 1200 C

M 1200 CK

Code 1.1474

Code 1.1475

Power	1200	W
No load speed	200-400 / 350-700	rpm
Whisk diameter	ø120	mm
Insertion	M14	
Weight	4.8	kg

- Mixer with 2 Mechanical speeds
- Aluminum structure
- S1 constant service motor
- Suitable for paints and liquids as well as mortar and viscous materials
- 6 Levels electronic speed regulator.
- Ergonomic handles

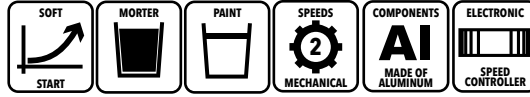

Included:
- x1 whisk H2 - ø120 mm

M 1200 CK Included:
- HD-PE Carry Case



MIXER

M 1600

M 1600 K

Code 1.1476

Code 1.1477

Power	1600	W
No load speed	180-380 / 300-650	rpm
Whisk diameter	ø160	mm
Insertion	M14	
Weight	6	kg

- Mixer with 2 Mechanical speeds
- Aluminum structure
- S1 constant service motor
- Suitable for paints and liquids as well as mortar and viscous materials
- 6 Levels electronic speed regulator.
- Ergonomic handles
- Soft Start

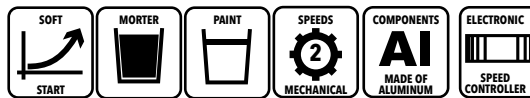

Included:
- x1 whisk H2 - ø140 mm

M 1600 K Included:
- x1 whisk H3 - ø140 mm
- x1 whisk H2 - ø160 mm
- HD-PE Carry Case



MIXER

M 2000

Code 1.4514

Power	2000	W
No load speed	180/400/300/700	rpm
Whisk diameter	ø140	mm
Insertion	M14	
Weight	5.4	kg

- Mixer with 2 Mechanical speeds
- Aluminum structure
- S1 constant service motor
- Suitable for paints and liquids as well as mortar and viscous materials
- 6 Levels electronic speed regulator.
- Ergonomic handles
- Soft Start

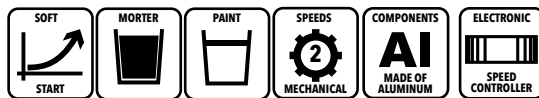

Included:
- x1 whisk H2 - ø140 mm

NEW



TELESCOPIC WALL SANDER

LP 710 DT

Code 1.2420



Power	710	W
No load speed	1000 - 2100	rpm
Work height	1100 - 1700	mm
Plate size	ø225	mm
Vacuum coupling	ø37.5	mm
Head tilting	90	°
Weight	4.4	kg
Hose	3.5	m

- Wall sander with anti dust sealed motor.
- Direct transmission without shaft
- Built-in vacuuming system.
- Coupling for an external vacuum cleaner.
- 6 levels electronic speed regulator

Included:

- 6 Sanding sheets ø225 mm (P80, P100, P120, P150, P180, P240)
- Hose 3.5 m
- Vacuum coupling



TELESCOPIC WALL SANDER

LP 750 AVS K

Code 1.3314



Power	750	W
No load speed	1000 - 1850	rpm
Work height	135-180	cm
Plate size	ø225	mm
Plate	8	agujeros
Head tilting	120	°
Weight	3.5	kg

- Wall sander
- Direct transmission
- Integrated suction system.
- Tilting head to avoid marks on the walls
- Foldable for easy transport and storage.
- Removable carter for edges and corners sanding.
- LED light 360°.
- Lightweight 3.5 kg.
- Reinforced aluminum structure.

TELESCOPIC FOLDABLE

AVS
AUTOMATIC VACUUM SYSTEM

INTEGRATED SUCTION NO NEED FOR ADDITIONAL VACUUM CLEANER



TELESCOPIC WALL SANDER

LP 700 BRUSHLESS

Code 1.2912

Power	500	W
No load speed	1000 - 2100	rpm
Plate size	ø225	mm
Vacuum coupling	ø38 - 47	mm
Head tilting	90	°
Weight	3.5	kg
Hose	4	m

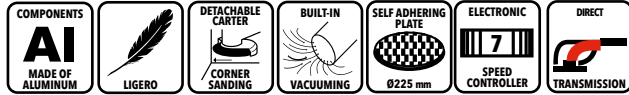

LIGHT FOLDABLE



Wall sander with brushless motor located on the head.

- **Powerful brushless motor** for increased efficiency, significantly reducing heat build-up and considerably increasing motor life and battery life.
- **Foldable for an easy transport and storage.**
- **Direct transmission**
- **Tiltable head to avoid wall scratching**
- **Lightweight 3.5 kg**
- Reinforced aluminum structure
- Coupling for an external vacuum cleaner.

- Detachable carter for edges and corners sanding.
- 7 levels electronic speed regulator

Included:
 - Hose 4 m
 - Vacuum coupling

HAND WALL SANDER

HP 1010

Code 1.2129

Power	1010	W
No load speed	1000 - 1950	rpm
Plate size	ø225	mm
Weight	2.8	kg

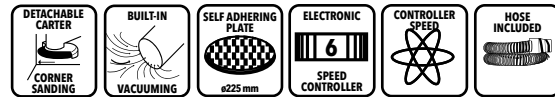

ERGONOMIC HANDLE

SPEED REGULATOR



- **Wall sander with horizontal motor.**
- **Built-in vacuuming system.**
- **Adjustable disc height**
- Removes plastic paint, gotele & flattens drywall.
- Coupling for an external vacuum cleaner.
- Designed for both walls and ceiling sanding.
- Detachable carter for edges and corners sanding.
- 6 levels electronic speed regulator

Included:
 - 6 Sanding sheets ø225 mm (P80, P100, P120, P150, P180, P240)
 - Hose
 - Vacuum coupling

6 sanding sheets ø225 mm



HAND WALL SANDER

HP 1200 E

Code 1.3316



Power	1200	W
No load speed	2600	rpm
Plate size	ø225	mm
Weight	2.5	kg

- Led light.

- Variable speed control 6 positions.
- Separate dust absorption system, which protects the motor from dust ingress.
- Removable carter for edges and corners sanding.
- Large handle.
- Dust bag with carrying belt.
- 360° LED light.

Included:

- 6 Sanding sheets (gr 80/100/120/150/180 y 240 gr).
- 1 Adapter
- Dust bag



WALL AND FLOOR TROWEL

CWS 410

Code 1.3145



Power	750	W
No load speed	100	rpm
Plate size	ø375	mm
Diameter alisado	ø410	mm
Weight	3.5	kg

- The electroportable trowel is ideal for troweling, sanding, scraping, cleaning and roughing of walls and ceilings of mortars, plasters, thermal insulation panels...
- 750W polishing / sanding / smoothing machine with self-adhesive plate for smoothing, polishing and finishing of cement works.
- Balanced handles for easy sliding on the surface plastic plate for rough smoothing, sponge pad for finishing smoothing 375 mm sanding plate for covering large surfaces.

- Thermal smoothing wall grinding.
- Speed regulator to adapt the tool to the work to be done.
- Auxiliary upper handle for stable and homogeneous polishing.
- Spindle lock button for maximum safety against accidental start-up.
- Extension accessory (separate).



Included:



Smoothing plate
Code 12.930

Suitable for rough smoothing and compacting concrete and structuring plasters.



Sandpaper
Code 12.929

For sanding insulation boards, polystyrene boards, mineral insulation.
24" grit



Sponge
Code 12.928

For finishing smoothing and cleaning of wet cement.
410mm

BRUSHLESS PAINT SPRAY GUN

AIRLESS ST 2.0

Code 1.4330



MOTORS
BRUSHLESS

NEW



Power	1200	W
Max. Spray pressure	3000	psi
Maximum flow rate	2.0	l/min
Nozzle	517	
Hose	13	m
Weight	14	Kg

- **Spray pressure adjustment** for different materials.
- Powerful **1200W** motor with a higher flow rate.
- Longer service life.
- **Simple structure, easy to maintain and clean**, cost-saving.
- **Wheeled cart design** for greater convenience.
- The cart hose can be easily placed on the handle.

Included:

- 1 x 50 cm extension rod
- 1 x 10 m high-pressure hose
- 1 x spray gun
- 1 x 517 nozzle
- 1 x suction tube
- 1 x return tube

BRUSHLESS PAINT SPRAY GUN

AIRLESS ST 2.5 PRO

Code 1.4331

NEW



MOTORS
BRUSHLESS



Power	1400	W
Max. Spray pressure	3300	psi
Maximum flow rate	2.5	l/min
Nozzle	525	
Hose	13	m
Weight	14	kg

- **High-pressure Airless system** for even and streak-free spraying.
- **High spray flow rate** for fast and efficient work.
- **1400W motor**, designed for continuous and demanding use.
- **525 nozzle**, ideal for large surfaces and high viscosity paints.
- **Uniform spraying** with a professional finish without excessive dilution.

Included:

- 1 x 50 cm extension rod
- 1 x 13 m high-pressure hose
- 1 x spray gun
- 1 x 525 nozzle
- 1 x suction tube
- 1 x return tube



ANGLE GRINDERS

Versatile angle grinders for cutting and grinding all types of materials. Thanks to their easy disc change, they can be used by both DIY enthusiasts and industry professionals.

MINI ANGLE GRINDER

SAB 720 B

Code 1.3432



SAB 721 B

Code 1.3495

SAB 720 B

SAB 721 B

Power	720	W	720	W
No load speed	11000	rpm	11000	rpm
Disc diameter	115	mm	125	mm
Spindle thread	M14		M14	
Weight	1.6	kg	1.6	kg

- **Reduced and compact angle grinder**
- Extremely versatile & lightweight.

SAB 721
Disc ø125 mm



SAB 780 C

Code 1.3601



Power	780	W
No load speed	11000	rpm
Disc diameter	ø115	mm
Spindle thread	M14	
Weight	1.45	kg

- **Reduced and compact angle grinder**
- Extremely versatile & lightweight.
- Anti abrasion systems:



SAB 800 F

Code 1.3776



SAB 800 F

SAB 801 F

Power	800	W	800	W
No load speed	11000	rpm	11000	rpm
Disc diameter	115	mm	125	mm
Spindle thread	M14		M14	
Weight	1.7	kg	1.7	kg

- **Angle grinder with compact & balanced design.**
- Anti abrasion systems: double shielding, protection polymer, special cording & collector barrier.
- Assembled under pressure with 2 safety bolts

- Cooling systems: elongated rotor, cooling fan & 6 grids on the head.

Included:
- 2 positions auxiliary handle.

SAB 801 F
Disc ø125 mm

SAB 900 PS

Code 1.4467



SAB 901 PS

Code 1.4611

SAB 900 PS

SAB 901 PS

Power	900	W	900	W
No load speed	11000	rpm	11000	rpm
Disc diameter	115	mm	125	mm
Spindle thread	M14		M14	
Weight	1.9	kg	1.9	kg

- **Paddle switch.**
- **Specially designed for two-handed use.**

Included:
- 2 positions auxiliary handle.

SAB 901 PS
Disc ø125 mm



SAB 1000 B

Code 1.3632



SAB 1001 B

Code 1.3633

SAB 1000 B

SAB 1001 B

Power	1000	W	1000	W
No load speed	11000	rpm	11000	rpm
Disc diameter	115	mm	125	mm
Spindle thread	M14		M14	
Weight	1.6	kg	1.6	kg

- **Angle grinder with compact & balanced design.**
- Double shielded bearings
- Anti abrasion systems: double shielding, protection polymer, special cording & collector barrier.
- Assembled with 2 safety bolts
- Cooling systems: elongated rotor, cooling fan

Included:
- 2 positions auxiliary handle.

SAB 1001 B
Disc ø125 mm



MINI ANGLE GRINDER Ø125 mm

SAB 1011 CE

Code 1.3631



Power	1000	W
No load speed	2800 - 11000	rpm
Disc diameter	Ø125	mm
Spindle thread	M14	
Weight	1.6	kg

- Angle grinder with compact & balanced design.

- Double shielded bearings
- Anti abrasion systems: double shielding, protection polymer, special cording & collector barrier.
- Assembled with 2 safety bolts
- Cooling systems: elongated rotor, cooling fan & 6 grids on the head.

Included:

- 2 positions Auxiliary handle.

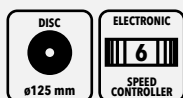

MINI ANGLE GRINDER Ø125 mm

SAB 1101 CS

Code 1.2827



INDUSTRIAL USE

Power	1100	W
No load speed	2800 - 11000	rpm
Disc diameter	Ø125	mm
Spindle thread	M14	
Weight	1.8	kg

- Constant power under load.

- Flat head for narrow areas
- Long body, 28 cm without the head.
- 6 Levels electronic speed regulator.
- External carbon brush replacement.

Included:

- 2 positions Auxiliary handle.

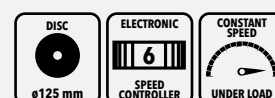

MINI ANGLE GRINDER Ø125 mm

SAB 1351 CS

Code 1.1786



Power	1300	W
No load speed	2800 - 11000	rpm
Disc diameter	Ø125	mm
Spindle thread	M14	
Weight	1.8	kg

- Maximum power 1300W

- Tacometer to keep constant power under load.
- 6 Levels electronic speed regulator
- Soft Start.
- External carbon brush replacement.

Included:

- 3 positions Auxiliary handle.

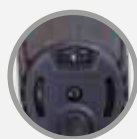

MINI ANGLE GRINDER Ø125 mm

SAB 1501

Code 1.3644



NEW

Power	1500	W
No load speed	11000	rpm
Disc diameter	Ø125	mm
Spindle thread	M14	
Weight	2.3	kg

- Maximum power 1500W

- Soft Start.
- External carbon brush replacement.

Included:

- 2 positions Auxiliary handle.

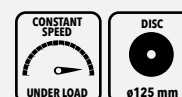

MINI ANGLE GRINDER Ø125 mm

SAB 1201 IND

Code 1.2477

Power	1200	W
No load speed	11000	rpm
Disc diameter	Ø125	mm
Spindle thread	M14	
Weight	1.8	kg

- Mini angle grinder for industrial use.
- Reinforced protections.
- No electronic plate for power surges.
- External carbon brush replacement.
- Ready for industrial use under adverse conditions.

Included:
- 3 Positions auxiliary handle

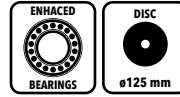

INDUSTRIAL USE



MINI ANGLE GRINDER Ø125 mm

SAB 1401 CE IND

Code 1.2793

Power	1400	W
No load speed	2800 - 10000	rpm
Disc diameter	Ø125	mm
Spindle thread	M14	
Weight	2.2	kg

- Mini angle grinder for industrial use.
- Angle grinder with tachometer to keep constant power under load.
- With electronic speed regulator.
- External carbon brush replacement.
- Ready for industrial use under adverse conditions.

Included:
- 2 Positions auxiliary handle

Variable speed with tachometer, facilitates the use for roughing on different materials, simply by changing the machine revolutions and the working tool.

Accessories

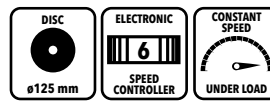

INDUSTRIAL USE



Aspiration Carter

Code 12.459

Epoxy Grinding
Code 5.865



Mortar Grinding
Code 5.1321



MINI ANGLE GRINDER Ø125 mm

SAB 1701CS IND

Code 1.3138

SAB 1750 CS IND

Code 1.3112

	SAB 1701 CS IND	SAB 1750 CS IND	
Power	1700	1700	W
No load speed	2800-10000	2800-10000	rpm
Disc diameter	Ø125	Ø150	mm
Spindle thread	M14	M14	
Weight	3.0	3.0	kg

- Mini angle grinder for industrial use.
- Angle grinder with tachometer to keep constant power under load.
- With electronic speed regulator.
- External carbon brush replacement.
- Ready for industrial use under adverse conditions.

Included:
- 2 Positions auxiliary handle

Variable speed with tachometer, facilitates the use for roughing on different materials, simply by changing the machine revolutions and the working tool.

Accessories

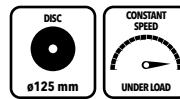

INDUSTRIAL USE



Epoxy Grinding
Code 5.865



Mortar Grinding
Code 5.1321



Aspiration Carter

Code 12.459

ANGLE GRINDER ø230 mm

AGR 2000

Code 1.2792



Power	2000	W
No load speed	6500	rpm
Disc diameter	ø230	mm
Spindle thread	M14	
Weight	4.2	kg

- Specially suited for workshops.
- External carbon brush replacement.
- Soft Start

Included:

- 3 Positions auxiliary handle



ANGLE GRINDER ø180 / ø230 mm

AGR 21-18 C

Code 1.2701

AGR 22-23 D

Code 1.3730

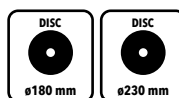

AGR 21-18 C

AGR 22-23 D

Power	2100	2200	W
No load speed	8000	6500	rpm
Disc diameter	ø180	ø230	mm
Spindle thread	M14	M14	
Weight	4.5	4.5	kg

- Specially suited for workshops.
- External carbon brush replacement.
- Soft Start

Included:

- 3 Positions auxiliary handle



ANGLE GRINDER ø180 / ø230 mm

AGR 24-23 CAL

Code 1.1816

AGR 24-18 CAL

Code 1.1895

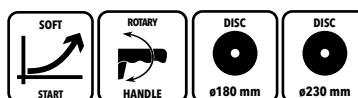

AGR 24-23 CAL

AGR 24-18 CAL

Power	2400	2400	W
No load speed	6500	8000	rpm
Disc diameter	ø230	ø180	mm
Spindle thread	M14	M14	
Weight	4.7	4.7	kg

- **Powerful S1 constant service motor 2400W.**
- **Rear rotary handle**
- Paddle switch with safety lock trigger & NVR system
- Specially suited for workshop, quarry and construction tasks.
- External carbon brush replacement.
- Soft Start

Included:

- 3 Positions auxiliary handle
- **OPTIONAL:** HD-PE Carry Case



ANGLE GRINDER \varnothing 230 mm

SAB 26-23 AL NS

Code 1.1689

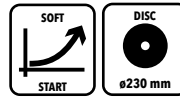

Power	2600	W
No load speed	6500	rpm
Disc diameter	\varnothing 230	mm
Spindle thread	M14	
Weight	5.4	kg



- **Powerful S1 constant service motor 2600W.**
- Quality components: ball bearings & needles on every support. High performance sprocket & core.
- Specially suited for workshop, quarry and construction tasks.
- External carbon brush replacement.
- Soft Start

Included:
- 3 Positions auxiliary handle

DIE GRINDER

SD 27 CE

Code 1.1705

Power	750	W
No load speed	10000 - 30000	rpm
Collet	\varnothing 6 / \varnothing 6.3 / \varnothing 8	mm
Weight	1.4	kg

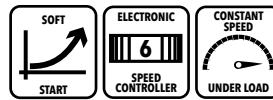

- **Great power (750W) die grinder with Speed regulator for mounted points and burrs with \varnothing 6 / \varnothing 6.3 / \varnothing 8 mm shaft.**
- **Soft Start** the tool reaches its full power 2 seconds after being switched on.
- **Electronic speed regulator with 6 levels** ranging from 10.000 up to 30.000 rpm
- **Built-in tacometer** to keep constant power under load.
- Specially designed motor to withstand dust.
- Electronic system to limit the input current on the tool switch on, keeping the constant speed even at low rpm.
- Safety switch against unintentional activations.
- Specially designed to grind weld lines, polish & brighten all types of materials, from wood to paint or metal. Excelet performance removing metal barbs & sharpening.
- Specially suited for corundum mounted burrs, flap wheels, hard metal burrs & wire brushes.

Included:
- x3 collets
 \varnothing 6 mm
 \varnothing 6.3 mm
 \varnothing 8 mm



CONCRETE CUTTING MACHINE \varnothing 350 mm

CCM 350

Code 1.3352

Power	2800	W
Voltage	220/230	V
No load speed	4500	rpm
Disc diameter	\varnothing 300-350	mm
Max. cutting depth	300 (125) / 350 (150)	mm
Spindle thread	25,4	mm
Weight	11	Kg

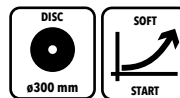

- Particularly suitable for construction work that requires cutting of bulky or deep pieces.
 - Soft Start
 - Cooling system.
 - PRCD protection switch
- Included:**
- Disc \varnothing 350mm

ANGLE GRINDER ø125 mm

SAB BL 1901 E

Code 1.3876

Power	1900	W
No load speed	3000 - 10000	rpm
Disc diameter	125	mm
Spindle thread	M14	
Weight	1.6	kg

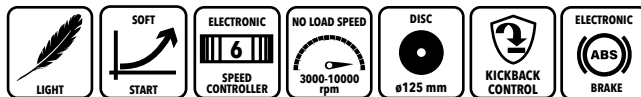

NEW
Check Availability

ULTRALIGHT

Electronic Regulator 6 speed



- Angle grinder 1900W motor, designed for cutting, grinding, roughing, sanding, polishing, satin finishing of all types of materials: metals, wood, natural and artificial stone, porcelain materials and plastics.
- High quality and resistant components, specially prepared for heavy duty work in adverse environments.
- Protection against overheating and overload, prolonging the life of the motor.
- Auxiliary handle 2 positions.

- Dial with 6 positions to adapt the rotation speed to the task at hand.
- NVR system.
- Removable cooling grid.
- Instant brake when the switch is released.
- Soft start.
- Motor completely protected against metal particles.

Industrial performance comparison: SAB BL 1901 E vs. 1200W Brushed Angle Grinder

This technical comparison uses performance test data to highlight how the SAB BL 1901 E model's technology outperforms conventional angle grinders.



Maximum power
1200W brushed angle grinder curve
The SAB BL 1901 reaches a maximum power of 2072W.

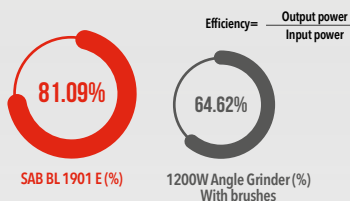

81.09% efficiency:
Maintains solid efficiency under maximum load, outperforming traditional brushed motors in its category.

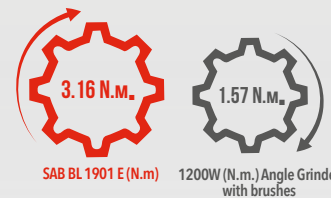

Maximum torque of 3.16 N.m.
Robust torque capacity for demanding jobs, maintaining operational stability at high RPM.

ANGLE GRINDER ø230 mm

AGR BL 5000

Code 1.3877

Power	5000	W
No load speed	6200	rpm
Disc diameter	230	mm
Spindle thread	M14	
Weight	4.5	kg

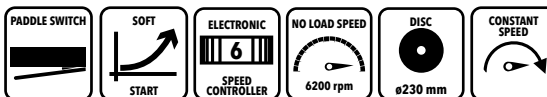

Handle with anti-vibration

IMPROVED GRINDING SPEED

High Pressure Die Cast Aluminum

- Angle grinder with a powerful 5000W motor for ø230 mm discs.
- Specially suited for metal.
- For cutting, grinding, roughing, sanding, polishing, and satin-finishing of all types of materials: metals, wood, natural and artificial stone, porcelain materials, and plastics.
- Soft start.



Industrial performance comparison: AGR BL 5000 vs. 2600W Brushed Angle Grinder

This technical comparison uses performance test data to highlight how the AGR BL 5000 model's technology outperforms conventional angle grinders.

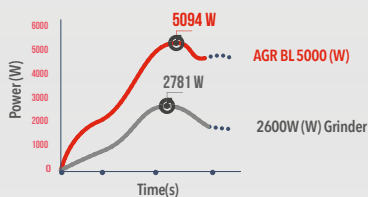

Maximum power
In load tests, the AGR BL 5000 reached a maximum power peak of 5094W, vastly outperforming traditional 2600W models in working capacity.

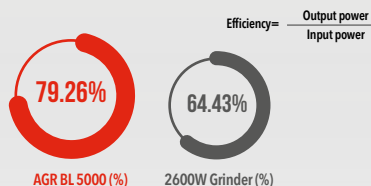

Energy efficiency over 79%
The AGR 5000 reaches its peak efficiency (79.26%) under high torque conditions, optimizing energy consumption.

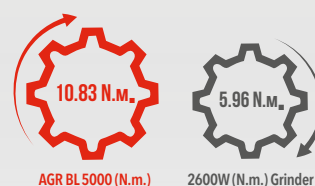

Maximum torque of 10.83 N.m.
Maintains a constant turning force, even under the most demanding loads.

Angle grinder suction housing

ASPIRATION CARTER FOR CUTTING

Code 12.465

Aspiration carter for cutting construction materials.
Grinder neck Ø 39 - 52mm, using washers.

- Coupling for suction housing.

COLOR	SIZE	WALL THICKNESS
BLACK	51.5 x 45 mm	3 mm
BLACK	51.5 x 42 mm	4.5 mm (STAYER compatible)
BLACK	51.5 x 40 mm	5.5 mm
BLACK / RED	51.5 x 44 mm	3.45 mm
METAL	51.5 x 48 mm	1.5 mm (STAYER compatible)
BLACK / RED	51.5 x 43 mm	4 mm



6 WASHERS



MINI GRINDER CUTTING WITHOUT SUCTION HOUSING



MINI GRINDER CUTTING WITH SUCTION HOUSING

Aspiration carter for roughing 125 mm

Code 12.459

Aspiration carter for roughing construction materials.
Grinder neck Ø 39 - 52mm, using washers.

- Coupling for suction housing.

COLOR	SIZE	WALL THICKNESS
BLACK	51.5 x 45 mm	3 mm
BLACK	51.5 x 42 mm	4.5 mm (STAYER compatible)
BLACK	51.5 x 40 mm	5.5 mm
BLACK / RED	51.5 x 44 mm	3.45 mm
METAL	51.5 x 48 mm	1.5 mm (STAYER compatible)
BLACK / RED	51.5 x 43 mm	4 mm



Quick tightening nut

Code 11.4624

Compatible with all M14 brands
One-click locking of M14 nuts.
Diameter Ø 50mm.



Angle Grinder support Ø115-125mm

Code 12.939



Grinder Support Assembly



STAYER



POWER TOOLS FOR: WOOD • METAL • CONSTRUCTION

All STAYER tools and saws

Feature an ergonomic design that guarantees comfort and safety at work, as well as maximum cutting capacity, whatever the application: wood, metal, etc.

DIAMOND DISC WALL CHASER ø125 mm

CD 125

Code 1.1254



Power	1500	W
No load speed	8500	rpm
Disc diameter	ø125	mm
Cutting width	7 - 30	mm
Max. cutting depth	3 - 29	mm
Weight	5	kg

Included:

- Auxiliary handle
- Support wheel
- x2 diamond discs ø125 mm.
- x6 Washers 4.5 mm



- Wall chaser with 2 diamond discs ø125 mm.
- Adjustable cutting width with 2 diamond discs & 6 washers 4.5 mm included

- Overload control system. During a power surge, the machine switches off instantly until the safe situation returns, after 1 sec. it turns on again itself.

- Coupling for an external vacuum cleaner.
- Cutting depth regulator.
- Paddle switch.
- External carbon brush replacement.
- Soft Start

6 Different cutting widths

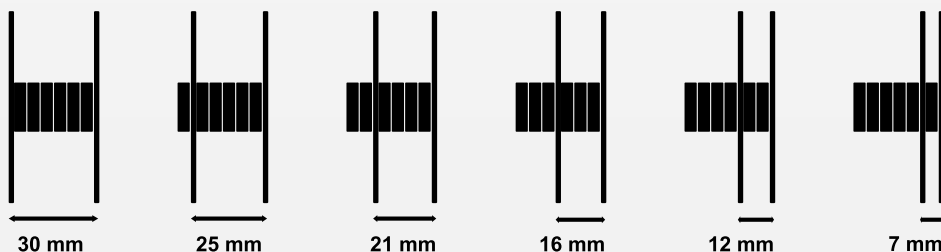

DIAMOND DISC WALL CHASER ø150 mm

CD 150 B2 K (2 Diamond discs)

Code 1.4426

CD 150 B4 K (4 Diamond discs)

Code 1.4597



Power	2400	W
No load speed	8500	rpm
Disc diameter	ø150	mm
Cutting width	7 - 35	mm
Max. cutting depth	8 - 43	mm
Weight	6	kg

Included:

- Auxiliary handle
- Support wheel
- x2 diamond discs ø150mm.
- x10 Washers 3 mm
- x1 Closing washer 20 mm
- x1 Closing washer 25 mm
- HD-PE Carry Case



- Wall chaser with 2 diamond discs ø150 mm. (Optional 4)
- Adjustable cutting width with 2 diamond discs & washers included.

- Able to use up to 4 diamond discs. 25 mm slashes with 4 discs do not require chisel, 35 mm drastically reduce the need of chisel depending on the material cut.

- Coupling for an external vacuum cleaner.
- Ready for coupling with an external vacuum cleaner.
- Cutting depth regulator.
- Paddle switch.
- External carbon brush replacement.
- Soft Start

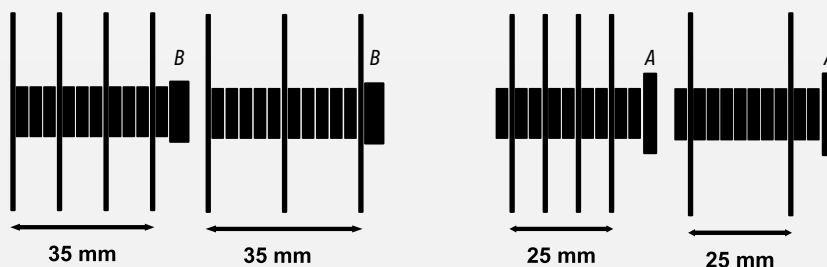

DIAMOND DISC WALL CHASER ϕ 180 mm

CD 180 K

Code 1.6007



Power	1800	W
No load speed	4100	rpm
Disc diameter	ϕ 180	mm
Cutting width	9 - 51	mm
Max. cutting depth	15 - 54	mm
Weight	7.7	kg

Included:

- Auxiliary handle
- x4 wheels
- x2 diamond discs ϕ 180 mm.
- Washers:
x2 Washers 5mm
x1 Washer 10mm
x1 Washer 12mm
x1 Washer 15mm
- HD-PE Carry Case



- Wall chaser with 2 diamond discs ϕ 180 mm.
- Adjustable cutting width with 2 diamond discs & washers included.
- 15 possible cutting configurations .
- Overload control system. During a power surge, the machine switches off instantly until the safe situation returns, after 1 sec. it turns on again itself.
- Ready for coupling with an external vacuum cleaner.
- Cutting depth regulator.
- Paddle switch.
- External carbon brush replacement.
- Soft Start
- Wheels on the base for better slashing.

MILLING CUTTER WALL CHASER

RF 1100 K

Code 1.1654



Power	1100	W
No load speed	1600	rpm
Milling cutter diameter	ϕ 78	mm
Cutting width	25	mm
Max. cutting depth	11 - 30	mm
Weight	6.5	kg

- Wall chaser with ϕ 78 mm milling cutter & Cutting width 25 mm.
- Specially meant for bricks, cell concrete, soft materials & rendered concrete.
- Ready for coupling with an external vacuum cleaner.
- Cutting depth regulator.
- Paddle switch.

Included:

- Vacuum coupling
- Milling cutter ϕ 78 mm
- HD-PE Carry Case



CIRCULAR SAW Ø125 mm

CP 125

Code 1.1565

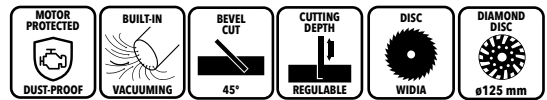

Power	1400	W
No load speed	12000	rpm
Disc diameter	Ø125 x 22.2	mm
Max. cut at 45°	34	mm
Max. cut at 90°	40	mm
Weight	3.3	kg

- Mini circular saw with great power (1400W) Compact & balanced design.

- Anti dust protection system & quality bearings.

- Suitable for all kind of Ø125 x 22.2 mm. discs. For all types of materials, from wood & laminated to porcelanic & marble.

CP 125 + Multimaterial disc (Code 1.2397)

Included:
- Lateral guide
- x1 multimaterial disc

OPTIONAL CP 125 + Diamond disc

Included:
- Lateral guide
- x1 diamond disc



CIRCULAR SAW FOR METAL & SANDWICH PANELS Ø230 mm

CM 230 K

Code 1.5977

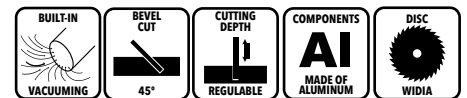

Power	1700	W
No load speed	2600	rpm
Disc diameter	Ø235 x 25.4	mm
Max. cut at 90°	84	mm
Max. cut at 45°	56	mm
Weight	7.1	kg

- Circular saw for widia discs of Ø235 mm.

- Designed for dry cutting at low speeds without refrigeration.

- Specially designed for metal & sandwich panels cutting

- Oversized base for precision cuts.

- Cutting depth regulator.

- Bevel cuts 45°.

Included:

- Cutting guide
- Widia disc Ø230 x 25.4 mm



CIRCULAR SAW WITH GUIDE ø125 mm

SCP 125 DIAMANT

Code 1.2829



Power	1400	W
No load speed	13800	rpm
Disc diameter	ø125 x 22.2	mm
Max. cut at 45°	22	mm
Max. cut at 90°	39	mm
Guide (x3 segments)	1500 x 183 x 9.5	mm
Weight	2.5-	kg

Included:

- 1.5 m. Cutting guide with 3 segments of 50 cm
- STAYER H10 disc ø125 mm.
- Hose with flow regulator & faucet coupling
- x2 Suction cups
- x2 Clamps
- Carry bag



PRCD SAFETY SWITCH

X2 SUCTION CUPS

X2 CLAMPS

- Circular saw for ceramic materials, porcelanic, natural & artificial stone.
- Aluminum cutting guide 1.5 meters (x3 segments 50 cm).
- Water cooling system.
- Power cable with normative safety switch to work with water.

CUTTING GUIDE:
0.5 meters
Code 12.888
1 Meter
Code 12.894

- Cutting depth regulator.
- Bevel cuts 45°.
- Anti sliding ergonomic handle



Included DIAMOND DISC
TURBO EXTRA FINE
PROFESSIONAL
H10 ø125 MM

WATER COOLING HOSE



1.5 M CUTTING GUIDE
X3 SECTIONS OF 50 CM

CIRCULAR SAW WITH GUIDE ø185 mm

CPT 3000 E

Code 1.1726

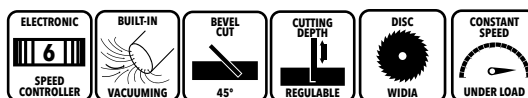

Power	1400	W
No load speed	2000 - 5000	rpm
Disc diameter	ø185 x 30	mm
Max. cut at 90°	67	mm
Max. cut at 45°	47	mm
Max. cut at 90° with guide	62	mm
Max. cut at 45° with guide	44	mm
Weight	4	kg

Included:

- 3m. guide made of (3 segments 1m)
- Widia disc ø185 x 30 mm

- Circular saw for widia discs of ø185 mm.
- Aluminum cutting guide 3 meters (3 segments of 1 meter).
- Electronic speed regulator
- Electronic system to keep constant speed under load.
- Specially suited for aluminum, wood & laminated floor.
- Ready for coupling with an external vacuum cleaner.
- Cutting depth regulator.
- Bevel cuts 45°.
- Ergonomic handles



IMMERSION CIRCULAR SAW \varnothing 165 mm

CP 165 G

Code 1.4149

Disc diameter	\varnothing 165	mm
Power	1400	W
No load speed	5200	rpm
Max. cut at 90°	56	mm
Max. cut at 45°	42	mm
Guide (x3 assemblable units)	1.5	m
Weight	5.5	kg

Compatible Guides:

Cutting guide 1.5 meter
Code 12.917

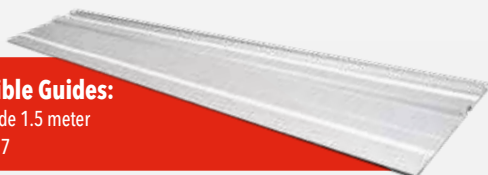

NEW
Check Availability

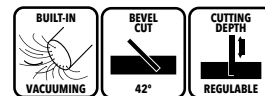

CIRCULAR SAW \varnothing 190 mm

CP 190 G

Code 1.3318

Disc diameter	\varnothing 190 x 30	mm
Power	1600	rpm
No load speed	5500	mm
Max. cut at 90°	66	mm
Max. cut at 45°	45	mm
Weight	5	kg

Compatible Guides:

Cutting guide 1.5 meter
Code 12.917

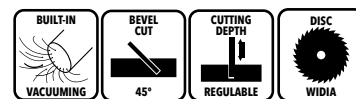
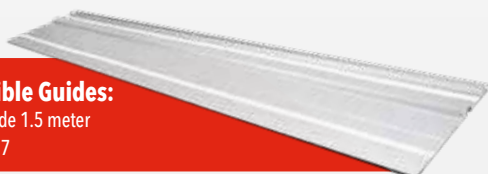

Included:

- Widia disc \varnothing 190 x 30 mm

- Circular saw for widia discs of \varnothing 190 mm.
- Aluminum cutting guide
- Specially suited for wood & laminated floors
- Ready for coupling with an external vacuum cleaner.
- Cutting depth regulator.
- Bevel cuts 45°.
- Ergonomic handles



CIRCULAR SAW \varnothing 235 mm

CP 236 G

Code 1.3319

Disc diameter	\varnothing 235 x 30	W
Power	2000	rpm
No load speed	4500	mm
Max. cut at 90°	85	mm
Max. cut at 45°	60	mm
Weight	8.8	kg

Compatible Guides:

Cutting guide 1.5 meter
Code 12.917

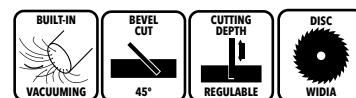
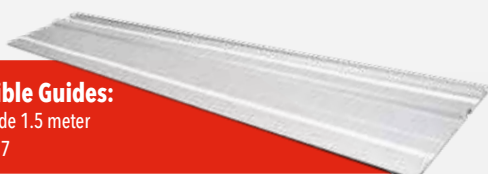

JIG SAW

S 55 CE

Code 1.4271

Power	500	W
No load speed	0 - 3000	rpm
Max. cut wood	55	mm
Max. cut steel	3	mm
Max. cut plastic	6	mm
Bevel cut	0 - 45	°
Weight	2	kg

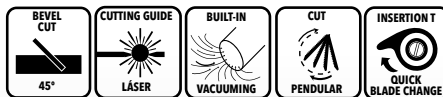

- Jig saw with powerful 500W motor.
- Electronic variator with 6 speed levels to adapt to all types of tasks and materials.
- Universal T insert with quick blade change system for a simple and fast workflow.
- Beveled cuts up to 45°.
- Prepared for connection with an external vacuum cleaner.

JIG SAW

S 90 PE

Code 1.1457

Power	800	W
No load speed	0 - 3000	rpm
Max. cut wood	100	mm
Max. cut steel	10	mm
Max. cut plastic	100	mm
Bevel cut	0 - 15 - 30 - 45	°
Weight	2.3	kg

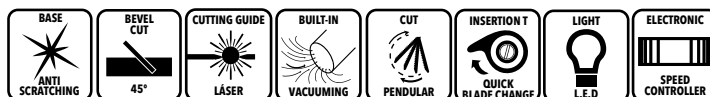

- Quick blade change. T Insertion
- Pendular cutting. 3 Positions
- 6 levels electronic speed regulator
- Ready for coupling with an external vacuum cleaner
- Laser cutting guide

Included:
- Side Cutting guide

JIG SAW

S 100 PE

Code 1.3654

Power	750	W
No load speed	600 - 2800	rpm
Max. cut wood	110	mm
Max. cut steel	10	mm
Max. cut Aluminum	20	mm
Bevel cut	0 - 15 - 30 - 45	°
Weight	3.1	kg

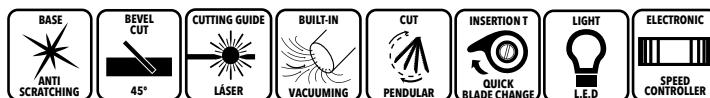

- Aluminum cast head
- Quick blade change. T Insertion
- Pendular cutting. 3 Positions
- 6 levels electronic speed regulator
- Ready for coupling with an external vacuum cleaner

Included:
- Side Cutting guide

NEW

JIG SAW

S 110 PE

Code 1.5936

Power	780	W
No load speed	0 - 3000	rpm
Max. cut wood	110	mm
Max. cut steel	8	mm
Max. cut Aluminum	100	mm
Bevel cut	0 - 15 - 30 - 45	°
Weight	2.9	kg



- Aluminum cast head
- Quick blade change. T Insertion
- Pendular cutting. 3 Positions
- 6 levels electronic speed regulator
- Ready for coupling with an external vacuum cleaner
- Laser cutting guide

Included:
- Side Cutting guide
- x2 saw blades

RECIPROCATING SAW

SS 210 B

Code 1.2765

Power	1050	W
Saws per minute	0 - 2800	spm
Saw displacement	29	mm
Max. cut wood	210	mm
Max. cut steel	20	mm
Max. cut Aluminum	30	mm
Max. cut PVC/profiles	110	mm
Weight	3.4	kg

- Quick blade change. Universal insertion
- Rotary handle
- Electronic speed regulator.
- Rubber coated housing
- Adjustable depth regulator.
- L.E.D worklight

Included:
- x1 Saw blade 150 mm.



RECIPROCATING SAW

SS 280 P

Code 1.2001

Power	1200	W
Saws per minute	800 - 2800	spm
Saw displacement	28	mm
Max. cut wood	230	mm
Max. cut steel	25	mm
Max. cut Aluminum	35	mm
Max. cut PVC/profiles	120	mm
Weight	3.7	kg

- Quick blade change. Universal insertion
- Pendular cutting. 4 Positions
- 6 levels electronic speed regulator
- Rubber coated housing
- Adjustable depth regulator
- L.E.D worklight

Included:
- x2 Saw blades

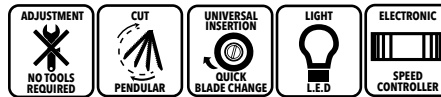

OSCILLATING MULTI TOOL

MULTI TOOL PRO 300 K

Code 1.1567

Power	300	W
No load speed	15000 - 23000	rpm
Orbit de oscilación	3.2	mm
Weight	1.5	kg

- Oscillating multi tool with quick accessory replacement.
- Flat open insertion.
- Electronic speed regulator
- Built-in vacuuming. Ready for coupling with an external vacuum cleaner.
- Great versatility: cuts & sands all kind of materials from wood & metals to porcelanic. Also suitable for paint scrapping & carpets.

Included:
- Hose
- Self adhering sanding sheets
- Self adhering delta plate
- Semicircular saw HCS
- Die saw HCS
- Scraper
- HD - PE Carry Case



ORBITAL SANDER WITH 3 PLATES

LOM 130 3P

Code 1.2543

Power	190	W
No load speed	11000	rpm
Orbit	2	mm
Weight	1.3	kg

- Compact sander for **wood & drywall**.
- Designed to be used single-handedly.
- Suitable for damp sanding.
- Rubber coated head to reduce vibrations.
- Dust protection between the plate and the motor
- Double sanding sheet holding system: **Self adhering plate & clamps**
- Ready for coupling with an external vacuum cleaner.
- Unique model, **capable to double face sanding**.
- Specially designed for wood blinds sanding

Included:

- Dust collecting bag.
- Rectangular plate 85 x 135 mm.
- Double face plate 85 x 200 m / 85 x 60 mm.
- Delta plate 89 x 225 mm.
- x11 Rectangular sanding sheets 85 x 135 mm.
x2 P40 / x3 P60 / x4 P80 / x2 P120
- x11 Delta sanding sheets 90 x 225 mm.
x2 P40 / x3 P60 / x4 P80 / x2 P120
- x11 Double face Sanding sheets 80 / 85 x 255 / 260 mm.
x2 P40 / x3 P60 / x4 P80 / x2 P120



Ergonomic Rubber head

Ready for Dust extraction

Clamps

x3 Self adhering plates
x33 Sanding sheets included

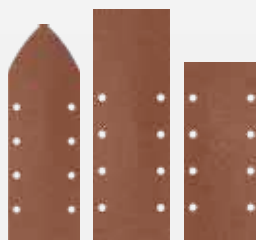

Included
X33 Sanding sheets

ORBITAL SANDER

DELTA 150

Code 1.2374



Power	150	W
No load speed	14000	rpm
Plate size	150 x 150 x 100	mm
Weight	0.9	kg

- Single handed delta sander
- Anti vibration system.
- Built-in dust collection tank
- Self adhering plate

Included:

- Split sanding delta sheets
x2 P60 / x2 P80 / x2 P120

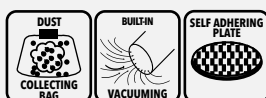

LOM 180

Code 1.2553



Power	260	W
No load speed	12000	rpm
Plate size	90 x 185	mm
Orbit	2	mm
Weight	1.7	kg

- Aluminum base.
- Clamps for no adherent sandpapers
- Built-in dust collection tank
- Self adhering plate
- Ergonomic design

Included:

- x1 Sanding sheet.

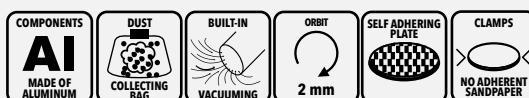

LOM 230

Code 1.2135



Power	400	W
No load speed	12000	rpm
Plate size	115 x 230	mm
Orbit	2	mm
Weight	2.9	kg

- Powerful S1 constant service motor.
- Clamps for no adherent sandpapers
- Built-in dust collection bag
- Self adhering plate
- Ergonomic design with reduced vibrations

Included:

- x2 Sanding sheets P80.

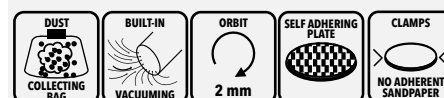

ROTORBITAL SANDER

RO 125

Code 1.2404

Power	300	W
No load speed	4000 - 12000	rpm
Plate size	ø125	mm
Orbit	2.8	mm
Weight	1.4	kg

- 6 levels electronic speed regulator
- Self adhering plate
- Low vibration

Included:

- Auxiliary lateral handle.
- Dust collecting bag.
- Sanding disc

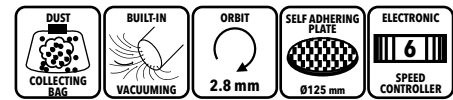

ROTORBITAL SANDER

RO 150 E

Code 1.638

Power	450	W
No load speed	4000 - 13000	rpm
Plate size	ø150	mm
Orbit	2.5	mm
Weight	2.4	kg

- 5 levels electronic speed regulator
- Self adhering plate

Included:

- Auxiliary lateral handle.
- Dust collecting bag.
- Sanding disc

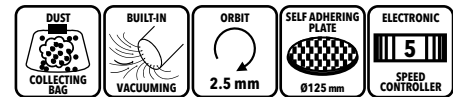

ROTORBITAL SANDER

RO 150 X5

Code 1.4144

Power	450	W
No load speed	4000 - 10000	rpm
Plate size	ø150	mm
Orbit	5	mm
Weight	2	kg

- Electronic variable speed with 6 settings.
- Powerful 450 W motor for intensive sanding on all surfaces: wood, metal, and stone.
- 150 mm backing pad with 16 holes for optimal dust extraction.

Included:

- 1 dust bag
- 4 sandpapers
- 1 wrench
- Set of brushes
- 1 suction adapter

NEW

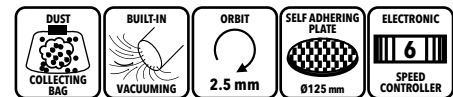

ROTORBITAL SANDER BRUSHLESS MOTOR

RO 5.0 B BRUSHLESS

Code 1.3623

Power	400	W
No load speed	4000 - 10000	rpm
Plate size	ø150	mm
Orbit	5	mm
Weight	1.28	kg

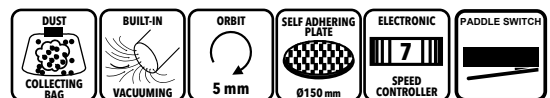
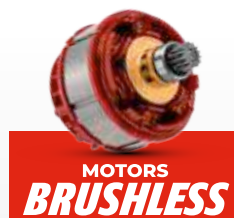

- **Powerful brushless** 400 W motor that increases the tool's lifespan while enhancing its power.
- Suitable for woodworking, bodywork, Corian counters.
- **Self adhering plate 150 mm with 15 holes** for an optimal vacuuming.
- **Paddle switch** with anti sliding handle
- Symetric structure, allows to use the tool with both hands.

- **7 levels speed regulator** : 4000/ 5000/ 6000/ 7000/ 8000/ 9000 y 10.000rpm.
- **Tacometer to keep the tool's power constant under heavy duty.**



BELT SANDER

LEN 610

Code 1.5636



Power	1200	W
No load speed	500	rpm
Belt size	100 x 610	mm
Sanding surface	100 x 155	mm
Weight	2.3	kg

- Belt sander with powerful belt transmission motor.

- Powerful Built-in vacuuming system.
- Ready for coupling with an external vacuum cleaner.
- Aluminum structure.
- Double handles for safe sanding.
- Quick and easy sanding belt replacement.

Included:

- x1 Sanding belt P80
- Vacuum coupling
- Dust collecting bag



PLANER

P 910

Code 1.5565

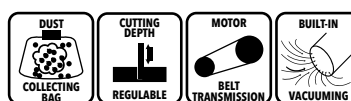

Power	900	W
No load speed	1300	rpm
Routing depth	0 - 3	mm
Depth levels	14	
Planing width	82	mm
Weight	2.8	kg

- Powerful planer with powerful belt transmission motor

- **Depth regulator by millimeter quarters**
- Powerful Built-in vacuuming system.
- Ready for coupling with an external vacuum cleaner.
- Quick blade change

Included:

- Lateral guide
- Dust collecting bag
- Blade set



BISCUIT JOINTER

BJ 120 B

Code 1.2691



Power	900	W
No load speed	11000	rpm
Max. routing	13 x 4	mm
Biscuits	0 - 10 - 20	n°
Milling cutter size	ø100 x 4 x 22	mm
Tilted cut	0 - 90°	mm
Max. work height	35	mm
Weight	3.2	kg

- Biscuit jointer for wood panels.

- **Specially designed for marquetry & cabinetry**
- Ready for n° 0, n° 10 & n°20 biscuits
- Routing 45° and up to 35 mm height

Included:

- Milling cutter
- Dust collecting bag



HINGE ROUTER

PRP 6

Code 1.2141

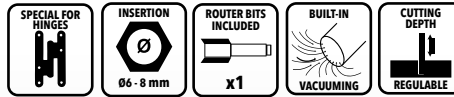

Power	480	W
No load speed	27000	rpm
Collet	ø6 - ø8	mm
Routing depth	0 - 30	mm
Weight	1.6	kg

- **Light router specially designed for hinge placing on wood profiles and doors .**

- Millimetric guide with depth regulator for maximum routing control.
- Ready for coupling with an external vacuum cleaner.
- Quick router bit replacement.

Included:

- x1 die router bit ø14 mm
- Vacuum coupling
- Lateral guide



ROUTER

PR 6

Code 1.653

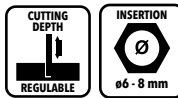

Power	550	W
No load speed	32000	rpm
Collet	ø6	mm
Routing depth	0 - 40	mm
Weight	1.8	kg

- **Lightweight router.**

- Millimetric guide with depth regulator for maximum routing control.
- Adjustable lateral guide.
- External carbon brush replacement.

Included:

- Lateral guide
- Precision guide for curved routing



ROUTER

PR 10 EK

Code 1.1310



Power	1800	W
No load speed	8000 - 30000	rpm
Collet	ø6 / 6.3 / 8 / 12 / 12.7	mm
Routing depth	0 - 60	mm
Weight	4	kg

- **Double handle router for router bits from ø6 mm up to ø12.7 mm.**

- **6 levels electronic speed regulator**

- Millimetric guide with depth regulator for maximum routing control.
- Turret system for flattening irregular surfaces.
- Ready for template routing
- Ready for coupling with an external vacuum cleaner.

Included:

- x6 Router bits
- x6 Clamps ø6 / 6.3 / 8 / 12 / 12.7 mm.
- Lateral guide
- Template platform
- HD-PE Carry Case



POLISHER

RP 15-125

Code 1.3646



Power	780	W
No load speed	2200 - 5000	rpm
Disc diameter	125	mm
Orbit	15	mm
Spindle thread	M14	
Weight	3.1	kg

Self adhering plate 120 mm.
Code 12.1170



POLISHER

RP 21 - 150

Code 1.3647



Power	1000	W
No load speed	2200 - 4500	rpm
Disc diameter	150	mm
Orbit	21	mm
Spindle thread	M14	
Weight	3.1	kg

Self adhering plate 150 mm.
Code 12.1171



POLISHER

LU 260 CE

Code 1.1931



Power	1200	W
No load speed	600 - 3200	rpm
Plate size	Ø180	mm
Insertion	M14	
Weight	3	kg

- Self adhering plate Ø180 mm.
- Constant speed electronic system under load
- 6 levels electronic speed regulator
- Specially suited for metal sanding & polishing
- Adjustable auxiliary handle.
- Ergonomic rear handle
- External carbon brush replacement.

Included:

- Self adhering plate
- Wool pad

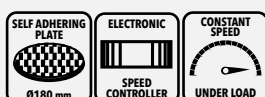

POLISHER

PL 2500 E

Code 1.5678



Power	800	W
No load speed	800 / 1200 - 4000	rpm
Plate size	Ø170	mm
Insertion	M14	
Weight	2.3	kg

- Polisher with self adhering plate Ø170 mm.
- Constant speed electronic system under load
- 5 levels electronic speed regulator
- 2 Mechanical speeds to adapt to all kind of jobs
- Vertical motor to reach narrow areas.
- Specially suited for metal sanding & polishing
- External carbon brush replacement.
- Soft Start
- Plate lock against unintentional activations.

Included:

- Self adhering plate
- Wool pad

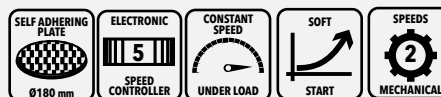

DRUM SANDER

LS 1200 B

Code 1.2010



Power	1300	W
No load speed	900 - 3000	rpm
Max roll diameter	ø100 - 125	mm
Max roll width	100	mm
Spindle	M8	
Weight	4.6	kg

- Drum sander with S1 constant service motor for rolls ø100 - 125 mm
- Constant speed under load
- 6 levels electronic speed regulator.
- External carbon brush replacement.
- Soft Start
- Spindle lock for easy roll replacement
- Specially suited for rust removal, sanding, polishing on metals as well as wood structuring.

Included:
- Auxiliary handle

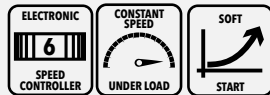

PIPE SANDER

LT 1401 EK

Code 1.1368



Power	1400	W
No load speed	750 - 3000	rpm
Belt speed	2.7 - 8.5	m/s
Belt size	40 x 760	mm
Weight	3.7	kg

- Powerful sander with S1 constant service motor
- Constant speed electronic system under load
- 6 levels electronic speed regulator
- Wide sanding arc 270°. For pipes up to ø180 mm.
- High stability pulleys with double bearings.
- Sanding belt quick replacement with no tools

- Adjustable belt tension
- Soft Start

Included:
- Auxiliary handle
- Aluminum carry case
- x9 Sanding belts 40 x 760 mm (x3 P60 / x3 P120 / x3 P240)



BLOWER

SP 700

Code 1.2409



Power	480	W
No load speed	0 - 16000	rpm
Air flow	3	m³
Weight	1.6	kg

- Lightweight blower for dust, leaves and workshop cleaning.
- Cable 2m.
- Flexible pipe.
- Ergonomic handle
- Trigger interlock for extender tasks.

SOLIDS & LIQUIDS VACUUM CLEANER / BLOWER

BVAC 1420

Code 1.3648



Power	1400	W
Socket power output	2000	W
Suction capacity	16.5	Kpa
Tank capacity	20	L
Telescopic tube	35	mm
Air flow	1.9	m³/min
Cable	3.5	m
Weight	4.6	kg

- Light blower for cleaning leaves, dust and sawdust in gardens and workshops.
- Cable 3m.
- Flexible blowing tube.
- Ergonomic handle
- Motor lock for prolonged work.
- Hose 1.5m with tube 2.5m.

SOLIDS & LIQUIDS VACUUM CLEANER

VAC 2030

Code 1.1690

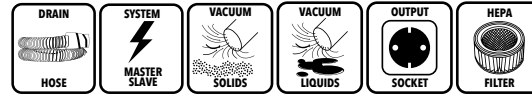

Power	1200	W
Output socket power	2000	W
Suction capacity	17	Kpa
Tank capacity	30	L
Hose dimensions	ø38 x 1500	mm
Telescopic tube	40 - 80	cm
Cable	4.5	m
Weight	11	kg

- Included:**
- Flexible hose
 - Vacuum coupling
 - Telescopic tube
 - 2 Positions brush
 - Flat nozzle
 - Round brush
 - Dust bag
 - Washable filter bag
 - Sponge filter



- Output socket to connect a tool to the vacuum cleaner.

keeps working for 8 seconds to completely remove dust.

Activating the connected tool activates the vacuum cleaner simultaneously. When the tool is stopped the vacuum

- Soft Start.
- 4 Wheels

SOLIDS & LIQUIDS VACUUM CLEANER

VAC 2050 C

Code 1.1198

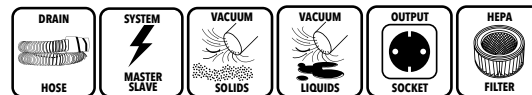

Power	1200	W
Output socket power	2000	W
Suction capacity	17	Kpa
Tank capacity	50	L
Hose dimensions	ø38 x 1900	mm
Telescopic tube	40 - 80	cm
Cable	4.5	m
Weight	11	kg

- Included:**
- Flexible hose
 - Vacuum coupling
 - Telescopic tube
 - 2 Positions brush
 - Flat nozzle
 - Round brush
 - Dust bag
 - HEPA Filter
 - Anti-static chain



- Solids & Liquids vacuum cleaner.
 - VAC 2050 C Includes an HEPA Filter, Draining hose & greater tank capacity.
 - Output socket to connect a tool to the vacuum cleaner.
 Activating the connected tool activates the vacuum cleaner simultaneously.

When the tool is stopped the vacuum keeps working for 8 seconds to completely remove dust.

- Soft Start.
- 4 Wheels

SOLIDS & LIQUIDS VACUUM CLEANER / BLOWER

VAC 2030 V-SYSTEM

Code 1.3439

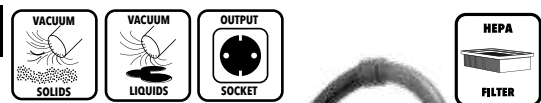

Power	1600	W
Output socket power	2000	W
Suction capacity	20	Kpa
Tank capacity	30	L
Hose dimensions	Ø32 x 2000	mm
Telescopic tube	40-80	cm
Cable	4	m
Weight	11	kg

Large rectangular HEPA filter for greater protection of the motor.

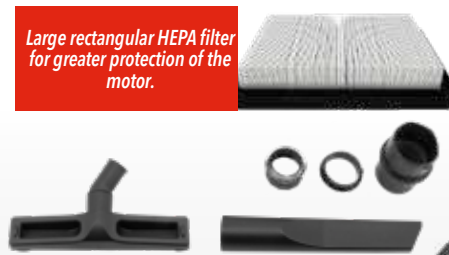

- Included:**
- Long square brush (for wet and dry) - 32mm.
 - Small nozzle 32 mm.
 - Circular nozzle 32 mm.
 - Pair of small front wheels.
 - Pair of large rear wheels.
 - Telescopic metal tube-32mm.



- Solids & Liquids vacuum cleaner.
 - HEPA Filter cleaning button blocking the nozzle.
 - Output power socket to switch tools.

- Integrated blower.
- Full container indicator.
- Integrated accessory storage system.
- 4 wheels.

SOLIDS & LIQUIDS VACUUM CLEANER

BVAC 2240 V-SYSTEM

Code 1.3768

BVAC 2240 AIR V-SYSTEM

Code 1.3769

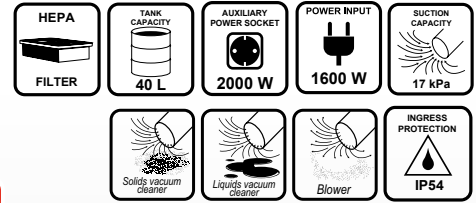

BVAC 2240 V-SYSTEM **BVAC 2240 AIR V-SYSTEM**

Power	1600	1600	W
Output socket power	2000	2000	W
Suction capacity	20	20	KPa
Tank capacity	40	40	L
Hose dimensions	Ø32 x 2000	Ø32 x 2000	mm
Cable	5	5	m
Weight	6	6	kg



INCLUDED ACCESSORIES



Large rectangular HEPA filter for greater protection of the motor.



SOLIDS & LIQUIDS VACUUM CLEANER

BVAC 2400 DM

Code 1.2412



Power	1200 - 2400	W
Output socket power	2000	W
Suction capacity	23	Kpa
Tank capacity	60	L
Hose dimensions	ø38 x 4000	mm
Cable	4.5	m
Weight	23	kg

**DOUBLE ENGINE
MAXIMUM POWER**



- Solids & Liquids vacuum cleaner with 2 independent motors of 1200W each one.
- HEPA Filter cleaning button blocking the nozzle.
- Output socket power to switch tools. The tool & the vacuum cleaner must be activated separately.
- Internal buoy to control the tank level.
- Draining hose built-in the tank.
- 4 Wheels.
- Class protection IPX4

- Included:**
- Flexible hose
 - Vacuum coupling
 - Metal 2 pieces tube
 - Bristle brush (for carpets)
 - Floor brush (for liquids).
 - Flat nozzle
 - Round brush
 - HEPA Filter



MITRE SAWS

WOOD • METAL • CONSTRUCTION

Professional **STAYER** miter saws

For angled and cross cuts in materials such as wood.
Designed to deliver maximum power and safety.

COMBINED MITRE SAW \varnothing 210 mm

SC 210 BW

Code 1.2003

Power	1200	W
No load speed	4500	rpm
Disc diameter	\varnothing 210 x 30	mm
Weight	12	kg

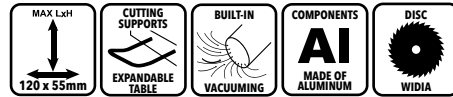
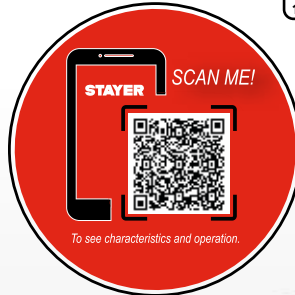

Cutting capacity: Max. Length x Max. Height (LxH)

Straight 90°	Mitre 45/90°	Bevel 90/45°	Compound -45/45°	Upper Table
120 x 55mm	65 x 55 mm	120 x 35 mm	40 x 23 mm	0-33 mm

- Mitre saw with upper saw table for widia discs of \varnothing 210 mm.
- Single-phase motor 1200W.
- Aluminum tough design.
- Rotary table with angle presets at every 5°
- Scaled cutting guide

- Included:**
- Widia disc TCT \varnothing 210 x 30 mm
 - Expandable cutting supports.
 - Parallel upper guide.
 - Disc protector.
 - Vertical clamp
 - Dust collecting bag



MITRE SAW BENCH

T100C

Code 1.2889

TABLE ADJUSTABLE HEIGHT	MAX SUPPORTED SURFACE	MAX SUPPORTED WEIGHT	WEIGHT
825 - 935 mm	68 x 37 cm	150 kg	10 kg

High quality aluminum structure ideal for all project needs. Ergonomic lever quick clamps to fix the legs, work piece quick release mechanism.

Suitable for:

- SC 210 BW
- SC 250 CW
- SC 250 W PRO
- SC 265 W
- SC 2600 W
- SC 251 NW
- SC 305 CW
- SC 305 W



COMBINED MITRE SAW \varnothing 250 mm

SC 250 CW

Code 1.2943

Power	1800	W
No load speed	4800	rpm
Disc diameter	\varnothing 250 x 30	mm
Weight	16	kg

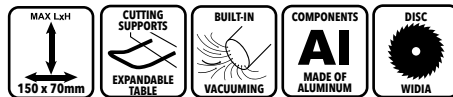

Cutting capacity: Max. Length x Max. Height (LxH)

Straight 90°	Mitre 45/90°	Bevel 90/45°	Compound -45/45°	Upper Table
150 x 70 mm	110 x 70 mm	150 x 40 mm	110 x 40 mm	0 - 38 mm

- Combined mitre saw with upper saw table for widia discs of \varnothing 250 mm.
- Single-phase motor 1800W.
- Aluminum design.
- Rotary table with angle presets at every 5°
- Scaled cutting guide

- Included:**
- Widia disc TCT \varnothing 250 x 30 mm
 - Expandable cutting supports.
 - Parallel upper guide.
 - Disc protector.
 - Vertical clamp
 - Dust collecting bag



COMBINED MITRE SAW ø250 mm

SC 250 W PRO

Code 1.1377

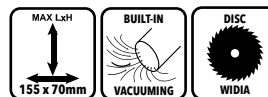

Power	1500	W
No load speed	3800	rpm
Disc diameter	ø254 x 30	mm
Weight	14.5	kg

Cutting capacity: Max. Length x Max. Height (LxH)

Straight	Mitre	Bevel	Compound	Upper Table
90°	45/90°	90/45°	-45/45°	
155 x 70mm	105 x 70 mm	150 x 50 mm	55 x 50 mm	0-43 mm

- Mitre saw with upper saw table for widia discs of ø254 mm.
- Single-phase motor 1500W.
- Rotary table with angle presets at: -45°, -22.5°, 0°, +22.5°, +45°

- Cutting length stop guide.
- Parallel upper guide.
- Goniometer for upper table.
- Lower disc cover

Included:

- Widia disc TCT ø254 x 30 mm



Maximum load	150	Kg
Dimensions	19.85 x 6.40 x 9.35.	cm
Adjustable height	825-935	mm
Adjustable width	940-1985	mm
Maximum support surface	710 x 510	mm
Weight	9.8	Kg

COMBINED MITRE SAW ø250 mm

SC 265 W

Code 1.105



Power	1500	W
No load speed	3800	rpm
Disc diameter	ø254 x 30	mm
Weight	15.5	kg

Cutting capacity: Max. Length x Max. Height (LxH)

Straight	Mitre	Bevel	Compound	Upper Table
90°	45/90°	90/45°	-45/45°	
155 x 70mm	105 x 70 mm	150 x 20 mm	55 x 50 mm	0-43 mm

- Mitre saw with upper saw table for widia discs of ø254 mm.
- Aluminum cast table
- Single-phase motor 1500W.
- Aluminum base & upper table.
- Rotary table with angle presets at: -45°, -22.5°, 0°, +22.5°, +45°

Included:

- Widia disc TCT ø254 x 30 mm
- Length regulator.
- Parallel upper guide.
- Upper table goniometer.
- Disc protector
- Dust collecting bag



COMBINED MITRE SAW ø250 mm

SC 2600 W

Code 1.1760

Power	1900	W
No load speed	2900	rpm
Disc diameter	ø250 x 30	mm
Weight	16.5	kg

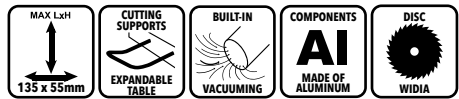

Cutting capacity: Max. Length x Max. Height (LxH)

Straight	Mitre	Bevel	Compound	Upper Table
90°	45/90°	90/45°	-45/45°	
135 x 55mm	90 x 55 mm	125 x 45 mm	65 x 45 mm	0-45 mm

- Mitre saw with upper saw table for widia discs of ø250 mm.

- Cast aluminum tough design with 3.2 mm. thickness
- Reinforced snode built in a single piece not attached to the base.
- Rotary table with angle presets at every 5°
- Adjustable upper table height.

Included:

- Widia disc TCT ø250 x 30 mm
- Expandable cutting supports.
- Parallel upper guide.
- Disc protector.
- Vertical clamp
- Dust collecting bag

MITRE SAW BENCH

T100C

Code 1.2889

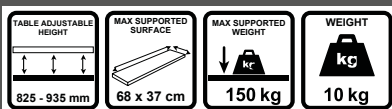

High quality aluminum structure ideal for all project needs. Ergonomic lever quick clamps to fix the legs, work piece quick release mechanism.

Suitable for:

- SC 210 CW
- SC 250 CW
- SC 250 W PRO
- SC 265 W
- SC 2600 W
- SC 251 NW
- SC 305 CW
- SC 305 W



COMBINED MITRE SAW WITH LASER ø250 mm

SC 251 NW

Code 1.2579

Power	1800	W
No load speed	5000	rpm
Disc diameter	ø250 x 30	mm
Weight	16.5	kg

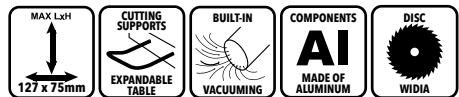

Cutting capacity: Max. Length x Max. Height (LxH)

Straight	Mitre	Bevel	Compound	Upper Table
90°	45/90°	90/45°	-45/45°	
127 x 75mm	90 x 75 mm	127 x 50 mm	85 x 50 mm	52 mm

- Mitre saw with upper saw table for widia discs of ø250 mm.

- Max cutting capacity thank to the motor position.
- Single-phase motor 1800W.
- Cast aluminum tough design.
- Rotary table with angle presets at every 5°
- Scaled cutting guide
- With laser cutting marker.

Included:

- Widia disc TCT ø250 x 30 mm
- Expandable cutting supports.
- Parallel upper guide.
- Disc protector.
- Vertical clamp
- Dust collecting bag



COMBINED MITRE SAW ø300 mm

SC 305 CW

Code 1.2944

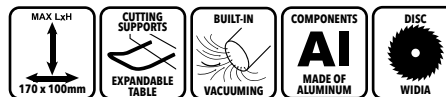

Power	1800	W
No load speed	4800	rpm
Disc diameter	ø300 x 30	mm
Weight	20	kg

Cutting capacity: Max. Length x Max. Height (LxH)

Straight	Mitre	Bevel	Compound	Upper Table
90°	45/90°	90/45°	-45/45°	
170 x 100mm	118 x 100 mm	170 x 67 mm	118 x 62 mm	50 mm

- Mitre saw with upper saw table for widia discs of ø300 mm.
- Max. cutting precision.
- Aluminum base & upper table.
- Rotary table with angle presets at every 5°
- Adjustable upper table height.

- Included:**
- Widia disc TCT ø300 x 30 mm
 - Length regulator.
 - Parallel upper guide.
 - Disc protector.
 - Vertical clamp
 - Dust collecting bag

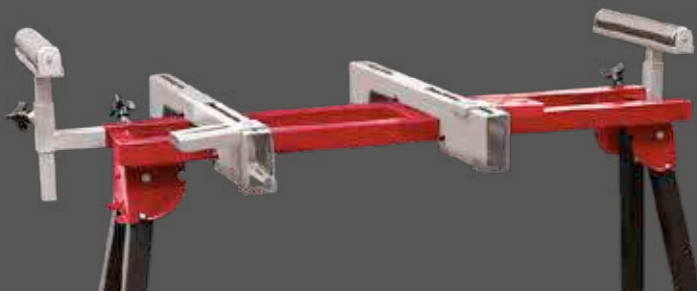

Maximum load	150	Kg
Dimensions	19.85 x 6.40 x 9.35.	cm
Adjustable height	825-935	mm
Adjustable width	940-1985	mm
Maximum support surface	710 x 510	mm
Weight	9.8	Kg

COMBINED MITRE SAW ø300 mm

SC 305 W

Code 1.2578

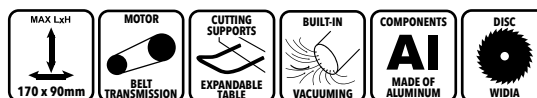

Power	1600	W
No load speed	3000	rpm
Disc diameter	ø300 x 30	mm
Weight	26	kg

Cutting capacity: Max. Length x Max. Height (LxH)

Straight	Mitre	Bevel	Compound	Upper Table
90°	45/90°	90/45°	-45/45°	
170 x 90mm	110 x 90 mm	170 x 60 mm	55 x 70 mm	0-50 mm

- Mitre saw with upper saw table for widia discs of ø300 mm.
- Max. cutting precision.
- Belt transmission on both models.
- Reduced noise.
- Aluminum base & upper table.
- Great size table 476 x 326 mm.
- Rotary table with angle presets at every 5°
- Adjustable upper table height.

- Included:**
- Widia disc TCT ø300 x 30 mm
 - Length regulator.
 - Parallel upper guide.
 - Disc protector.
 - Vertical clamp
 - Dust collecting bag



**Belt transmission
Silent motor**



TELESCOPIC MITRE SAW \varnothing 216 mm

SCR 216 W

Code 1.2183

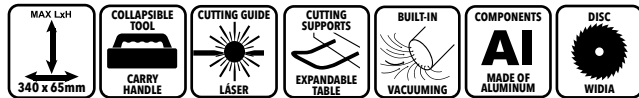

Power	1700	W
No load speed	4700	rpm
Disc diameter	\varnothing 210 / 216 x 30	mm
Weight	12	kg

Cutting capacity: Max. Length x Max. Height (LxH)

Straight	Mitre	Bevel	Compound
90°	45/90°	90/45°	-45/45°
340 x 65 mm	240 x 65 mm	340 x 40 mm	240 x 40 mm

- Telescopic mitre saw for widia discs of \varnothing 216 mm.
- Sliding head for great length cuts.
- Laser cutting guide
- Base made of aluminum.
- Rotary table with angle presets at:
-45° / -30° / -22.5° -15° / 0° / +15° / +22.5° / +30° / +45°

- Included:**
- Widia disc TCT \varnothing 210 x 30 mm
 - Expandable cutting supports.
 - Vertical clamp
 - Dust collecting bag



TELESCOPIC MITRE SAW \varnothing 255 mm

SCR 255 CW

Code 1.1676

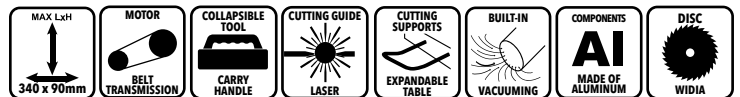

Power	1800	W
No load speed	6000	rpm
Disc diameter	\varnothing 255 x 30	mm
Weight	17.5	kg

Cutting capacity: Max. Length x Max. Height (LxH)

Straight	Mitre	Bevel	Compound
90°	45/90°	90/45°	-45/45°
340 x 90 mm	240 x 90 mm	340 x 50 mm	240 x 45 mm

- Telescopic mitre saw for widia discs of \varnothing 255 mm.
- Sliding head for great length cuts.
- Belt transmission silent motor
- Laser cutting guide
- Base made of aluminum.
- Rotary table with angle presets at:
-45° / -30° / -22.5° -15° / 0° / +15° / +22.5° / +30° / +45°

- Included:**
- Widia disc TCT \varnothing 255 x 30 mm
 - Expandable cutting supports.
 - Vertical clamp
 - Dust collecting bag



**Belt transmission
Silent motor**

TELESCOPIC MITRE SAW \varnothing 315 mm

SCR 315 W

Code 1.1933

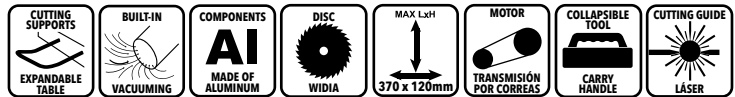

Power	1800	W
No load speed	3500	rpm
Disc diameter	\varnothing 315 x 30	mm
Weight	19	kg

Cutting capacity: Max. Length x Max. Height (LxH)

Straight 90°	Mitre 45/90°	Bevel 90/45°	Combined -45/45°	Combined Right.
370x105 mm 330x120 mm	370x65 mm 370x35 mm	255x105 mm	255x65 mm	255x35 mm

- Telescopic mitre saw for widia discs of \varnothing 315 mm.
- Tilttable head rightwards and leftwards
- 120 mm max cutting height.
- Sliding head for great length cuts.
- Belt transmission silent motor
- Laser cutting guide
- Base made of aluminum.
- Scaled cutting guide for mayor exactitud
- Rotary table with angle presets at:
-45° / -30° / -22.5° -15° / 0° / +15° / +22.5° / +30° / +45°

Included:

- Widia disc TCT \varnothing 315 x 30 mm
- Expandable cutting supports.
- Vertical clamp
- Dust collecting bag

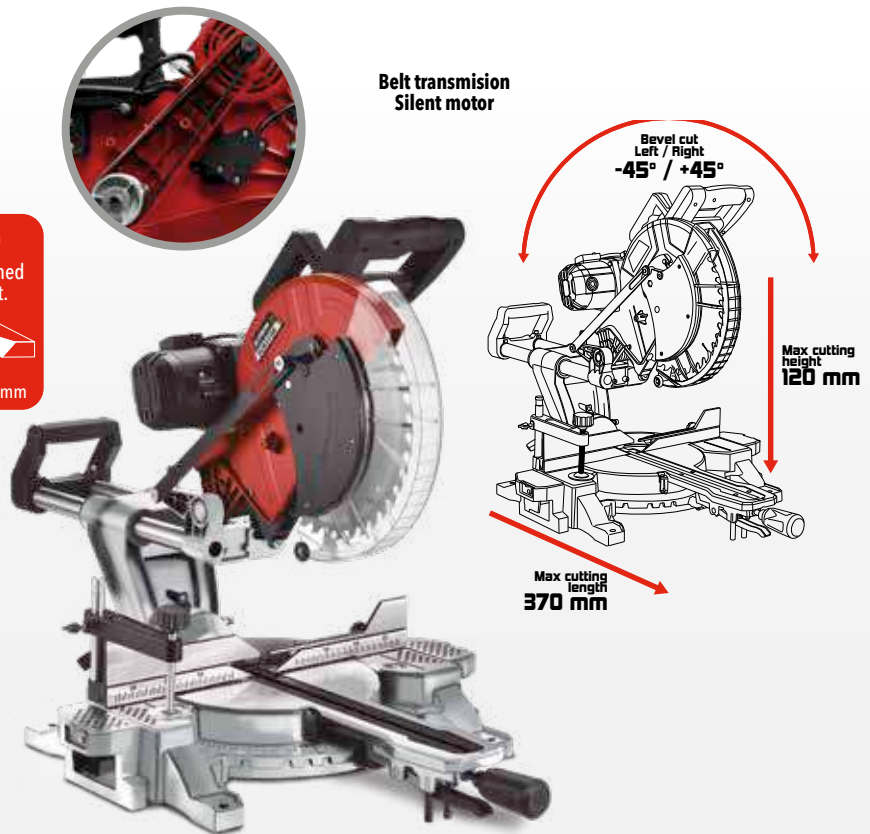

ABRASIVE DISC CHOP SAW \varnothing 355 mm

TV 509 D

Code 1.1976

Power	2400	W
No load speed	4000	rpm
Disc diameter	\varnothing 355 x 25.4	mm
Weight	17	kg

Cutting capacity

Cuts at 90°	Profile	Width	Height
(profile & solid)		\varnothing 120	mm
		115 x 115	mm
		120 x 120	mm
		210 x 85	mm
Cuts at 45°	Profile	Width	Height
(profile & solid)		\varnothing 120	mm
		100 x 100	mm
		100 x 100	mm
		130 x 100	mm

- Metal chop saw with abrasive discs.
- Adjustable horizontal clamp -15° to +45° built-in.
- Single-phase motor
- Adjustable depth regulator
- Bevel cuts 0° a -45°
- Foldable for transport & storage

Included:

- Iron cutting abrasive disc \varnothing 355 x 3.0 x 25.4 mm (Code 5.511)

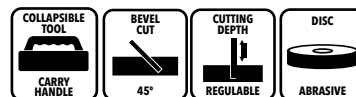

WIDIA DISC CHOP SAW \varnothing 185 mm

TD 185 (BRUSHLESS)

Code 1.3320

Power	1500	W
No load speed	1900 / 2300 / 2800	rpm
Disc diameter	\varnothing 185	mm
Weight	11	kg

Cutting capacity

Cuts at 90°	●	\varnothing 55	mm
(profile & solid)	■	45 x 45	mm
	└	35 x 85	mm

Cuts at 45°	●	\varnothing 45	mm
(profile & solid)	■	40 x 40	mm
	└	30 x 80	mm

- **Brushless motor**: High torque and stable speed.
- **Powerful brushless motor** for increased efficiency, significantly reducing heat build-up and considerably increasing motor life and battery life.
- **Cutting-off machine for fast and clean cutting of metals.**
- **Hardened steel base.**
- **Soft start**
- **Constant speed**
- **Aluminum cutting.**

- **Protection against disconnection (anti-rearming) and overload.**
- **Power on and overload indicator.**
- **3 speeds:**
 1900 rpm: Ferrous metals.
 2300 rpm: Non-ferrous metals
 2800 rpm: Stainless steel

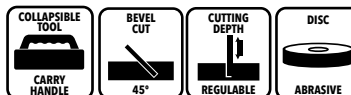

Included:
 - Widia disc TCG \varnothing 185x25.4 mm
 Code: 12.931



WIDIA DISC CHOP SAW \varnothing 355 mm

TD 355 B

Code 1.2507

Power	2200	W
No load speed	1500	rpm
Disc diameter	\varnothing 355 x 25.4	mm
Weight	22	kg

Cutting capacity

Cuts at 90°	●	\varnothing 130	mm
(profile & solid)	■	120 x 120	mm
	└	120 x 120	mm
	■	185 x 95	mm

Cuts at 45°	●	\varnothing 120	mm
(profile & solid)	■	90 x 90	mm
	└	90 x 90	mm
	■	105 x 90	mm

- **Chop saw with widia discs TCG.**
 - **Adjustable horizontal clamp -15° to +45° built-in.**
 - **Single-phase motor.**
 - Iron cast base
 - Adjustable depth regulator
 - Bevel cuts 0° a -45°
 - Foldable for transport & storage
- Included:**
- Widia disc TCG \varnothing 355 x 3 x 25.4 mm (Code 12.660)

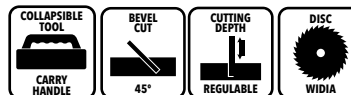

BAND SAW

SN 1435 B

Code 1.1460



Power	1/2	HP
No load speed	2000 - 4000	rpm
Blade size	1435 x 12.7 x 0.65	mm
Speed	38/80	m/min
Weight	21	kg

Cutting capacity

Cuts at 90°	●	ø125	mm
(profile & solid)	■	125 x 125	mm
	■	35 x 85	mm

Cuts at 45°	●	ø80	mm
(profile & solid)	■	80 x 80	mm
	■	80 x 100	mm

Cuts at 60°	●	ø45	mm
(profile & solid)	■	45 x 45	mm
	■	45 x 60	mm

- **Powerful band saw.**
 - **2 Speed levels.**
 - **Quick iron cast clamp 125 mm.**
 - Quick iron cast clamp 125 mm.
 - Cast aluminum arc. Steel base.
 - Length regulator.
 - Bevel cuts 0° to 60°
 - Adjustable blade tension.
- Foldable for transport & storage.

Included:
- *Bimetal saw blade*



BAND SAW

SN 1735

Code 1.5882

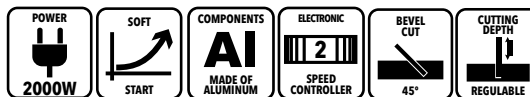

Power	2000	W
Blade size	1735 x 13 x 0.65	mm
Speed	30 - 80	n/min
Weight	38	kg

Cutting capacity

Cuts at 90°	●	ø155	mm
(profile & solid)	■	155 x 155	mm
	■	35 x 85	mm

Cuts at 45°	●	ø110	mm
(profile & solid)	■	110 x 110	mm
	■	120 x 100	mm

- **Band saw with powerful Single-phase motor.**
 - **Quick clamp 165 mm.**
 - **2 Speed levels.**
 - Soft Start.
 - Arc & base made of cast aluminum.
 - Saw tension wheel.
- Foldable for transport & storage.

Included:
- *Bimetal saw blade*

OPTIONAL:
- *Bench 57 x 46 x 80 cm*
- *Weight 16 kg*
- *Code 1.454*





GREEN LINE

Semi-professional tools designed to guarantee professional finishes with the best value for money, without compromising on innovation or reliability in tasks of varying difficulty.

The Stayer DIY tool line includes all types of cordless tools, drills, electric hammers, angle grinders, woodworking machines, miter saws, multi-tools, bench grinders, as well as tools for miscellaneous tasks and garden work.



GREEN LINE

These products are designed for the semi-professional sector, suitable for professionals, beginners, and DIY enthusiasts alike. Efficient tools with an unbeatable value for money.

MITRE SAW

SC 250 W

Code 1.589

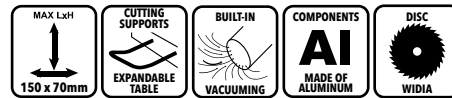

Power	1800	W
No load speed	4200	rpm
Disc diameter	ø250 x 30	mm
Weight	15.5	kg

Cutting capacity: Width x Height (W x H)

Straight	Mitre	Bevel	Compound	Upper Table
90°	45/90°	90/45°	-45/45°	
120 x 55mm	65 x 55 mm	120 x 35 mm	40 x 23 mm	0-33 mm



- Combined mitre saw with upper cutting table for ø210 mm widia discs.

- Single-phase 1200W motor.
- Robust aluminum design.
- Pre-adjusted rotary table for cuts at every 5°.
- Cutting guide

Included:

- TCT widia disc ø210 x 30 mm.
- Expandable cutting supports.
- Upper parallel guide.
- Lower disc cover.
- Vertical clamp
- Dust bag

DRILL / SCREWDRIVER 12V

BHL 111 BK

Code 1.3063



Battery voltage - Lithium	12	V
Battery capacity	2.0	Ah
No load speed	0-350/0-1350	rpm
Chuck Capacity	ø1.5 - ø10	mm
Chuck insertion	3/8" x 24	UNF
Tightening Torque	32	Nm
Settings	16 + 2	
Max. wood drilling	ø20	mm
Max. masonry drilling	ø10	mm
Max. steel drilling	ø10	mm
Weight	0.9	kg

- 2 Functions: Screwdriver & Drill**
- 2 Mechanical speeds for enhanced power & speed.
 - Power controlled by trigger.
 - Reversible rotation.

Included:

- x1 Charger
- x2 Batteries 2.0Ah
- HD-PE Carry Case

CHARGER & BATTERY

CHARGER 2.0 A
Code 12.900

BATTERY 2.0 Ah
Code 12.899



DRILL / SCREWDRIVER / HAMMER DRILL - 18V

BHL 118 CPK

Code 1.2988



Battery voltage - Lithium	18	V
Battery capacity	2	Ah
No load speed	0-750/0-1500	rpm
Impacts	0-6000 / 0-22000	
Chuck Capacity	ø0.8 - ø10	mm
Chuck insertion	3/8" x 24	UNF
Tightening Torque	32	Nm
Settings	17 + 1	
Max. wood drilling	ø32	mm
Max. masonry drilling	ø10	mm
Max. steel drilling	ø10	mm
Max. screws diameter	ø12	
Weight	1.5	kg

- 3 Functions: Drill, Screwdriver & Hammer drill

- Keyless Chuck with safety lock.
- Tightening torque with 17 + 1 settings.
- Belt clip
- L.E.D. guide light at working area.
- 2 Mechanical speeds.
- Reversible and electronic with microprocessor.

Included:

- x1 Charger
- x2 Batteries 2.0Ah
- HD-PE Carry Case

CHARGER & BATTERY

CHARGER 2.0 A - 18V
Code 12.902

BATTERY 2.0 Ah - 18V
Code 12.901



DRILL / SCREWDRIVER / HAMMER DRILL - 18V

B45 PK

No load speed	0 - 400 / 0 - 1400	rpm
Impacts	0 - 6000 / 0 - 21000	ipm
Chuck Capacity	ø1 - ø10	mm
Tightening Torque	40	Nm
Settings	22 + 1	
Max. wood drilling	ø30	mm
Max. masonry drilling	ø10	mm
Max. steel drilling	ø10	mm
Weight	1.2	kg



NEW
Check Availability



- **BRUSHLESS motor** (increased performance and service life.)

- **3 Functions: Drill, Screwdriver & Hammer drill.**

- Keyless Chuck with safety lock.
- Tightening torque with 22 + 1 settings.
- Belt clip.
- L.E.D. guide light.
- 2 Mechanical speeds.
- Reversible and electronic with microprocessor.

Included:

- x1 Charger
- x2 Batteries 2.0Ah
- HD-PE Carry Case



				Code
B45 P12K	1 x 2.0Ah	✓	✓	1.3895
B45 P14K	1 x 4.0Ah	✓	✓	1.3896
B45 P22 KIT 68	2 x 2.0Ah	✓	✓	1.3897

BATTERIES x2 INCLUDED	CHARGER INCLUDED	LIGHT L.E.D	ROTATION REVERSIBLE	SCREWDRIVER	DRILL NO IMPACTS	DRILL WITH IMPACTS	ELECTRONIC SPEED CONTROLLER	CARRY CASE PE-HD INCLUDED	SPEEDS 2 MECHANICAL
------------------------------------	----------------------------	-----------------------	-------------------------------	--------------------	----------------------------	------------------------------	---------------------------------------	--	----------------------------------

TH 710 BA

Code 1.2723

TH 710 BAK

Code 1.2690

Power	750	W
No load speed	0 - 3000	rpm
Impacts	0 - 48000	ipm
Chuck Capacity	ø2 - 13	mm
Insertion	1/2" x 20	UNF
Max. wood drilling	ø25	mm
Max. steel drilling	ø13	mm
Max. masonry drilling	ø13	mm
Weight	1.8	kg

- Drill with 2 functions: drill & impact drill
- Keyless chuck
- Speed regulator located on the trigger
- Reversible with button located over the trigger.

TH 710 BA Included:

- Auxiliary handle ajustable
- Depth regulator

TH 710 BAK Included:

- Auxiliary handle ajustable
- Depth regulator
- HD-PE Carry Case



HAMMER DRILL

TH 1000 AK

Code 1.558

Power	1000	W
No load speed	0 - 3000	rpm
Impacts	0 - 44800	ipm
Chuck Capacity	ø2 - 13	mm
Insertion	1/2" x 20	UNF
Max. wood drilling	ø25	mm
Max. steel drilling	ø13	mm
Max. masonry drilling	ø13	mm
Weight	2.3	kg

- Drill with 2 functions: drill & impact drill
- Drill with 2 functions: drill & impact drill
- Keyless chuck
- Speed regulator located on the trigger
- Reversible with button located over the trigger.

Included:

- Auxiliary handle ajustable
- Depth regulator
- HD-PE Carry Case.



ROTARY HAMMER SDS-PLUS

MH 26 K

Code 1.1805

Power	800	W
No load speed	0 - 1300	rpm
Impacts	0 - 5500	ipm
Impact energy	2.8	J
Insertion	SDS-PLUS	
Max. wood drilling	ø30	mm
Max. steel drilling	ø13	mm
Max. masonry drilling	ø26	mm
Max. core drilling	ø68	mm
Weight	2.8	kg

- Hammer with 4 Functions
- 1- Rotary for metal, wood & plastic
- 2- Rotary with percussion for construction materials
- 3- Chiseller for construction materials
- 4- Vario - lock to adjust the chisel position
- Electronic speed regulator
- Safety clutch

Included:

- Auxiliary lateral handle
- Depth regulator
- HD-PE Carry Case



MH 6 CK

SDS PLUS ROTARY HAMMER

Rotary hammer with SDS PLUS chuck for construction, renovation, and demolition work.

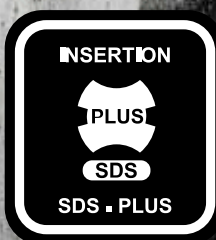

7 J IMPACT ENERGY
Effective demolition

VAT TECHNOLOGY
Vibration reduction

4 INTEGRATED FUNCTIONS
Maximum versatility

SAFETY CLUTCH
Motor protection

ROTARY HAMMER SDS-PLUS

MH 6 CK

Code 1.2313



Power	1700	W
No load speed	0 - 850	rpm
Impacts	4000	ipm
Impact energy	7	J
Insertion	SDS-PLUS	
Max. wood drilling	ø40	mm
Max. steel drilling	ø13	mm
Max. masonry drilling	ø26	mm
Max. core drilling	ø65	mm
Weight	5	kg

- **Hammer with 4 Functions**
- 1- Rotary** for metal, wood & plastic
- 2- Rotary with percussion** for construction materials
- 3- Chiseller** for construction materials
- 4- Vario - lock** to adjust the chisel position
- VAT: vibration absorbing system
- Safety clutch
- Included:**
- Auxiliary lateral handle
- Depth regulator
- HD-PE Carry Case



MINI ANGLE GRINDER \varnothing 115 mm

FH 700 C

Code 1.2730



Power	700	W
No load speed	11000	rpm
Disc diameter	\varnothing 115	mm
Spindle thread	M14	
Weight	1.6	kg

- Lightweight angle grinder with compact & balanced design.
- Powerful S1 constant service motor.
- Safety switch

Included:

- 2 Positions auxiliary handle



MINI ANGLE GRINDER \varnothing 115mm / \varnothing 125mm

FH 900 H

Code 1.3955

FH 901 H

Code 1.3694



Power	900	W
No load speed	11000	rpm
Disc diameter	\varnothing 115/125	mm
Spindle thread	M14	
Weight	1.8	kg

- Lightweight angle grinder with compact & balanced design.
- Powerful S1 constant service motor.
- Safety switch

Included:

- 2 Positions auxiliary handle

FH 901 G

Discs \varnothing 125 mm

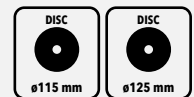

DELTA SANDER

LD 141 C

Code 1.3021



Power	135	W
No load speed	14000	rpm
Plate size	140 x 140 x 80	mm
Weight	0.8	kg

- Single handed delta sander
- Anti vibration system.
- Built-in vacuuming
- Self adhering plate

Included:

- Vacuum coupling
- x1 Sanding delta sheet



ORBITAL SANDERS

LH 187 C

Code 1.1126



Power	150	W
No load speed	12000	rpm
Plate size	90 x 187	mm
Orbit	2	mm
Weight	1.2	kg

- Clamps for no adherent sandpapers
- Built-in vacuuming
- Self adhering plate

Included:

- Vacuum coupling.
- x2 Sanding sheets.

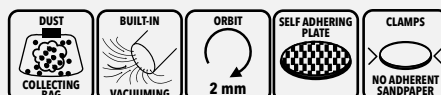

ROTORBITAL SANDER

LR 125 C

Code 1.2190



Power	300	W
No load speed	12000	rpm
Plate size	\varnothing 125	mm
Orbit	2	mm
Weight	1.5	kg

- 6 levels electronic speed regulator
- Self adhering plate
- Low vibration

Included:

- Dust collection tank.
- Sanding disc



CIRCULAR SAW

CH 185 C

Code 1.1544



Power	1300	W
No load speed	4500	rpm
Disc diameter	ø185 x 16	mm
Máx. cut 90°	65	mm
Máx. cut 45°	44	mm
Weight	4.8	kg

- Circular saw ø185 mm widia discs.

- Ready for coupling with an external vacuum cleaner.

- Cutting depth regulator.

- Bevel cuts 45°.

- Ergonomic handles

Included:

- Cutting guide.

- Widia disc ø190 x 30 mm



PLANER

PH 82 C

Code 1.2585



Power	710	W
No load speed	17000	rpm
Routing depth	0 - 2	mm
Depth levels	10	
Planing width	82	mm
Weight	2.4	kg

- Powerful planer with transmission belt motor

- Depth regulator by quarters of millimeter

- Powerful Built-in vacuuming system.

- Ready for coupling with an external vacuum cleaner.

- Quick blade change

Included:

- Lateral guide

- Dust collecting bag

- Blade set



RECIPROCATING SAW

SSH 210

Code 1.2766



Power	900	W
Saws per minute	0 - 3000	spm
Saw displacement	22	mm
Max. cut wood	180	mm
Max. cut steel	10	mm
Max. cut aluminum	25	mm
Max. cut PVC/profiles	100	mm
Weight	3.2	kg

- Quick blade change. T insertion

- Bevel cuts 0 a 45°

- Electronic speed regulator

- Ready for coupling with an external vacuum cleaner

Included:

- Lateral guide

- x1 Saw for wood

- x1 Saw for metal



JIG SAW

JS 55 CE

Code 1.2782



Power	500	W
No load speed	0 - 3000	rpm
Max. cut wood	55	mm
Max. cut steel	3	mm
Max. cut aluminum	6	mm
Weight	2	kg

- Quick blade change. T insertion

- Pendular cutting. 3 levels

- Bevel cuts 0 a 45°

- 6 levels electronic speed regulator

- Ready for coupling with an external vacuum cleaner

Included:

- Lateral guide

- x1 Saw for wood

- x1 Saw for metal



BENCH GRINDER

E 150 C

Code 2.534



Power	150	W
No load speed	2950	rpm
Grinding wheel	ø150 x 16 x 12.7	mm
Weight	5.7	kg

- **Powerful induction motor class E**
- Sealed ball bearings.
- Solid cast housing.
- Adjustable workpiece supports
- Transparent protectors against projections

Included:
 - x1 Grinding wheel ø150 mm A36
 - x1 Grinding wheel ø150 mm A60



BENCH GRINDER

EP 200 BM

Code 2.402



Power	350	W
No load speed	2950	rpm
Grinding wheel	ø200 x 20 x 16	mm
Weight	11.5	kg

- **Powerful flat curve motor over bearings**
- **Motor Dust protection sealing**
- Sealed ball bearings.
- Electromagnetic antidust switch.
- Adjustable workpiece supports
- Transparent protectors against projections

Included:
 - x1 Grinding wheel ø200 mm A36
 - x1 Grinding wheel ø200 mm A60



COMBINED BENCH GRINDERS

ECA 150 B

Code 2.404



Power	350	W
No load speed	2950	rpm
Grinding wheel	ø150 x 20 x 12.7	mm
Sharpening wheel	ø200 x 40 x 20	mm
Weight	8.5	kg

- **Bench grinder & Sharpener**
- **Powerful flat curve motor over bearings. Dust protection sealing**
- Electromagnetic antidust switch.
- Adjustable workpiece supports
- Transparent protectors against projections

Included:
 - x1 Grinding wheel ø150 mm
 - x1 Sharpening grinding wheel (wet/dry) ø200 mm

ECP 150 B

Code 2.403



Power	350	W
No load speed	2950	rpm
Grinding wheel	ø150 x 20 x 12.7	mm
Sharpening wheel	ø150	mm
Weight	7	kg

- **Bench grinder & Brush**
- **Powerful flat curve motor over bearings. Dust protection sealing**
- Electromagnetic antidust switch.
- Adjustable workpiece supports
- Transparent protectors against projections

Included:
 - x1 Grinding wheel ø150 mm
 - x1 Brush wheel ø150 mm

ECL 150 B

Code 2.405



Power	350	W
No load speed	2950	rpm
Grinding wheel	ø150 x 20 x 12.7	mm
Sharpening wheel	50 x 686	mm
Weight	10	kg

- **Bench grinder & Belt sander**
- **Powerful flat curve motor over bearings. Dust protection sealing**
- Electromagnetic antidust switch.
- Adjustable workpiece supports
- Transparent protectors against projections

Included:
 - x1 Grinding wheel ø150 mm
 - x1 Sanding sheet belt 50 x 686 mm.

HOT AIR GUN

SUH 2000 E

SUH 2000 EK

Code 1.380

Code 1.5786

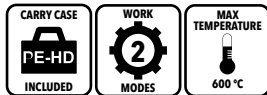

Power	2000	W
Airflow	250 - 450	l/min
Temperature	50 - 450 / 90 - 600	°C
Weight	0.9	kg

- Hot air gun with ceramic resistance
- Adjustable temperature & airflow.
- 2 workmodes
- Dries and peels varnish off. Folds plastic materials. Separates adhesive papers

SUH 2000 EK

Included:

- Nozzle set
- HD-PE Carry Case



PAINT GUN

EPG 300

Code 1.738

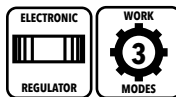

Power	400	W
Spray pressure	0.1 - 0.2	Bar
Tank capacity	0.8	L
Feeding capacity	300	g/min
Max. viscosity	30	DIN/sec
Nozzle	ø2.5	mm
Weight	0.9	kg

- Compact paint gun
- Safety nozzle lock.
- Paint flow regulator
- Nozzle with 3 work modes
- Quick tool disassembly
- Viscosity regulator

Included:

- Nozzle

Optional:

- Nozzle 1.80 mm for low viscosity paint.

Code 5015.192



PAINT GUN

EPG 800

Code 1.2828

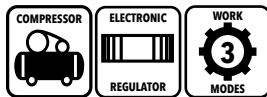

Power	800	W
Spray pressure	0.1 - 0.3	Bar
Tank capacity	900	ml
Feeding capacity	1100	ml/min
Max. viscosity	70	DIN/sec
Nozzle	ø2.5	mm
Weight	2.9	kg

- Compressor paint gun
- Paint flow regulator
- Nozzle with 3 work modes
- Viscosity regulator

Included:

- Nozzle
- Hose 1.8 m
- Carry band

Optional:

- 1.80 mm nozzle for low-viscosity paint.

Code: 5015.192



MULTI TOOL

MULTIDRILL 130

Code 1.651



Power	130	W
No load speed	8000 - 33000	rpm
Insertion	ø32	mm
Weight	0.5	kg

- Great precision multi tool**
- Electronic speed regulator
 - For all kind of materials
 - Suitable for a great range of accessories. Insertion ø32 mm
 - For drilling, sanding polishing, cutting & milling

- Included:**
- Extensible flexible shaft 110 mm.
 - 200 Accessories



MULTI TOOL

MULTIDRILL 180

Code 1.3637

NEW



Power	180	W
No load speed	8000 / 33000	rpm
Insertion	ø32	mm
Weight	0.5	kg

- Great precision multi tool**
- Electronic speed regulator
 - For all kind of materials
 - Suitable for a great range of accessories. Insertion ø32 mm
 - For drilling, sanding polishing, cutting & milling

- Included:**
- Extensible flexible shaft 110 mm.
 - 211 Accessories



MINI COMPRESSOR

MINICOM B A BATTERY

Code 1.3849



Voltage	7.4	V
Cylinder diameter	19	mm
Air Flow	19	l/min
Weight	1.67	kg

- Compact air compressor for cars**
- Connection to the car lighter.
 - Pressure gauge for maximum control.

- Included:**
- x3 Nozzles
 - Cable 30 cm.

ASH CLEANER

BC 1200 D

Code 1.1072



Power	1200	W
Suction capacity	19	Kpa
Tank capacity	20	L
Hose size	ø38 x 1000	mm
Weight	4.5	kg

- Specially designed for stoves, chimneys, barbeques. Suitable for dust, leaves, sawdust.**
- Metal tank with high thermic resistance.
 - Heat resistant flexible hose.
 - Aluminum nozzle resistant against abrasion and wear out.
 - HEPA Filter with metal protection.

- Included:**
- Hose
 - Aluminum nozzle
 - HEPA Filter

- Optional**
- HEPA Filter + Filter cover (washable)
Code 8190.98



**HIGH-PRESSURE WASHERS • GENERATORS •
PETROL GARDEN TOOLS • CHAIN SAWS • WATER PUMPS**

The latest technology in garden and outdoor machinery.

The **STAYER** Garden Tools line comprises a range of tools designed for garden work, aimed at both professional gardeners and homeowners looking to keep their gardens well-maintained using top-quality tools.

HIGH PRESSURE CLEANER

HL 145

Code 1.3954



NEW
Check Availability

Power	1800	W
Maximum flow rate	8.2	l/min
Turbo lance flow rate	6.2	
Max. Pressure	160	Bar
Work Pressure	120	Bar
Protection	IPX5	
Weight	8.2	kg

- High pressure cleaner with S1 constant service motor.
 - Total Stop System (TSS). Automatically switches off the pump when releasing the trigger to avoid tool damage.
 - Built-in soap tank.
 - High pressure hose 5m.
 - Built-in hose reel
- Included:**
- Gun with Safety switch lock.
 - Turbo lance
 - Foam tank
 - Cable 5 m.



HIGH PRESSURE CLEANER

HL 2200 B

Code 1.3872



NEW
Check Availability

Power	2200	W
Maximum flow rate	8.5	l/min
Turbo lance flow rate	6.6	
Max. Pressure	160	Bar
Work Pressure	125	Bar
Protection	IPX5	Bar
Weight	9.6	kg

- High pressure cleaner with S1 constant service motor.
 - Total Stop System (TSS). Automatically switches off the pump when releasing the trigger to avoid tool damage.
 - Built-in soap tank.
 - High pressure hose 6m.
 - Built-in hose reel
- Included:**
- Gun with Safety switch lock.
 - Turbo lance
 - Foam tank
 - Cable 5 m.



HIGH PRESSURE CLEANER

HL 2700 C INDUSTRIAL

Code 1.4107

Power	2500	W
Flow rate	8.5	l/min
Max. Pressure	180	Bar
Work Pressure	140	Bar
Protection	IPX5	
Weight	20.7	kg

- Portable high-pressure cleaner with powerful 2500W motor, maximum pressure of 180 bar.
- Total Stop System (TSS). The pump switches off automatically when the trigger is not pressed to prevent continuous damage to the motor and thus extend the service life of the pump.
- Gun with safety lock switch to prevent accidental use; quick connection to the hose.
- Reel for quick and easy hose storage.
- Heavy duty wheels and carrying handle for maximum ease of use.
- Includes leather tank.

- Included:**
- Gun with safety lock
 - Connection rod
 - 5 nozzles
 - Lather tank
 - Water filter

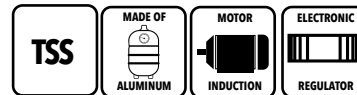

HIGH PRESSURE CLEANER

HL 3000 B IND

Code 1.3796

Power	3000	W
Maximum flow rate	9.2	l/min
Max. Pressure	200	Bar
Work Pressure	150	Bar
Protection	IPX5	
Weight	22.7	kg

- High pressure cleaner with induction motor.
- Brass pump
- Total Stop System (TSS). Automatically switches off the pump when releasing the trigger to avoid tool damage.
- Integrated soap tank.
- High pressure hose 5m.
- Built in hose reel.
- 5 m. cable.

- Included:**
- Gun with Safety switch lock.
 - Connector
 - Set 6 Nozzles
 - 0° / 15° / 25° / 40° / Soap / Turbo
 - Water filter
 - Brush

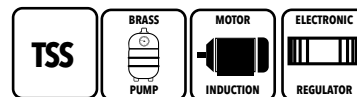

INDUSTRIAL HIGH PRESSURE CLEANER 110V

HL 2000 PSI

Code 1.2410

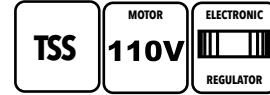

Power	1800	W	1800	W
Flow rate	6.5	l/min	1.72	GPM
Max. Pressure	160	Bar	2300	PSI
Work Pressure	138	Bar	2000	PSI
Protection	IPX5		IPX5	
Weight	18	kg	18	kg

- **110V Motor**
- **Total Stop System (TSS). Automatically switches off the pump when releasing the trigger to avoid tool damage.**
- Integrated soap tank.
- Soap flow regulator.
- High pressure hose 6m.
- Built in hose reel.
- Cable 5 m.

Included:

- Gun with Safety switch lock.
- Metal turbo lance
- Metal Vario power lance
- Water filter



INDUSTRIAL HIGH PRESSURE CLEANER

HL 11 B IND

Code 1.2783

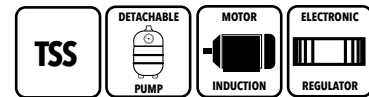

Power	2400	W
Maximum flow rate	10	l/min
Max. Pressure	200	Bar
Work Pressure	150	Bar
Protection	IPX5	
Weight	34	kg

- **High pressure cleaner with powerful copper wiring induction motor.**
- **Triple crankshaft brass pump**
- **Water pump with particle filter: extracts water from ponds, rivers and pools.**
- Water pressure regulator.
- Motor temperature regulator.
- Great capacity soap tank.
- High pressure hose 8m reinforced.
- Built-in hose reel.
- Built-in accessories housing.
- **Total Stop System (TSS)**

Included:

- Gun with Safety switch lock.
- Connector
- Set 6 Nozzles
0° / 15° / 25° / 40° / Soap
- Water filter

Detachable



PRUNING GAS CHAIN SAW

OLMO G1 - 250 C

Code 1.2740

Power	0.9 / 1.2	Kw/HP
Cylinder capacity	25.4	cm ³
No load speed	3000	rpm
Tank capacity	260	ml
Oil capacity	160	ml
Bar length	250	mm
Weight	3.5	kg

- Light gas chain saw for 250 mm bars.
- 2 stroke motor.
- Specially designed for pruning tasks.

- Automatic and adjustable chain lubrication.
- Safety brake against recoils, obstructions & rebounds.
- Gas / oil mixture ratio 40:1
- Quick & easy chain tightening.
- Suitable for bars up to 450 mm.

- Included:**
- Chain and bar OREGON.
 - Bar cover
 - Mixture bottle 600 ml.
 - Screwdriver & service key

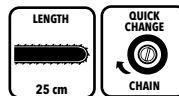

GAS CHAIN SAW

OLMO G3 - 450 C

Code 1.2741

Power	2.0 / 2.7	Kw/HP
Cylinder capacity	52	cm ³
No load speed	3000	rpm
Tank capacity	550	ml
Oil capacity	260	ml
Bar length	450	mm
Weight	6.5	kg

- Gas chain saw with 400 mm bar.
- 2 stroke motor.
- Automatic and adjustable chain lubrication.
- Visible oil level.
- Safety brake against recoils, obstructions & rebounds.
- Gas / oil mixture ratio 35:1

- Quick & easy chain tightening.
- Suitable for bars up to 450 mm.

- Included:**
- Chain and bar OREGON.
 - Bar cover
 - Mixture bottle 600 ml.
 - Screwdriver & service key

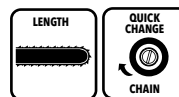

SEMI AUTOMATIC CHAIN SHARPENER

CS 85

Code 1.1356

Power	85	W
No load speed	6300	rpm
Disco	ø104 x 22.2 x 3.2	mm
Weight	2.5	kg

- Chain sharpener for all types of chain saws.
- Semi automatic system: the chain is secured with a clamp & can be moved automatically with a spring, but the clamp angle must be adjusted to use the sharpening disc.
- Chain clamp.
- Rotary clamp to adjust the sharpening angle.

- Included:**
- 3.2 mm sharpening disc



GAS HEDGE TRIMMER

GAS ROSE 710

Code 1.1354



Power	0.65	Kw
Cylinder capacity	22.5	cm ³
No load speed	3000 - 7500	rpm
Blade length	600	mm
Tank capacity	600	ml
Weight	6.2	kg

- Gas hedge trimmer.

- Safety brake against recoils, obstructions & rebounds.
- Easy start in every situation.
- Safety switch against unintentional triggerings.
- Ambidextrous handle.
- Ergonomic design with balanced mass.

Included:

- Double blade protector

GAS BLOWER/VACUUM/SHREDDER

GAS VENTO 25 B

Code 1.2800



Power	0.7	Kw
Cylinder capacity	26	cm ³
No load speed	3500 - 9000	rpm
Max. air speed	180	Km/h
Air flow rate	600	mm
Tank capacity	420	ml
Bag capacity	40	L
Weight	6	kg

- Gas blower / vacuum / shredder.

- Easy start.
- Telescopic tube for an easy transport and storage.
- Safety switch against unintentional triggerings.
- Ergonomic design with balanced mass.

Included:

- Dust bag
- Telescopic tube

GAS BRUSH CUTTER

GAS CUTTER 52

Code 1.3450



Power	1.25	Kw
Cylinder capacity	52	cm ³
No load speed	3000	rpm
Thread cutting diameter	ø440	mm
Disc size	ø255	mm
Support size	ø26 x 1500	mm
Tank capacity	1200	ml
Weight	8	kg

- Gas brush cutter with disc and nylon thread roll.

- Powerful 2 stroke motor.
- High resistance aluminum
- Easy start.
- Automatic thread advance.
- Gas / oil mixture ratio 40:1
- Adjustable handle & telescopic support.
- Ergonomic design with balanced mass.

Included:

- Double harness.
- Nylon thread roll ø2.4 x 2500 mm.
- 3 blade disc ø255 mm.
- Protection carter.

GAS BRUSH CUTTER / HEDGE TRIMMER / PRUNER

MULTIGAS CUTTER B

Code 1.2606



Power	0.75 / 1	Kw/HP
Cylinder capacity	33	cm ³
No load speed	3200	rpm
Thread cutting diameter	ø440	mm
Disc size	ø255	mm
Support size	1500 + 1000	mm
Tank capacity	0.8	L
Weight	12	kg

- Gas telescopic multi tool: Brush cutter with nylon thread & disc / Hedge trimmer / Pruner.

- Powerful 2 stroke motor.
- High resistance aluminum
- Easy start in every situation.
- Automatic thread advance.
- Adjustable handle & telescopic support.
- Ergonomic design with balanced mass.

Included:

- Double harness.
- Nylon thread roll ø2.4 x 2500 mm.
- 3 blade disc ø255 mm.
- Pruner head
- Hedge trimmer head
- Telescopic support 1m.
- Protection carter.

GENERATOR

GX 800

Code 1.2756

GENERATOR

Rated voltage	230	V
Rated current	3	A
Rated power	0.65	KW
Maximum power	0.8	KW
Output	1 x Single-phase	16A

MOTOR

Fuel	Unleaded 95 petrol	
Displacement	63	cc ³
Starting system	Manual	
Maximum power	2.0	HP
Tank capacity	4	L
Petrol / oil ratio	50 : 1	
Runtime	6	h
Sound power	66	dB(A)

Weight	15	kg
Dimensions	37.5 x 31.5 x 32	cm
Handle + Wheels	Handle only	
Packaging dimension	38x32x32.5	cm



- Safe connection to any kind of tool without damaging surges.
- Low consumption
- Voltage indicator.
- Output cable CC connection.

SILENT INVERTER GENERATOR

GID 2200 B

Code 1.2849

GENERATOR

Regulation	Inverter	
Rated voltage	230	V
Rated current	7.8	A
Rated power	1.8	KVA
Maximum power	2.0	KVA
Modo ECO	Si	
THD (Total Harmonic Distorsion)	< 3%	
DC output	1 x USB-C & 1 x USB-A 1 x 12V/8.3A	
Output	1 x Single-phase	16A

MOTOR

Type	4T OHV	
Fuel	Unleaded 95 petrol	
Displacement	79.7	cc ³
Starting system	Manual	
Starter battery	No	
Maximum power	3	HP
Tank capacity	4	L
Oil capacity	350	ml
Runtime	6	h
Sound power	62	dB (A)

Full quality electricity
INVERTER SYSTEM
 Completely safe and stabilized



Weight	18	kg
Dimensions	48x28.5x46	cm
Handle + Wheels	Handle only	
Packaging dimensions	52.5x32.5x55	cm

- Inverter output
- Safe connection to any kind of tool without damaging surges.
- Low consumption
- Low noise & vibration.
- Voltage indicator.
- Output cable CC connection.

Included:

- Output cable CC connection.
- Spark plug replacement.
- Screwdriver.
- Spark plug wrench.
- Tube for drenar aceite.

SILENT INVERTER GENERATOR

GID 3300

Code 1.4610

NEW
Check Availability

GENERATOR

Regulation	Inverter	
Rated voltage	230	V
Rated current	13	A
Rated power	3.0	KVA
Maximum power	3.3	KVA
Modo ECO	Si	
THD (Total Harmonic Distorsion)	< 3%	
DC output	1 x USB-C & 1 x USB-A	
Output	2 x Single-phase	16A

MOTOR

Type	4T OHV	
Fuel	Unleaded 95 petrol	
Displacement	143	cc ³
Starting system	Manual	
Starter battery	No	
Maximum power	5.7	HP
Tank capacity	4	L
Oil capacity	400	ml
Runtime	4	h
Sound power	66	dB (A)

Weight	20.5	kg
Dimensions	49.2x28.5x46	cm
Handle + Wheels	Handle only	
Packaging dimensions	52.5x32.5x55	cm



Generator with 100% stabilized inverter regulation, featuring two 230V single-phase sockets, and two USB ports (one Type-C and one Type-A).

of device without harmful power surges.
- Low consumption, noise, and vibration.
Output voltage indicator.
- Compact structure for generator protection and easy transport.

- Manual start.
- Safe connection to any type

SILENT INVERTER GENERATOR

GID 4000

Code 1.3341

GENERATOR

Regulation	Inverter	
Rated voltage	230	V
Rated current	15.2	A
Rated power	4.0	KVA
Maximum power	4.4	KVA
Modo ECO	Si	
THD (Total Harmonic Distorsion)	< 3%	
DC output	1 x USB-C & 1 x USB-A	
Output	2 x Single-phase	16A

MOTOR

Type	4T OHV	
Fuel	Unleaded 95 petrol	
Displacement	223	cc ³
Starting system	Manual+Electric	
Starter battery	Si	
Maximum power	6.8	HP
Tank capacity	12	L
Oil capacity	400	ml
Runtime	8	h
Sound power	66	dB (A)

Weight	40	kg
Dimensions	59.5x4.40x51.5	cm
Handle + Wheels	✓	
Packaging dimensions	64x48x59	cm



Suitable for connecting to solar installations.

- Inverter output.
- Safe connection to any type of device without harmful power surges.
- Low consumption.
- Low noise and vibration.
- Voltage indicator.
- **Conector para uso en instalaciones solares.**

GENERATORS AVR

GAV 3000

Code 1.4589

NEW



GAV 6000 E

Code 1.4588

NEW



GAV 8000 E

Code 1.4489

NEW



Safe Regulation
AVR
No Overvoltage

- AVR device that sets the output voltage.

- AVR sinusoidal output
- Safe connection to any kind of tool without damaging surges.
- Low consumption
- Voltage indicator.
- Output cable CC connection.
- Collapsible handle

Included:

- Output cable CC connection.
- Spark plug replacement.
- Screwdriver.
- Spark plug wrench.

GENERATOR

Regulation	AVR	
Rated voltage	230	V
Rated current	10.9	A
Rated power	2.5	KVA
Maximum power	2.8	KVA
ECO mode	No	
THD (Total Harmonic Distorsion)	< 15%	
DC output	12V/8.3A	
Output	2 x Single-phase	16A

MOTOR

Type	4T OHV	
Fuel	Unleaded 95 petrol	
Displacement	212	cc ³
Starting system	Manual	
Starter battery	No	
Maximum power	5.4	HP
Tank capacity	15	L
Oil capacity	600	ml
Runtime	13	h
Sound power	73	dB (A)

Weight	46	kg
Dimensions	59x4.40x46.2	cm
Handle + Wheels	Si	
Packaging dimensions	64x48x59	cm

GENERATOR

Regulation	AVR	
Rated voltage	230	V
Rated current	21.7	A
Rated power	5.0	KVA
Maximum power	5.5	KVA
ECO mode	No	
THD (Total Harmonic Distorsion)	< 15%	
DC output	12V/8.3A	
Output	1 x Single-phase 2 x Single-phase	32A 16A

MOTOR

Type	4T OHV	
Fuel	Unleaded 95 petrol	
Displacement	420	cc ³
Starting system	Manual+Electric	
Starter battery	Si	
Maximum power	10.9	HP
Tank capacity	25	L
Oil capacity	1100	ml
Runtime	9	h
Sound power	76	dB (A)

Weight	80	kg
Dimensions	68x52x54	cm
Handle + Wheels	Si	
Packaging dimensions	70x54x57	cm

GENERATOR

Regulation	AVR	
Rated voltage	230	V
Rated current	31.3	A
Rated power	7.2	KVA
Maximum power	7.7	KVA
ECO mode	No	
THD (Total Harmonic Distorsion)	< 15%	
DC output	12V/8.3A	
Output	1 x Single-phase 2 x Single-phase	32A 16A

MOTOR

Type	4T OHV	
Fuel	Unleaded 95 petrol	
Displacement	458	cc ³
Starting system	Manual+Electric	
Starter battery	Si	
Maximum power	13	HP
Tank capacity	25	L
Oil capacity	1100	ml
Runtime	7	h
Sound power	76	dB (A)

Weight	88	kg
Dimensions	68x52x54	cm
Handle + Wheels	Si	
Packaging dimensions	70x54x57	cm

INVERTER GENERATORS



HIGHER EFFICIENCY

Reduced weight and dimensions

40% less weight and 30% less volume.

Advantage: saves transportation and storage costs, more versatile and portable.

Lower gasoline consumption

consumption is reduced by up to 40%.

Advantage: savings in fuel consumption. In a 3kW generator, Inverter consumes 0.9 l/h at 50% load vs. standard 1.7 l/h at 50% load. In 500 hours of use, **400 liters of fuel are saved.**

LOWER CONSUMPTION

- Electronic output control for higher efficiency, precision and lower power consumption.

- Sine wave system to provide safe and high quality power.

- Safe connection to any type of device without harmful surges.

- Lower noise

- Lighter

- Higher efficiency

- Low power consumption

- Voltage indicator.

- Connector cable for DC output.

Included:

- Output cable CC connection.

- Spark plug replacement.

- Screwdriver.

- Spark plug wrench.



GID 2800 OF

Code 1.4590

NEW



GENERATOR

Regulation	Inverter	
Rated voltage	230	V
Rated current	12.2	A
Rated power	2.8	KVA
Maximum power	3.0	KVA
ECO mode	No	
THD (Total Harmonic Distorsion)	< 5%	
DC output	No	
Output	1 x Single-phase	16A

MOTOR

Type	4T OHV	
Fuel	Unleaded 95 petrol	
Displacement	208	cc ³
Starting system	Manual	
Starter battery	No	
Maximum power	5.7	HP
Tank capacity	5	L
Oil capacity	550	ml
Runtime	3.5	h
Sound power	72	dB (A)

Weight	23	kg
Dimensions	48.5x38.5x49.5	cm
Handle + Wheels	Handle only	
Packaging dimensions	50.5x40.5x52	cm

GID 3500 OF

Code 1.3342



GENERATOR

Regulation	Inverter	
Rated voltage	230	V
Rated current	13.9	A
Rated power	3.2	KVA
Maximum power	3.5	KVA
ECO mode	Si	
THD (Total Harmonic Distorsion)	< 5%	
DC output	12V/8.3A	
Output	2 x Single-phase	16A

MOTOR

Type	4T OHV	
Fuel	Unleaded 95 petrol	
Displacement	223	cc ³
Starting system	Manual	
Starter battery	No	
Maximum power	6.5	HP
Tank capacity	7.5	L
Oil capacity	600	ml
Runtime	6	h
Sound power	73	dB (A)

Weight	26.5	kg
Dimensions	43.3x37.6x46.2	cm
Handle + Wheels	Handle only	
Packaging dimensions	46.5x40x48.5	cm



GID 4000 OF

Code 1.3343

GID 8500 OF

Code 2.872



GENERATOR

Regulation	Inverter	
Rated voltage	230	V
Rated current	15.7	A
Rated power	3.6	KVA
Maximum power	4.0	KVA
ECO mode	Si	
THD (Total Harmonic Distorsion)	< 3%	
DC output	12V/8.3A	
Output	2 x Single-phase	16A

MOTOR

Type	4T OHV	
Fuel	Unleaded 95 petrol	
Displacement	223	cc ³
Starting system	Manual+Eléctric	
Starter battery	Si	
Maximum power	6.8	HP
Tank capacity	12.5	L
Oil capacity	600	ml
Runtime	8.5	h
Sound power	72	dB (A)

Weight	35.5	kg
Dimensions	53.3x41.6x42.3	cm
Handle + Wheels	Si	
Packaging dimensions	62x43.5x45	cm



GENERATOR

Regulation	Inverter	
Rated voltage	230	V
Rated current	34.8	A
Rated power	8.0	KVA
Maximum power	8.5	KVA
ECO mode	Si	
THD (Total Harmonic Distorsion)	< 3%	
DC output	1 x USB-C & 1 X USB-A	
Output	1 x Single-phase	16A
	1 x Single-phase	32A

MOTOR

Type	4T OHV	
Fuel	Unleaded 95 petrol	
Displacement	458	cc ³
Starting system	Manual+Eléctric	
Starter battery	Si	
Maximum power	13.6	HP
Tank capacity	25	L
Oil capacity	1100	ml
Runtime	10	h
Sound power	76	dB (A)

Weight	68.5	kg
Dimensions	69.3x64.6x61.3	cm
Handle + Wheels	Si	
Packaging dimensions	77.5x54x58	cm

CLEAN WATER PUMPS

CWP 400

Code 1.2860

Power	400	W
Max. pumping rate	7300	L/h
Max. head	7.5	m
Max. depth	7	m
Cable	10	m
Weight	4	kg

- **Submersible water pump with 400W motor for draining and pumping clean water up to 35°C.**

- Ideal for emptying swimming pools and pumping water from wells and springs. The pump is prepared both for punctual work and to be installed in a fixed point and to work in a stationary way.

- The pump is prepared to work either perched on the bottom of the water or suspended by the handle.

- Floating switch specially designed to activate and deactivate the pump automatically. As long as the switch floats above the pump, the pump will run continuously. When the water level drops, the switch lowers and deactivates the pump to prevent it from burning out.

- Capable of pumping water up to 7.5 m above the pump.

- Prepared to submerge and pump up to 7 m depth.

- Rotating pumping tube and equipped with different adapters for ø25 / 33 / 38 / 48 / 48 mm hoses to be able to adapt to different locations and all types of pipes and extraction hoses.

- 10m long cable to be able to connect the pump safely away from water.



DIRTY WATER PUMPS

DWP 750

Code 1.2861

Power	750	W
Max. pumping rate	12500	L/h
Max. head	8	m
Max. depth	7	m
Cable	10	m
Weight	4.6	kg

- **Submersible water pump with 750W motor for draining and pumping dirty water up to 35°C.**

- Specially designed for pumping water with sand, mud, debris and remains of leaves or plants.

- Ideal for emptying swimming pools and pumping water from wells and springs. The pump is prepared to work both for punctual work and to be installed in a fixed point and to work in a stationary way.

- The pump is prepared to work either perched on the bottom of the water or suspended by the handle.

- Floating switch specially designed to activate and deactivate the pump automatically. As long as the switch floats above the pump, the pump will run continuously. When the water level drops, the switch lowers and deactivates the pump to prevent it from burning out.

- Capable of pumping water 8 m above the pump.

- Prepared to submerge and pump up to 7 m depth.

- Rotating pumping tube and equipped with different adapters for ø25 / 33 / 38 / 48 / 48 mm hoses to be able to adapt to different locations and all types of pipes and extraction hoses.

- 10m long cable to be able to connect the pump safely away from water.



CLEAN AND DIRTY WATER PUMPS

DWP 1100 INOX

Code 1.2862

Power	1100	W
Max. pumping rate	15000	L/h
Max. head	9.5	m
Max. depth	7	m
Cable	10	m
Weight	5.9	kg

- **Submersible water pump with 1100W motor for draining and pumping clean and dirty water up to 35°C.**

- Specially designed for pumping water with sand, mud, debris and debris of leaves or plants, its structure reinforced with stainless steel makes it especially resistant to adverse environments.

- Ideal for emptying swimming pools and pumping water from wells and springs. The pump is prepared to work both for punctual work and to be installed in a fixed point and to work in a stationary way.

- The pump is prepared to work either perched on the bottom of the water or suspended by the handle.

- Floating switch specially designed to activate and deactivate the pump automatically. As long as the switch floats above the pump, the pump will run continuously. When the water level drops, the switch lowers and deactivates the pump to prevent it from burning out.

- Capable of pumping water 9.5 m above the pump. Prepared to submerge and pump up to 7 m depth.

- Rotating pumping tube and equipped with different adapters for ø25 / 33 / 38 / 48 / 48 mm hoses to be able to adapt to different locations and all types of extraction tubes and hoses.

- 10m long cable to be able to connect the pump safely away from water.





ACCESSORIES

At **STAYER**, we specialize in a wide selection of accessories for construction, wood, and metal. Here you will find all the accessories that will help you get the most out of your professional tools.



ACCESSORIES

ADAPTERS



3-piece HEX to 1/4" adapter set. For using socket wrenches with screwdrivers and drills.

3 pcs

From	To	Code 	Code 
HEX	1/4" - 3/8" - 1/2"	12.670	11.61



3-piece SDS PLUS adapter set. For using socket wrenches with rotary hammers.

3 pcs

From	To	Code 	Code 
SDS PLUS	1/4" - 3/8" - 1/2"	12.1325	11.62



SDS PLUS to M14 Adapter. Length 110mm.

1 pcs

From	To	Code 	Code 
SDS PLUS	M14	12.1313	12.198



HEX to 1/4" Adapter. For using socket wrenches with screwdrivers and drills.

1 pcs

From	To	Code 	Code 
HEX	1/4"	12.1322	11.58

HEX to 1/2" Adapter. For using socket wrenches with screwdrivers and drills.

1 pcs

From	To	Code 	Code 
HEX	1/2"	12.1316	11.52

SCREWDRIVER BITS

PHILLIPS BIT



Model	Length	Pcs	Code
Phillips Bit PH1	L25 mm	PACK x5	12.1328
Phillips Bit PH2	L25 mm	PACK x5	12.1329
Phillips Bit PH2	L50 mm	PACK x3	12.1330
Phillips Bit PH3	L25 mm	PACK x5	12.1331

POZIDRIVE BIT



Model	Length	Pcs	Code
Pozidrive Bit PZ1	L25 mm	PACK x5	12.1332
Pozidrive Bit PZ2	L25 mm	PACK x5	12.1333
Pozidrive Bit PZ2	L50 mm	PACK x3	12.1334
Pozidrive Bit PZ3	L50 mm	PACK x5	12.1335

TAMPER-PROOF TORX BIT



Model	Length	Pcs	Code
Tamper-Proof Bit PTS10	L25 mm	PACK x2	12.1336
Tamper-Proof Bit PTS15	L25 mm	PACK x2	12.1337
Tamper-Proof Bit PTS20	L25 mm	PACK x2	12.1338
Tamper-Proof Bit PTS25	L25 mm	PACK x2	12.1339
Tamper-Proof Bit PTS27	L25 mm	PACK x2	12.1340
Tamper-Proof Bit PTS30	L25 mm	PACK x2	12.1341
Tamper-Proof Bit PTS40	L25 mm	PACK x2	12.1342

ALLEN BIT



Model	Length	Pcs	Code
Allen Bit PHX3	L25 mm	PACK x5	12.1343
Allen Bit PHX4	L25 mm	PACK x5	12.1344
Allen Bit PHX5	L25 mm	PACK x5	12.1345

SLOTTED BIT



Model	Length	Pcs	Code
Slotted Bit 4.5	L25 mm	PACK x5	12.1346
Slotted Bit 4.5	L50 mm	PACK x3	12.1347

BIT HOLDERS



Model	Length	Code	Code
		STAYER	ST GRINDING
Magnetic Bit Holder (With retention)	65 mm	12.1319	11.55
Magnetic Bit Holde	150 mm	12.1317	11.53
Magnetic Bit Holde	300 mm	12.1318	11.54
SDS PLUS Bit Holder	75 mm	12.1320	11.56



EXTENDABLE MAGNETIC BIT HOLDER



Model	Length	Ext. Length	Code	Code
			STAYER	ST GRINDING
Extendable Magnetic Bit Holder	80 mm	60 mm	12.912	11.64

DRILL ACCESSORIES

40 PCS SET (BITS & SOCKET SPANNER)



Pcs	Length	Model	Code
7	50	1xPH1 / 2xPH2 / 1xPH3 / 1xPZ1 / 2xPZ2	12.667
28	25	1xPH1 / 2xPH2 / 1xPH3 1xPZ1 / 2xPZ2 / 1xPZ3 1xT10 / 1xT15 / 2xT20 / 2xT25 / 1xT30 / 1xT35 / 1xT40 1xH3 / 1xH4 / 1xH5 / 1xH6 1xSL3 / 1xSL4 / 1xSL5 / 1xSL6 1xS1 / 1xS2	
3	65	(Socket spanner) 6 / 8 / 10	
1	70	1xPH2	
1 Adaptor			



25 mm **50 mm** **70 mm**

x4 x4 x4 x2 x4 x10 x3 x4 x3 x1

HARDENED IMPACT SCREWING BITS - 24 PCS SET



Pcs	Length	Model	Code
5	90	3xPH2 / 2xPZ2	12.668
7	50	1xPH1 / 3xPH2 2xPZ2 / 1xPZ3	
7	25	1xPH1 / 2xPH2 / 1xPH3 1xPZ1 / 1xPZ2 / 1xPZ3	
3	48	(Socket spanner) 6 / 8 / 10	
1	60	Adaptor	
1		Quick change adaptor	

ADVANTAGES

- Hardened carbon steel bits for an improved friction and impact resistance.
- Specially designed for **Impact screwdrivers**.
- Magnetic quick adaptor included.



25 mm **50 mm**

x3 x4 x3 x4 x3

90 mm

x3 x2

x1 Quick change adaptor
x1 Adaptor

DRILL ACCESSORIES

BITS SET (QUICK CHANGE ADAPTOR) - 32 PCS



Pcs	mm	Model	Code
30	25	1xPH1 / 2xPH2 / 1PH3 1xPZ1 / 2xPZ2 / 1xPZ3 1x SL3 / 1xSL4 / 1xSL5 / 1xSL6 Hex 1x 3 / 1x 4 / 1x5 / 1x6 2xT10 / 2xT15 / 2xT20 / 2xT25 / 2xT27 / 2xT30 / 2xT40	1.1064
1	25	Adaptor	
1		Quick change adaptor	

BITS & SOCKET SPANNER, QUICK CHANGE ADAPTOR - 28 PCS SET



Pcs	Length	Model	Code
20	25	1xPH1 / 2xPH2 / 1xPH3 1xPZ1 / 2xPZ2 / 1xPZ3 1xH3 / 1xH4 / 1xH5 1xSL3 / 1xSL4 / 1xSL5 / 1xSL6 1xT10 / 1xT15 / 2xT20 / 2xT25 / 1xT27	12.669
6		(Socket wrenches) 5 / 6 / 8 / 10 / 12 / 13	
1		Adaptor	
1		Quick change adaptor	



25 mm



x1 Quick change adaptor

SET IMPACT SOCKET WRENCH

Set of 4 socket wrenches 1/2".
Diameters 17/ 19/21/22 x81.5mm

Code 12.871



70-PIECE STRAIGHT SHANK DRILL BIT AND BIT SET



70-piece Set	Specifications	Code
10 Concrete drill bits	Ø 3,4,7,10 (x1) Ø 5,6,8 (x2)	1.1041
6 Titanium steel drill bits	Ø 2,3,4,5,6,8	
6 Wood drill bits	Ø 3,4,5,6,8,10	
30 Screwdriver bits	25	
10 Screwdriver bits	50	
Magnetic bit holder	60	
Countersink bit	Ø 12.5	
2 Screw finders		
3 Nut setters	Ø 6,7,8	
Gauge		
Socket		

101-PIECE STRAIGHT SHANK DRILL BIT AND BIT SET



101-piece Set	Specifications	Code
19 HSS Metal drill bits	Ø 1 - 8 mm	1.4530
6 Masonry drill bits	Ø 3 - 10 mm	
6 Wood drill bits	Ø 3 - 10 mm	
3 Flat wood drill bits (Spade bits)	Ø 12, 16, 20 mm	
50 Bits (25mm)	PH, PZ, SL, T, H	
10 Bits (50mm)	PH, PZ, SL, T	
4 Sockets	6, 8, 10, 12 mm	
Additional Accessories	Magnetic bit holder, countersink, diameter gauge, and depth stop.	

FLEXIBLE SHAFT



Code 12.590



NYLON CUP BRUSH



Brushes made of nylon filaments with aluminum oxide abrasive grains. It does not scratch or alter the dimensions of the pieces. Ø75mm Coarse grain.

USE
Cleaning and polishing.

Code: 12.868

NYLON CIRCULAR FLAT BRUSH



Filaments with great flexibility to avoid breakage and to penetrate all angles; it allows the brushing of irregular pieces extending the life of the brush. Ø75mm Coarse grain.

USE
For cleaning and polishing.

Code: 12.869

BRASS BRUSHES

3 pcs brush set

Code: 1.2368



Ø 63 x 6

Ø 12

Ø 63

CAR SET

Triple kit for car restoration to be used with a drill.

Its use requires electric or battery-powered drill.

Carefully read the instructions for use, step by step through the entire process using the appropriate sandpaper for each finish/job. **Recommended for use with 12-14-18V battery-powered screwdriver.**



Lamp restoration

- Easy and fast scratch removal with great transparency recovery with sanding sheets P 800, 1200, 1500 & 2000.
- Finished with a special paste applied with sponge and rubber plate.
- Increases lamp sharpness for an increased driving security, significantly reducing fatigue.



Wheel tire restoration

- Conceals scratches using a polishing paste applied by sponge and rubber plate.
- Suitable for all types of wheel tires.



Bodywork restoration

- Conceals bodywork scratches no matter the car's color.
- Thanks to the restoration paste applied by sponge the bodywork recovers a brand new look.



100 ml tube

100 ml tube
Tire paste

100 ml tube
metal sheets paste

Code: 1.1923

Included



Self adhering plate
shaft Ø6 mm - Diameter Ø75mm



Wool pad
for rubber plate



Sponge
for rubber plate



Sponge



x3 self adhering sanding
discs for bodywork
P240 / P360 P600



x4 self adhering sanding discs
for lamps P800 / P1200 / P1500 / P2000



Microfiber cloth

MASONRY & CONCRETE BITS

XIMPACT

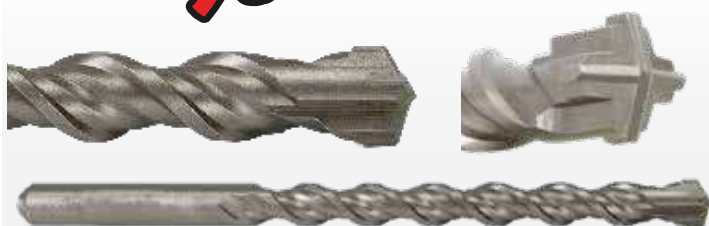

Ø(mm)	L(mm)	Minimum order	Code 	Code 
4	85	5	12.1283	891.489
5	90	5	12.1284	891.490
6	100	5	12.1285	891.491
8	120	5	12.1287	891.493
10	120	5	12.1288	891.494
12	150	5	12.1289	891.495

MULTI-MATERIAL DRILL BITS

APPLICATIONS

Masonry/concrete, bricks, Natural stone drilling.

USE

Cylindrical shank for drill use.



Ø(mm)	L(mm)	Minimum order	Code
3	70	5	12.1025
4	75	5	12.1026
5	85	5	12.1027
6	100	5	12.1028
6	150	5	12.1029
8	120	5	12.1030
8	150	5	12.1031
10	120	5	12.1032
10	150	5	12.1033
12	150	5	12.1034
14	150	5	12.1035

5 DRILL BITS SET

Ø(mm): 5-6-8-10-12v

Code: 11.5769



5 DRILL BITS SET

Ø(mm): 4-5-6-8-10

Code: 12.734



MULTI-MATERIAL DRILL BITS



Ø(mm)	L(mm)	Minimum order	Code
3	70	5	12.1036
4	75	5	12.1037
5	85	5	12.1038
6	100	5	12.1039
6	150	5	12.1040
8	120	5	12.1041
8	150	5	12.1042
10	120	5	12.1043
10	150	5	12.1044
12	150	5	12.1045



STAYER

ACCESSORIES



MASONRY HOLE SAWS



- Hole saw for partition walls with vacuum-brazed tungsten carbide edge.
- Pilot drill bit with TCT tip that facilitates hole starting and wobble-free centering. Threaded into the hole saw and removable without tools.
- Vacuum-brazed tungsten carbide edge: high-strength bonding directly to the metal body for maximum durability and precision in masonry.
- Efficient dust evacuation.
- Compatible with standard chuck drills, ideal for professional use.
- Available diameters: 33 - 103 mm.

MASONRY HOLE SAWS

Ø(mm)	Code 	Code <i>ST GRANING</i>
33	12.1046	12.176
43	12.1047	12.177
53	12.1048	12.178
68	12.1049	12.179
73	12.1050	12.180
83	12.1051	12.181
103	12.1052	12.182

ARBOR WITH PILOT DRILL BIT

Ø(mm)	Length mm	Code 	Code <i>ST GRANING</i>
9	139	12.1290	12.183
9	320	12.1291	12.184

MASONRY BITS

VACUUM BRAZED DIAMOND BITS FOR PORCELANIC



ADVANTAGES

- **VACUUM BRAZING** technology that improves the diamond grains retention, achieving a significant larger **life span while increasing its heat resistance and abrasion wear**
- Inner vegetal wax coating as lubricant to cool down the bit, reducing temperature, increasing its lifespan.
- Dry cut diamond bits, **no water cooling needed.**
- Perfect **gres and porcelanic** finish.

Ø.	Insertion	Code
Set de 3		
6-8-10	HEX	5.1182

Ø.	Insertion	Code	Code
5	HEX	5.1205	40.70
6	HEX	5.1171	40.56
8	HEX	5.1172	40.57
10	HEX	5.1173	40.58
12	HEX	5.1263	40.78
14	HEX	5.1264	40.79
20	HEX	5.1265	40.117
28	HEX	5.1452	40.118
35	HEX	5.1453	40.119
45	HEX	5.1454	40.120

APPLICATIONS

For drilling ceramic materials, stoneware, porcelain tiles, marble, and granite.

USE

- 1/4" Hex shank for drill use (rotary only, no hammer action).

- Before drilling, the target area can be marked with masking tape to prevent the bit from slipping. However, this is not strictly necessary: with diamond drill bits, you should start drilling with the bit tilted at an angle between 15-35° and apply orbital movements. This prevents the bit from slipping and extends its service life.

- Adjust the RPM to the diameter of the drill bit being used; this will maximize the service life of the bits.

- If highly precise holes in walls are required, we offer a suction cup drilling guide accommodating various sizes, ranging from 4 mm to 12 mm.

- We also offer a drill adapter, which allows M14 drill bits/hole saws—originally designed for angle grinders—to be used with standard drills.

SUCTION CUP DRILLING GUIDE

SUCTION CUP

FEATURES

Suction cup to attach the guide to multiple wall types. Ceramic, Gres, Gres Porcelanic, Glass, marble, metal. Metal reinforced holes.

4-5-6-7-8-10-12mm diameters.

Code: 5.1191



ADAPTOR

FEATURES

Angla grinder M14 vacuum brazed diamond cores adaptor to HEX for drill usage.



STAYER

Code: 5.1279

ST GRINDING

Code: 40.62

SDS PLUS TO M14 ADAPTER (110 mm)



STAYER

Code: 12.1313

ST GRINDING

Code: 12.198

GLASS & TILES LANCE BITS SET (5 PCS)



ADVANTAGES

- Reinforced widia point that enables a higher precision and drilling speed.
- "U" shaped groove for an improved debris extraction, avoiding clogging.
- Cylindrical shank with 2 flat faces to improve the chuck retention.

APPLICATIONS

Glass and ceramic tiles drilling.

USE

Cylindrical shank with 2 flat faces to improve the chuck retention, no impact drilling.

Ø (mm)	Point	Code
Set of 5		
3 x 6mm 1 x 8mm 1 x 10mm	TCT Widia	12.711



METAL BITS

RECOMMENDATIONS AND SAFETY GUIDELINES

- Use coolants when drilling metals to reduce excessive bit heating and extend its lifespan.
- Adapt your tool's speed according to the material to be drilled. The harder the material, less speed must be used.
- Use protection glasses to protect your eyes from metal debris. Use gloves, ear protection and a breathing mask.

- To perform big diameter holes it's advisable to start using a smaller bit first to improve the bigger bits performance avoiding accidental slides. The smaller bit diameter must be at least the same size than the minimum distance between the cutting edges from the bigger bit.
- When drilling on thin metal sheets, hold both sides with wood pieces to improve the grip while preventing the piece moving thus increasing the drilling quality.

10 BITS SET, HSS-R, DIN 338, ROLL LAMINATED, 118° TIP



ADVANTAGES

- **Helicoidal HSS bit** Made from high quality super fast steel DIN 338, **roll laminated**, right cutting, Type N, Cylindrical shank.
- **Sharpened bit tip with a 118° attack angle**, to improve the drilling quality on soft materials.
- Tensile strength < **900 N/mm²**.
- Double spiral groove for an optimal **debris extraction**.
- High elasticity to reduce small diameter bits breaking.
- **Black oxide coating** to improve the cutting quality while increasing the bit's heat resistance.

APPLICATIONS

Specially suited to drill cast iron and steels with a hardness level up to 900 N/mm2, non ferrous metals like aluminum, copper, brass, hard plastics and soft alloys.

USE

Use with a hand drill, bench drills with a 10 mm or more chuck.

Ø (mm)	TI (mm)	UI (mm)	Code
1	34	12	12.635
2	49	24	
3	61	33	
4	75	43	
5	86	52	
6	93	57	
7	109	69	
8	117	75	
9	125	81	
10	133	87	

10 BITS SET, HSS-G, DIN 338, RECTIFIED, 135° TIP



ADVANTAGES

- **Helicoidal HSS bit** Made from high quality super fast steel DIN 338, **rectified**, right cutting, Type N, Cylindrical shank.
- **Sharpened bit tip with a 135° attack angle**, improved drilling on hard materials increasing the drilling speed over beveled edge bits. Sharpened in accordance to DIN 1412 C.
- **Split Point** to avoid bit sliding while improving drilling quality.
- **Milled bit** for an optimal precision.
- Tensile strength < **1000 N/mm²**.
- Double spiral groove for an optimal **debris extraction**.
- **Black oxide coating** to improve the cutting quality while increasing the bit's heat resistance.

APPLICATIONS

Specially suited to drill cast iron and steels with a hardness level up to 1000 N/mm2, non ferrous metals like aluminum, copper, brass, hard plastics and medium alloys.

USE

Use with a hand drill, bench drills with a 10 mm or more chuck.

Ø (mm)	TI (mm)	UI (mm)	Code
1	34	12	12.636
2	49	24	
3	61	33	
4	75	43	
5	86	52	
6	93	57	
7	109	69	
8	117	75	
9	125	81	
10	133	87	



Split point 135° attack angle Precise and fast drilling.

Avoids bit sliding over the material to be drilled

METAL BITS

19 BITS SE, HSS-CO, DIN 338, RECTIFIED WITH COBALT, 135° TIP



ADVANTAGES

- **Helicoidal HSS-Co** made from high quality super fast steel alloyed with **5% Cobalt**, DIN 338, rectified, right cutting, Type N, Cylindrical shank.
- **Sharpened bit tip with a 135° attack angle**, improved drilling on hard materials increasing the drilling speed over beveled edge bits. Sharpened in accordance to DIN 1412 C.
- Split Point to avoid bit sliding while improving drilling quality.
- Milled bit for an optimal precision.
- Tensile strength < **1200 N/mm²**.
- Double spiral groove for an optimal **debris extraction**.
- **Long lifespan**: Cobalt alloy significantly improves **heat and wear resistances**.

Ø (mm)	TI (mm)	UI (mm)	Code
1	34	12	
1,5	40	18	
2	49	24	
2,5	57	30	
3	61	33	
3,5	70	39	
4	75	43	
4,5	80	47	
5	86	52	
5,5	93	57	12.637
6	93	57	
6,5	101	63	
7	109	69	
7,5	69	69	
8	117	75	
8,5	117	75	
9	125	81	
9,5	125	81	
10	133	87	



APPLICATIONS

Specially suited for **stainless steel drilling, alloy and non alloy steels** with a tensile strength up to 1200 N/mm², grey casting and steel casting.

USE

Use with a bench drill, **not suitable for hand drills due to the bits hardness**.

RECTIFIED COBALT BITS



COBALT



Split point 135° attack angle Precise and fast drilling.
Avoids bit sliding over the material to be drilled



Uds.	Minimum order	Ø (mm)	TI (mm)	UI (mm)	Code
1	5	1	34	12	12.638
1	5	1,5	40	18	12.639
1	5	2	49	24	12.640
1	5	2,5	57	30	12.641
1	5	3	61	33	12.642
1	5	3,5	70	39	12.643
1	5	4	75	43	12.644
1	5	4,5	80	47	12.645
1	5	5	86	52	12.646
1	5	5,5	93	57	12.647
1	5	6	93	57	12.648
1	5	6,5	101	63	12.649
1	5	7	109	69	12.650
1	5	7,5	109	69	12.651
1	5	8	117	75	12.652
1	5	8,5	117	75	12.653
1	5	9	125	81	12.654
1	5	9,5	125	81	12.655
1	5	10	133	87	12.656
1	5	11	141	93	12.657
1	5	12	149	99	12.658
1	5	13	157	105	12.659

RECTIFIED COBALT BITS - HSS M35

Recommended for column drills
HSS M35 bits, 8% cobalt alloy, rectified, Split point with a 135° attack angle, 13mm reduced shank with 3 flat faces for an improved grip.

Pcs.	Ø (mm)	TI (mm)	UI (mm)	Code
1	14	160	108	12.847
1	15	169	114	12.848
1	16	178	120	12.849

STRAIGHT STEP BITS, HSS TITANIUM COATED

3 STRAIGHT BITS SET, HSS TITANIUM COATED.



ADVANTAGES

- **Step HSS bit** made of high speed steel, **coated with titanium nitride.**
- **3 faced shank** to avoid chuck sliding.
- **The titanium nitride** significantly increases the bit lifespan allowing harder steel drilling.
- **Sharpened tip** to improve drilling quality on softer materials, without previous marking needed.
- **Double grooving** for a faster and softer drilling with an **improved debris removal.**
- We advise doing a previous smaller drilling before using this bit on harder materials.

APPLICATIONS

Suited for thin metal sheet drilling, non ferrous materials, steels, copper, brass, aluminum, PVC, glassfibre & wood.
3 faced Cylindrical shaft.

USE

Use with a hand drill, bench drills with a 10 mm or more chuck.



Case included				
Ø (mm)	N° steps	Shank	Tl (mm)	Code
4-6-8-10-12 14-16-18-20	9	3-sided	75	12.671
12-13-14-15-16 17-18-19-20	9	3-sided	75	
6-8-10-12-14-16-18-20- 22-24-26-28-30	13	3-sided	95	

SPIRAL STEP HSS-M2 TITANIUM COATED BITS



ADVANTAGES

- **HSS-M2 step drill bit** made of high speed steel, **coated with titanium nitride.**
- **3 faced shank** to avoid chuck sliding.
- **The titanium nitride** significantly increases the bit lifespan allowing harder steel drilling.
- **Sharp tip that improves drilling in softer metals,** and without the need to mark the workpiece beforehand.
- **Split point, prevents slippage** and accelerates the drilling of the drill bit.
- **Sharpened tip to improve drilling quality** on softer materials, without previous marking needed.
- **Spiral grooving for an improved** debris removal reducing vibrations and increasing drilling speed.
- We advise doing a previous smaller drilling before using this bit on harder materials.



APPLICATIONS

Suited for thin metal sheet drilling, non ferrous materials, steels, copper, brass, aluminum, PVC, glassfibre & wood.
3 faced Cylindrical shaft.

USE

Use with a hand drill, bench drills with a 10 mm or more chuck.

Case included				
Pcs	Ø (mm)	N° steps	Tl (mm)	Code
1	4-6-8-10-12 14-16-18-20	9	75	12.672
1	6-8-10-12-14-16-18-20- 22-24-26-28-30	13	95	12.673

METAL COUNTERSINK BITS

6 COUNTERSINK BITS SET FOR METAL

ADVANTAGES

- Conic countersink bits DIN 335, shape C. 90° milling angle. Rectified hard metal HSS.
 - 3 flat faced Cylindrical shank to avoid chuck sliding.
 - Split point to improve precision, according to DIN 1412 C.
 - 118° cutting angle, right cutting. Optimal material removal, reducing noise, vibrations, increasing the bit lifespan.
 - Included bits: (6,3 - 8,3 - 10,4 - 12,4 - 16,5 - 20,5 mm)
- Suitable for non ferrous metals, steel, termoplastics and hard plastics as well as metal sheets up to 5mm thickness.

APPLICATIONS

Specially designed for metal sheets drilling, up to 5mm as well as non ferrous metals, steel and alloyed steel up to 1.000 N/mm², copper, brass, aluminum, PVC, Fiberglass & wood.

USE

Use with a hand drill, bench drills with a 10 mm or more chuck.



Ø (mm)	Description	Shank (mm)	Code
6,3	HSS 90°	3	12.674
8,3	HSS 90°	4	
10,4	HSS 90°	5	
12,4	HSS 90°	6	
16,5	HSS 90°	8	
20,5	HSS 90°	10	



8% COBALT BIMETALLIC CORES

CORES WITH CENTERING BIT FOR PLUMBERING AND ELECTRICISM



ADVANTAGES

- Bimetallic saw cores with a 8% cobalt. This alloy increases the teeth resistance on harder materials, increasing the core lifespan. Allowing for long drilling sessions without teeth wearing out.
- Variable teeth alignment between 4 & 6 TPI (Teeth per inch), to ease the drilling.
- **Arbor and centering bit sold separately.**
- For great diameter hole boring. From 20 up to 76 mm. 38 mm cutting depth.

APPLICATIONS

Suitable for stainless steel drilling, steel and alloyed steel, cast metals, wood, plywood, plastics, drywall.

USE

Use with a hand drill, bench drills once the core is attached to an arbor.

Pcs.	Ø (mm)	Code
1	20	12.720
1	22	12.721
1	25	12.722
1	32	12.723
1	35	12.724
1	40	12.725
1	51	12.726
1	60	12.727
1	64	12.728
1	76	12.729
1	102	12.851
1	121	12.852
1	152	12.853



Arbors with spring and centering bit, HSS M2 high quality for bimetallic Cores.

Hex 3/8" insertion suitable for all chucks.

Cores Ø (mm)		Code
14 - 30	Arbor & bit	12.730
32 - 210	Arbor & bit	12.731
14 - 30	SDS-PLUS	12.854
32 - 210	SDS-PLUS	12.855



Spare centering bit HSS M2.

Ø (mm)	Code
6.35 x 75	12.733

WOOD DRILL BITS

SPIRAL BITS



ADVANTAGES

- 3 points HSS spiral bits.
- Centering point with scaled cutter, for an improved cutting precision and drilling speed.
- Double spiral for an improved shavings removal.

APPLICATIONS

Suitable for all types of wood drilling.

USE

Use a hand drill. Cylindrical shank.



Set	Ø (mm)	TI (mm)	Insertion mm	Code
5	4-5-6-8-10	75-152	47-102	12.760

*Included one box.

Pcs.	Minimum order	Ø (mm)	TI (mm)	Insertion mm	Code
1	5	3	60	32	12.749
1	5	4	75	47	12.750
1	5	5	85	52	12.751
1	5	6	93	58	12.752
1	5	7	109	71	12.753
1	5	8	117	77	12.754
1	5	9	125	83	12.755
1	5	10	133	90	12.756
1	5	11	140	92	12.757
1	5	12	152	102	12.758
1	5	13	152	102	12.759

SPADE BITS



ADVANTAGES

- Flat spade bits made of reinforced carbon steel, for large diameter wood drilling.
- Centering point with double balde for an improved precision and cutting speed.

APPLICATIONS

Suitable for all types of wood drilling.

USE

Use a hand drill or bench drill. Hex shank



Set	Ø (mm)	TI (mm)	Insertion mm	Code
6	16-18-20-22-25-32	152	6.35	12.748

- Grooved edge to improve material removal while increasing the cutting speed.
- Diameters from 14 mm up to 32 mm.

Pcs.	Ø (mm)	TI (mm)	Insertion (mm) HEX	Code
1	14	152	6.35	12.737
1	16	152	6.35	12.738
1	18	152	6.35	12.739
1	20	152	6.35	12.740
1	22	152	6.35	12.741
1	24	152	6.35	12.742
1	25	152	6.35	12.743
1	26	152	6.35	12.744
1	28	152	6.35	12.745
1	30	152	6.35	12.746
1	32	152	6.35	12.747

SALOMONIC BITS (LEWIS)



ADVANTAGES

- Hardened carbon steel bits, with centering tip and spiral groove.
- Specially designed for fast and precise deep through holes drilling.
- The bit spiral groove allows for an optimal sawdust extraction, greatly increasing the drilling speed.
- Auto drilling tip that significantly increases drilling on harder wood.
- Cutting blade placed from the tip to the spiral groove for clean and precise cuts.

APPLICATIONS

Suitable for all types of wood on woodworking and construction jobs.

USE

Hex shank for manual drills with a 13 mm chuck.



Pcs.	Ø (mm)	TI (mm)	UI (mm)	Code
1	8	230	160	12.703
1	10	230	160	12.704
1	12	230	160	12.705
1	14	230	160	12.706
1	16	230	160	12.707
1	18	230	160	12.708
1	20	230	160	12.709

HARD METAL FORSTNER BIT FOR WOOD

FORSTNER BITS MADE OF CARBIDE MILLING CUTTER FOR WOOD



ADVANTAGES

- Forstner bit with tungsten carbide teeth (widia).
- Great cutting speed and lifespan.
- Double cutting blade, centering point and two external cutting teeth for an optimal drilling on hard wood.

APPLICATIONS

Suitable for door hinge fitting.

USE

Vástago cilíndrico para uso con taladro manual, de columna o fresadora.

Pcs.	mm	Ø (mm)	Code
1	26	9	12.877
1	35	9	12.710



WOOD COUNTERSINK BITS



ADVANTAGES

- HSS 3 Point spiral bits with centering tip and scaled blade for a precise and fast cut. Double spiral groove to improve sawdust removal.
- The countersink may be used as a depth regulator.
- Allows 6 - 8 & 10 mm countersinking.

APPLICATIONS

Suitable for drilling and countersinking on all types of wood.

USE

Cylindrical shaft for manual drill.

Set	Ø (mm)	Code
3	6, 8, 10	12.735



10-PIECE WOOD ROTARY RASP SET



MAIN ADVANTAGES

Material: Made of 45# carbon steel, heat-treated to provide an optimal balance of durability, hardness, and resistance to deformation.

High dimensional stability: The tools maintain their shape during use without bending or twisting, enabling precise and clean work.

Ergonomic design: Ø 6.3 mm cylindrical shank, compatible with most standard electric drills and rotary tools.

Clean cutting finish: The sharp, well-distributed teeth allow for controlled roughing and good surface quality.

Shank diameter: 1/4" or 6.30 mm



STAYER

ST GRINDING

Code: 1.4344

Code: 11.42

SDS PLUS (PRO4) BITS



ADVANTAGES

- **High quality hardened steel** with tungsten carbide tip.
- **4 tips "X" shaped point** to improve the bit's resistance and lifespan, allowing reinforced concrete drilling without getting stuck like **conventional drill bits** do.
- **Centering point** to improve the drilling precision.
- **Double channel spiral grooves** for an optimal dust extraction, reducing the bit's abrasion while **increasing the drilling speed**.
- **Optimal welded point to increase its resistance** increasing its lifespan while **decreasing drilling vibrations**.

APPLICATIONS

For masonry, concrete and reinforced concrete. Compatible with every drill and hammer with an SDS PLUS insertion.

4 Bits



Ø x Tl x Ul



Ø: (Diameter) Tl: Total length Ul: Use length.



Pcs.	Ø (mm)	Lt (mm)	Lu (mm)	Code
5	5	110	50	11.5739
5	6	110	50	11.5740
5	5	160	100	11.5741
5	6	160	100	11.5742
5	8	160	100	11.5743
5	10	160	100	11.5744

Ø (mm)	Tl (mm)	Ul (mm)	Code	Code	Minimum order
5	110	50	11.5703	11.1	5
6	110	50	11.5436	11.4	5
7	110	50	11.5840	11.68	5
8	110	50	11.5437	11.7	5
9	110	50	11.5841	11.69	5
10	110	50	11.5438	11.10	5

Ø (mm)	Tl (mm)	Ul (mm)	Code	Code	Minimum order
5	160	100	11.5704	11.2	5
6	160	100	11.5439	11.5	5
7	160	100	11.5842	11.70	5
8	160	100	11.5440	11.8	5
9	160	100	11.5843	11.71	5
10	160	100	11.5441	11.11	5
11	160	100	11.5844	11.72	5
12	160	100	11.5442	11.15	5
14	160	100	11.5852	11.19	5

Ø (mm)	Tl (mm)	Ul (mm)	Code	Code	Minimum order
5	210	150	11.6059	11.3	5
6	210	150	11.5443	11.6	5
8	210	150	11.5705	11.9	5
10	210	150	11.5706	11.12	5
12	210	150	11.5707	11.16	5
14	210	150	11.5444	11.20	5
16	210	150	11.5445	11.22	5

Ø (mm)	Tl (mm)	Ul (mm)	Code	Code	Minimum order
8	260	200	11.5895	11.73	5
10	260	200	11.5896	11.13	5
12	260	200	11.5897	11.17	5
14	260	200	11.5898	11.74	5
16	260	200	11.5899	891.342	5

Ø (mm)	Tl (mm)	Ul (mm)	Code	Code	Minimum order
10	310	250	11.5708	11.75	5
12	310	250	11.5709	12.201	5
14	310	250	11.5710	11.76	5
16	310	250	11.5711	12.202	5
18	310	250	11.5712	891.344	5
20	310	250	11.5713	891.345	5
22	310	250	11.5714	891.346	5
25	310	250	11.5715	12.203	5

Ø (mm)	Tl (mm)	Ul (mm)	Code	Code	Minimum order
10	450	400	11.5446	11.14	5
12	450	400	11.5447	11.18	5
14	450	400	11.5448	11.21	5
16	450	400	11.5449	11.24	5
18	450	400	11.5450	11.26	5
20	450	400	11.5451	891.347	5
22	450	400	11.5452	11.27	5
25	450	400	11.5453	11.28	5
28	450	400	11.5974	11.29	5
30	450	400	11.5975	11.30	5
32	450	400	11.5976	11.77	5

Ø (mm)	Lt (mm)	Lu (mm)	Cód.	Cód.
10	1000	915	11.5971	11.78
12	1000	915	11.5972	11.50
16	1000	915	11.5973	11.51

SDS PLUS (PRO 8) BITS

- Solid tungsten carbide (widia) full head.
- Directly welded to the drill bit body (not inserted), improving durability and power transmission.
- Higher resistance to heat and wear.
- Superior performance against steel rebar in reinforced concrete.
- 4-Cutter Geometry (Cross or "X" cut) to:
 - Prevent snagging on steel rebar.
 - Improve centering during drilling.
 - Produce rounder and more precise holes.
 - Increase penetration speed.
- SDS Plus Shank System
 - Standardized shank for SDS Plus rotary hammers.
 - Allows for quick, tool-free bit changes and optimal impact transmission.
- Flute Design
 - 4-flute design for rapid dust evacuation.
 - Optimized geometry to improve material extraction and reduce friction.
 - Extends the rotary hammer's service life and prevents drill bit overheating.
- Durability and Service Life
 - Longer service life compared to 2-cutter or inserted-head drill bits.
 - Better performance in intensive and repetitive tasks.
 - Designed for professional applications.



Applications:



Reinforced Concrete



Concrete



Stone



Brick



Cement

Ø (mm)	Lt (mm)	Lu (mm)	Code	Minimum order
5	110	50	11.6036	5
6	110	50	11.6037	5
8	110	50	11.6040	5

Ø (mm)	Lt (mm)	Lu (mm)	Code	Minimum order
6	160	100	11.6038	5
8	160	100	11.6041	5
10	160	100	11.6044	5
12	160	100	11.6047	5

Ø (mm)	Lt (mm)	Lu (mm)	Code	Minimum order
6	210	150	11.6039	5
8	210	150	11.6042	5
10	210	150	11.6045	5
12	210	150	11.6048	5
14	210	150	11.6050	5
16	210	150	11.6052	5

Ø (mm)	Lt (mm)	Lu (mm)	Code	Minimum order
8	310	250	11.6043	5
10	310	250	11.6046	5
12	310	250	11.6049	5
14	310	250	11.6051	5
16	310	250	11.6053	5

SDS MAX DRILL BITS (PRO4 / PRO5)



MAIN ADVANTAGES

- BHigh-quality hardened steel drill bit with tungsten carbide tip.
- 4-cutter head with "X" geometry to improve resistance, extend the drill bit's service life, and allow drilling into reinforced concrete without snagging, unlike conventional drill bits.
- Nickel coating.
- Centering tip to facilitate drilling.
- Double-flute design for optimal dust extraction
- Optimized tip welding to increase bit strength, extend its service life, and reduce vibrations during drilling.

APPLICATIONS

For masonry, concrete, reinforced concrete, and natural stone.

Compatible with all SDS MAX rotary hammers.

4 Cutters

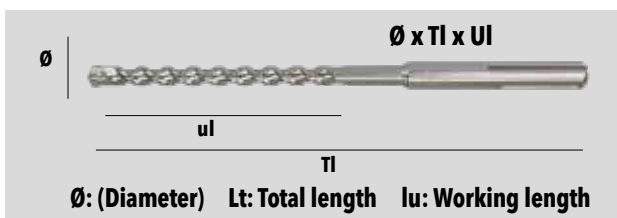

Ø (mm)	Lt (mm)	Lu (mm)	Code 	Code 	Minimum order
16	260	140	11.5429	12.205	5

Ø (mm)	Lt (mm)	Lu (mm)	Code 	Code 	Minimum order
12	340	200	11.5454	12.222	5
14	340	200	11.5455	12.208	5
16	340	200	11.5456	12.209	5
18	340	200	11.5457	12.210	5
20	340	200	11.5458	12.223	5
22	320	200	11.5900	12.224	5
24	320	200	11.5901	12.225	5
25	320	200	11.5902	12.216	5

Ø (mm)	Lt (mm)	Lu (mm)	Code 	Code 	Minimum order
14	380	260	11.5432	12.226	5
18	380	260	11.5433	12.227	5
20	380	260	11.5431	12.206	5
22	380	260	11.5428	12.228	5
25	380	260	11.5430	12.229	5
28	380	260	11.5434	12.207	5
32	380	260	11.5427	12.204	5

Ø (mm)	Lt (mm)	Lu (mm)	Code 	Code 	Minimum order
12	540	400	11.5459	12.230	5
14	540	400	11.5460	12.231	5
16	540	400	11.5461	12.232	5
18	540	400	11.5462	12.233	5
20	520	400	11.5463	12.211	5
22	520	400	11.5464	12.234	5
25	520	400	11.5465	12.212	5

Ø (mm)	Lt (mm)	Lu (mm)	Code 	Code 	Minimum order
18	600	450	11.5466	12.235	5
20	600	450	11.5467	12.236	5
22	600	450	11.5468	12.237	5
25	600	450	11.5469	12.238	5
28	600	450	11.5470	12.239	5
30	600	450	11.5471	12.213	5
32	600	450	11.5472	12.240	5
35	600	450	11.5473	12.214	5
40	600	450	11.5474	12.215	5
45	600	450	11.5961	12.217	5
50	600	450	11.5962	12.241	5

Ø (mm)	Lt (mm)	Lu (mm)	Code 	Code
18	1000	833	11.5964	12.242
20	1000	833	11.5965	12.243
22	1000	833	11.5966	12.244
25	1000	833	11.5967	11.31
32	1000	833	11.5968	11.32
38	1000	833	11.5969	12.245
40	1000	833	11.5970	11.33

SDS PLUS / SDS MAX CHISELS AND POINTERS



ADVANTAGES

- High quality tempered steel with hardening treatment to reduce wear and increase the tool's lifespan.
- Greater power and demolition speed.
- Greater material removal performance to increase the tool's lifespan.

APPLICATIONS

Refurbish and restoration jobs on masonry, concrete, bricks, floor and wall tiles. Compatible with every SDS PLUS insertion hammer.



Model	Width mm	Length mm	Code	Code
Pointed chisel	-	140	12.1307	11.34
Flat chisel	20	140	12.1308	11.35
Spade chisel	40	140	12.1309	11.36
Bush hammer		140	12.1261	11.39
Self-sharpening pointed chisel	-	280	12.947	891.473
Self-sharpening flat chisel	25	280	12.946	891.474
Spade chisel	40	250	12.948	11.37
Channeling chisel	14	250	12.393	891.476

SDS MAX POINTED AND FLAT CHISELS



ADVANTAGES

- High quality tempered steel with hardening treatment to reduce wear and increase the tool's lifespan.
- Greater power and demolition speed.
- Greater material removal performance to increase the tool's lifespan.

APPLICATIONS

Refurbish and restoration jobs on masonry, concrete, bricks, floor and wall tiles. Compatible with every SDS MAX insertion hammer.



Modelo	Width mm	Length mm	Code	Code
Self-sharpening pointed chisel	-	400	12.563	891.477
Self-sharpening pointed chisel	-	600	12.736	891.478
Self-sharpening flat chisel	25	400	12.564	891.479
Self-sharpening flat chisel	25	600	12.388	891.480
Spade chisel	50	400	12.396	891.481
Spade chisel	80	400	12.397	891.482
Brick channeling chisel	32	300	12.394	891.483
Winged channeling chisel	35	380	12.395	12.218
Pointed spade chisel	110	450	12.1312	11.47

SDS PLUS / SDS MAX ADAPTER

CHUCK ADAPTOR



	Inch	Ø (mm)	Code
Drill chuck adaptor	1/2"	Ø 13	11.788

ADAPTOR



		Code
Adapter	SDS MAX a SDS PLUS	891.485

HEX 30 POINTED AND FLAT CHISELS



MAIN ADVANTAGES

- High-quality tempered steel, hardened to reduce wear and extend its service life.
- High power and faster demolition speed.
- Higher material removal rate, increasing its service life.

APPLICATIONS

- For renovation or restoration work in masonry, concrete, wall and floor tiles, and brick.
- Compatible with all hammers with HEX 30 shank.

Material	Width mm	Length mm	Code	Code
Self-sharpening pointed chisel	-	400	12.260	891.486
Spade chisel	80	400	12.341	11.79
Self-sharpening flat chisel	26	400	12.1360	891.488
Straight hex spade chisel	135	440	12.1314	11.40

HEX 30 CHISELS AND POINTERS



ADVANTAGES

- High quality tempered steel with hardening treatment to reduce wear and increase the tool's lifespan.
- Greater power and demolition speed.
- Greater material removal performance to increase the tool's lifespan.

APPLICATIONS

For refurbish and restoration jobs on masonry, concrete, bricks, floor and wall tiles.
Compatible with every HEX 30 insertion hammer.

Crown	Metric	Ø (mm)	Code	Code
SDS-PLUS	M16	40	11.6029	12.190
SDS-PLUS	M16	50	11.6030	12.191
SDS-PLUS	M16	68	11.6031	12.192
SDS-PLUS	M16	82	11.6032	12.193

DRILLING CROWNS M16 SDS-PLUS

Core	Length	Code	Code
SDS-PLUS	110	11.6085	12.194
SDS-PLUS	160	11.6086	12.195
SDS-PLUS	440	11.6027	12.199
8x110 drill bit		11.5933	12.197

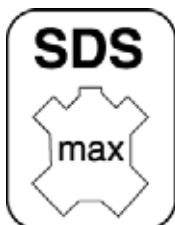

ADVANTAGES

- High quality tempered steel with hardening treatment to reduce wear and increase the tool's lifespan. Great broing speed
- Centering bit.
- Reinforced Widia teeth.

APPLICATIONS

Broing and drilling boring on masonry, concrete, bricks, floor and wall tiles.
Compatible with every **SDS MAX** insertion hammer.

Crown	Metric	Ø (mm)	Code
SDS-MAX	M22	80	11.5928
SDS-MAX	M22	100	11.5929
SDS-MAX	M22	120	11.5930

M22 SDS MAX CROWN SHAFTS



Crown Shaft	Width	Length	Code
Core	M22	400	11.5936
Centering drill bit	8	110	11.5933

SETS SDS-PLUS



SDS-PLUS	Ø	mm	Code
7 masonry bits set	5,6,8	110	11.5757
	6,8,10,12	160	



13 SDS-PLUS bits set	Width	Length	Code
Bits	6,8,10,12	160	11.5762
Bits	10,12,14,16	200	
Bits	10	260	
Chisel	20	250	
Spade	50	250	
Pointer	-	250	
Groover	-	250	

SDS-PLUS BITS STAND









Stand + Bits

Code 1.1269

Ø (mm) x L	Units	Code
5x110	10	11.5703
6x110	10	11.5436
8x110	10	11.5437
10x110	10	11.5438
6x160	10	11.5439
8x160	10	11.5440
10x160	10	11.5441
12x160	10	11.5442
10x210	6	11.5706
12x210	6	11.5707
14x210	6	11.5444
16x210	6	11.5445
10x310	6	11.5708
12x310	6	11.5709
14x310	6	11.5710
16x310	6	11.5711
18x310	6	11.5712
20x310	6	11.5713
22x310	6	11.5714
25x310	6	11.5715

MIXERS WHISKS

Model	Description	Insertion	Ø (mm)	Code
-	Mixing wisk for drill	Ø8	Ø80x40	11.5505
H2	Liquid and low viscous materials Mixes from the bottom to the top	M14	Ø 120	12.231
H2	 Liquid and low viscous materials Mixes from the bottom to the top	M14	Ø140	12.232
H2	 Liquid and low viscous materials Mixes from the bottom to the top	M14 (desmontable)	Ø140	12.485
H2	 Material líquido y poco viscosos Mezcla del material de arriba hacia abajo	M14	Ø160	12.527
H3	 Suitable for all densities and viscosities. Provides uniform bottom-up mixing and easily penetrates the material. 600 mm x 120 mm mixing paddle 15-25 kg capacity (15 kg for fresh mortar and 25 kg for more liquid or lower-viscosity materials). For a fresh mortar density of 2-2.2 kg/L, this equates to a volume of 6.82-7.5 L. For an average density of 1.1 kg/L (pure plaster + water, paints, and resins), the volume equates to 22.72 L.	M14	Ø120	12.887
H3	 Suitable for all densities and viscosities. Provides uniform bottom-up mixing and easily penetrates the material. 600 mm x 140 mm mixing paddle 25-40 kg capacity (25 kg for fresh mortar and 40 kg for more liquid or lower-viscosity materials). For a fresh mortar density of 2-2.2 kg/L, this equates to a volume of 11.36-12.5 L. For an average density of 1.1 kg/L (pure plaster + water, paints, and resins), the volume equates to 36.36 L.	M14	Ø140	12.233
H3	 For all densities and viscosities Evenly mixes the material from the bottom up and penetrates into the material.	M14	Ø160	12.234
H4	- Two opposing propellers. The lower one pushes downwards, and the upper one pushes upwards. Ideal for painting. Prevents splashing.	M14	Ø114	12.235
T3	- Combined spin whisk Increased mixing speed	M14	Ø170	12.444
WK3	DM1450 Combined rotating propeller Increased mixing speed	M18	Inf Ø95 Sup Ø120	12.538
-	DM1450 Combined spin helix adaptor	M18 - M14		12.295

Drill



H2



H3



H4



T3



WK3



Adaptor



WIDIA DISCS FOR CIRCULAR SAWS

WOOD

• Standard

Widia discs with ATB teeth. Standard quality wood cutting

Ø (mm) x L		Code
Ø140 x 20 - Z24	Standard wood cutting. Reduction flange from 20 to 16 mm	2.171
Ø150 x 20 - Z14	Standard wood cutting. Reduction flange from 20 to 16 mm	12.142
Ø150 x 20 - Z16	Standard wood cutting. Reduction flange from 20 to 16 mm	2.29
Ø150 x 20 - Z24	Standard wood cutting. Reduction flange from 20 to 16 mm	12.318
Ø160 x 20 - Z16	Standard wood cutting. Reduction flange from 20 to 16 mm	2.172
Ø160 x 20 - Z24	Standard wood cutting. Reduction flange from 20 to 16 mm	2.173
Ø165 x 20 - Z30	Standard wood cutting. Reduction flange from 20 to 16 mm	2.468
Ø180 x 30 - Z40	Standard wood cutting. Reduction flange from 30 to 20 & 16 mm	2.175
Ø184 x 30 - Z24	Standard wood cutting. Reduction flange from 30 to 20 & 16 mm	2.176
Ø184 x 30 - Z40	Standard wood cutting. Reduction flange from 30 to 20 & 16 mm	2.177
Ø190 x 30 - Z24	Standard wood cutting. Reduction flange from 30 to 20 & 16 mm	2.146
Ø190 x 30 - Z40	Standard wood cutting. Reduction flange from 30 to 20 & 16 mm	2.178
Ø200 x 30 - Z40	Standard wood cutting	2.470
Ø205 x 30 - Z24	Standard wood cutting	2.137
Ø205 x 30 - Z54	Standard wood cutting	12.66
Ø210 x 30 - Z24	Standard wood cutting	12.229
Ø210 x 30 - Z48	Standard wood cutting	2.471
Ø230 x 25.4 - Z24	Standard wood cutting	2.192
Ø230 x 30 - Z48	Standard wood cutting	2.218
Ø250 x 30 - Z48	Standard wood cutting	2.34
Ø300 x 30 - Z48	Standard wood cutting.	2.42
Ø300 x 30 - Z72	Standard wood cutting.	2.46
Ø315 x 30 - Z36	Standard wood cutting. - Anti nails disc	4006.59

• HQ y HQ Semi-silent

Widia discs with ATB teeth. HQ quality wood cutting

Ø (mm) x L		Code
Ø235 x 30 - Z24	HQ wood cutting. Semi-silent plate	2.472
Ø250 x 30 - Z48	HQ wood cutting.	2.149
Ø250 x 30 - Z60	HQ wood cutting. Semi-silent plate	2.473
Ø300 x 30 - Z72	Standard wood cutting. Semi-silent plate	2.751
Ø300 x 30 - Z96	Standard wood cutting. Semi-silent plate	2.752
Ø305 x 30 - Z72	Standard wood cutting. Semi-silent plate	2.475
Ø305 x 30 - Z96	HQ wood cutting.	12.107
Ø315 x 30 - Z72	Standard wood cutting. Semi-silent plate	2.493
Ø350 x 30 - Z108	HQ wood cutting.	12.41

Disc ATB Wood

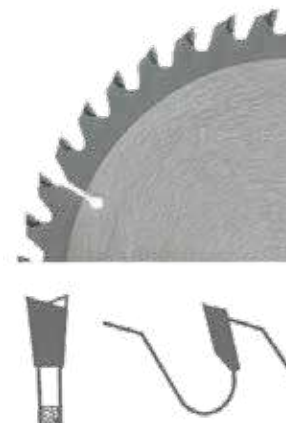

ATB teeth alternate upper bevel



Semi silent disc

WIDIA DISCS FOR CIRCULAR SAWS

LAMINATED

Cutting in MDF, plywood, chipboard, natural wood, etc...

• **HQ & Semi silent HQ**

Widia discs with TCG teeth for Laminated wood cutting

		Code
ø165 x 20 - Z42	HQ laminated wood cutting.	2.835
ø190 x 30 - Z48	HQ laminated wood cutting..	2.489
ø210 x 30 - Z48	HQ laminated wood cutting.	2.490
ø216 x 30 - Z48	HQ laminated wood cutting.	2.858
ø235 x 30 - Z48	HQ laminated wood cutting.	2.491
ø254 x 30 - Z80	HQ laminated wood cutting. Semi-silent plate	2.486
ø260 x 30 - Z80	HQ laminated wood cutting. Semi-silent plate	2.474
ø300 x 30 - Z96	HQ laminated wood cutting. Semi-silent plate	2.487
ø305 x 30 - Z96	HQ laminated wood cutting. Semi-silent plate	2.857
ø315 x 30 - Z48	HQ laminated wood cutting. Semi-silent plate	2.494



TCG teeth disc upper alternating bevel for laminated wood cutting.

ALUMINUM & METAL

• **Aluminum**

Widia discs with TCG teeth for Aluminum cutting

		Code
ø200 x 30 - Z60	Standard aluminum cutting.	2.120
ø205 x 30 - Z60	Standard aluminum cutting.	12.315
ø210 x 30 - Z60	Standard aluminum cutting.	2.138
ø250 x 30 - Z60	Standard aluminum cutting.	2.36
ø250 x 30 - Z80	HQ aluminum cutting.	2.154
ø250 x 30 - Z80	HQ aluminum cutting. Semi-silent plate	2.477
ø300 x 30 - Z96	HQ aluminum cutting. Semi-silent plate	2.753
ø300 x 30 - 120	HQ aluminum cutting. Semi-silent plate	12.893
ø305 x 30 - Z96	HQ aluminum cutting. Semi-silent plate	2.478
ø330 x 30 - Z100	HQ aluminum cutting.	12.44
ø350 x 30 - Z108	HQ aluminum cutting.	12.45



TCG Teeth

• **Metal**

Widia discs with TCG teeth for metal cutting

		Code
ø185 x 25.4 - Z48	HQ quality metal cut. Sandwich tooth. TD 185 disc - New*	12.931
ø185 x 25.4 - Z72	Corte INOX	12.977
ø230 x 25.4 - Z48	Standard metal cutting for CP 236	12.399
ø230 x 25.4 - Z60	Standard metal cutting for CP 236	75.510
ø230 x 25.4 - Z80	Standard metal cutting for CP 236	75.511
ø300 x 25.4 - Z60	HQ metal cutting	12.63
ø355 x 25.4 - Z80	HQ metal cutting	75.288
ø355 x 25.4 - Z72	HQ metal cutting. Diente sandwich. Disco de TD 355 B	12.660



TCG teeth disc upper alternating bevel for aluminum & metal

METAL CUTTING

TCG Widia Disc Sandwich teeth

ø 355 x 3.0 x 25.4 mm Z72

Code. 12.660

Over 10 times better performance over other widia discs



• **Sandwich Panel**

Widia MTCG Trapezium tooth blades Sandwich panels cutting

		Code
ø165 x 2.0 - Z30	Sandwich panel cutting. New*	20 2.816
ø190 x 2.0 - Z36	Sandwich panel cutting. New*	30 2.814
ø235 x 2.2 - Z50	Sandwich panel cutting. New*	30 2.817
ø300 x 2.2 - Z72	Sandwich panel cutting. New*	30 2.818



3-PIECE REDUCTION RING SET



Code: 12.1302



Code: 11.45



30 mm
30-22



25.4 mm
30-20



22 mm
30-16

CIRCULAR SAW DISCS

MULTIMATERIAL CUTTING DISCS

**MULTI MATERIAL CUTTING DISCS**

Wood, plastic, wood with nails, plaster cutting. Tungsten particle blade.
Perfect finish cuts on laminate.

Tool	Ømm	Code
	Ø 115 x 22.2	2.442
	Ø 125 x 22.2	2.455

TCT WIDIA SAW BLADE

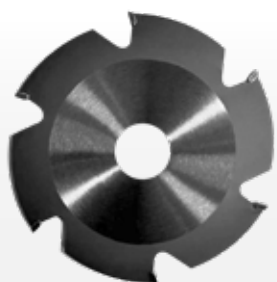
**TCT SAW BLADE**

Special blade for fast cutting of wood, PVC, and pipes.

Tool	Ømm	Number of teeth (Z)	Code
	Ø 115 x 22.2	6	2.874
	Ø 125 x 22.2	12	12.1356

HSS DISCS

**HSS DISC**

Specially designed for fast wood cutting.

Tool	Ømm	Grain	Code
	Ø 115 x 2 x 22.2	Z-4	2.196
	Ø 125 x 2 x 22.2	Z-4	2.197
	Ø230 x 2 x 22.2	Z-4	2.198

POLYCRYSTALLINE DIAMOND DISCS

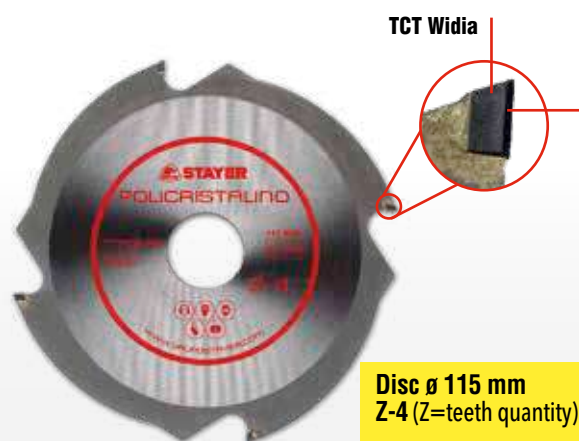

Disc Ø 115 mm
Z-4 (Z=teeth quantity)

Specially suited for Ø125 mm circular saws (CP 125)

Polycrystalline diamond

Polycrystalline Diamond Plate (PCD)
40 to 150 times higher performance than hard metal

Application

Furnitures / Coated or lacquered Doors and boards / Laminated parquet / MDF pieces (DM) whether or not coated / Soft and postforming

Ø	Ø	Segment thickness (mm)	Plate thickness (mm)	N° teeth (Z)	Code
115	22.2	1.7	1.2	Z-4	12.522
125	22.2	1.7	1.2	Z-4	12.523
190	30	1.7	1.2	Z-12	12.569

“ The cutting geometry of the polycrystalline diamond guarantees a clean cut and much better performance than traditional discs.
Reduces dust and sawdust. ”

MILLING CUTTER FOR WALL CHASER



Channel width 25mm
Diameter Ø78mm

Code:12.597

HARD METAL BURRS

3 PCS METAL BURRS



3 hard metal burrs for die grinders and drills (Mx according to DIN 8033)
 - Cylindrical burr
 - Ball burr
 - Ojive burr
 ø6mm shank.

Cross serrated surface (double edge).
Roughing and metal chips removal, edges, welding cords roughing, casting, tempered steel, hard plastics, Nickel alloys & titanium.

Ø x UI (mm)	Shank Ø (mm)	TI (mm)	Code
12x25	6	70	1.2365
12x10.8	6	55	
12x25	6	70	

5 PCS METAL BURRS



5 hard metal burrs for die grinders and drills (Mx according to DIN 8033)
 - Front cylindrical burr
 - Round cylindrical burr
 - Ball burr
 - Ojive burr
 - Conic burr
 ø6mm shank.

Cross serrated surface (double edge).
Roughing and metal chips removal, edges, welding cords roughing, casting, tempered steel, hard plastics, Nickel alloys & titanium.

5 Pcs set

Ø x UI (mm)	Shank Ø (mm)	TI (mm)	Code
12x25	6	70	1.2364
12x25	6	70	
12x25	6	70	
12x25	6	70	
12x10.8	6	55	

Front cylindrical burr



D = ø12 mm d = ø6 mm
 L = 70 mm l = 25 mm

Ball burr



D = ø12 mm d = ø6 mm
 L = 55 mm l = 10.8 mm

Ojive burr



D = ø12 mm d = ø6 mm
 L = 70 mm l = 25 mm

Round cylindrical burr



D = ø12 mm d = ø6 mm
 L = 70 mm l = 25 mm

Conic burr





D = ø12 mm d = ø6 mm
 L = 70 mm l = 25 mm

5-PIECE Reciprocating Saw Blade Set

*** SET 5 SAWS CUTTING ALL MIXED SAWS WOOD, PLASTER, PLASTIC, METAL**

Code: 12.630





Icons	Pcs.	Description	Applications	Size
 	1	BIM. Wave milled teeth. Fine clean cutting	Thin metal sheets (0.7-3mm). Thin profiles/pipes (<100mm). PVC.	150x19x0.9





Icons	Pcs.	Description	Applications	Size
	1	BIM. Wave milled teeth. Special demolition cut, Straight and fast metal and wood cutting	Wood, Wood with nails, Chipboard (<100 mm), Fibreglass, Plastic/epoxy, Solid (<100 mm), Wall, wood, metal cutting (<100 mm)	150x22x1.6





Icons	Pcs.	Description	Applications	Size
 	1	BIM. Side set milled teeth Special immersion cut Fast cutting wood & metal.	Wood, Wood with nails, Chipboard (10-100 mm), Fibreglass reinforcements & plastic, plastic/epoxy, Solid (8-50 mm), Drywall (<100 mm), Window frames: Wood & metal.	150x19x1.25

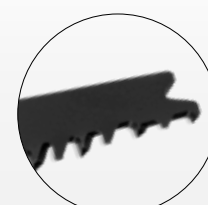

Icons	Pcs.	Description	Applications	Size
 	1	HCS. Rectified, side-set teeth, Progressive. Fine precision cut	Wood pannels (<175 mm). Wood de Construction (6-150 mm). Plywood, Chipboard, MDF (6-60 mm). PVC (6-150 mm).	200x19x1.25



Icons	Pcs.	Description	Applications	Size
 	1	HCS. Rectified, side-set teeth, Fine precision cut	Wood Plywood Plastic	240x19x1.5





3-PIECE Reciprocating Saw Blade Set

*** SET 3 SAWS HCS MIXED WOOD**



Code: 12.632

Includes adaptative fitting saw case



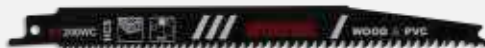

Icons	Pcs.	Description	Applications	Size
 	1	HCS. Rectified, side-set teeth. Fast cutting.	Wood <190mm Plywood. Plastic Branches.	240 x 19 x 1.5



Icons	Pcs.	Description	Applications	Size
 	1	HCS. Rectified, side-set teeth Progressive. Fine precision cut	Wood pannels (<175 mm). Construction wood(6-150 mm). Plywood. Chipboard. MDF (6-60 mm). PVC (6-150 mm).	240 x 19 x 1.5





Icons	Pcs.	Description	Applications	Size
  	1	HCS. Rectified, side-set teeth. Fine precision cut.	Wood (<100mm). MDF (<100 mm). Boards. Chipboard. Plywoods. PVC (<100 mm).	150 x 19 x 1.25

*** SET 3 HCS WOOD AND PRUNING SAWS**

Code: 12.629





Icons	Pcs.	Description	Applications	Size
 	3	HCS. Rectified, side-set teeth. Fast cutting.	Wood <190mm Plywood. Plastic Branches.	240 x 19 x 1.5

*** SET 3 HCS SAWS WOOD AND PLASTERBOARD**

Code: 12.762





Icons	Pcs.	Description	Applications	Size
  	3	HCS. Rectified, side-set teeth. Fine precision cut.	Wood (<100mm). MDF (<100 mm). Boards. Chipboard. Plywoods. PVC (<100 mm).	150 x 19 x 1.25

*** SET 3 BIM MIXED METAL BIM SAWS**



Code: 12.631

Includes adaptative fitting saw case



Icons	Pcs.	Description	Applications	Size
 	1	BIM. Double sided milled teeth. Fast cutting & long lifespan	Thin metal sheets & thick (1-8 mm), Strong profiles (<100 mm)	150 x 19 x 0.9



Icons	Pcs.	Description	Applications	Size
 	1	BIM. Double sided milled teeth. Fast cutting & flexible.	Thick metal sheets (3-8 mm). Profiles/pipes (<175mm).	225 x 19 x 0.9



Icons	Pcs.	Description	Applications	Size
	1	BIM. Wave milled teeth. Thin metal sheets easy cut.	Thin metal sheets (0.7-3 mm) Thin profiles/pipes (<100mm)	150 x 19 x 0.9

*** SET 3 BIM METAL SAWS**

Code: 12.763



Icons	Pcs.	Description	Applications	Size
	3	BIM. Wave milled teeth. Thin metal sheets easy cut.	Thin metal sheets (0.7-3 mm) Thin profiles/pipes (<100mm)	150 x 19 x 0.9

*** PALLETS (3 BLADES SET)**

Code: 12.719





Icons	Pcs.	Description	Applications	Size
 	3	BIM. Rectified, side-set teeth 175mm cutting length Teeth spacing 3.2/5mm Demolition progressive teeth for fast cuts.	Wood with nails/ metal (Wood, Boards Chipboard) (<175mm). GFX/Epoxi, solid (<175mm). Demolition	225 x 22 x 1.6

*** FROZEN GOODS (3 BLADES SET)**

Code: 12.500



Icons	Pcs.	Description	Applications	Size
  	3	Stainless steel	Frozen goods (10-250mm)	305 x 19 x 1.2

3-PIECE Reciprocating Saw Blade Set

*** PALLETS (2 BLADES SET)**

Code:12.1303



Icons	Pcs.	Description	Applications	Size
	2	<p>BIM. Rectified, side-set teeth 175mm cutting length</p> <p>Teeth spacing 3.2/5mm Demolition progressive teeth for fast cuts.</p>	<p>Wood with nails/metal (Wood, Boards Chipboard) (<175mm). GFX/Epoxi, solid (<175mm). Demolition</p>	225 x 22 x 1.6

*** SET 2 HCS WOOD AND PLASTERBOARD SAWS**

Code: 12.1305



Icons	Pcs.	Description	Applications	Size
	2	<p>HCS. Rectified, side-set teeth. Fine precision cut.</p>	<p>Wood (<100mm). MDF (<100 mm). Boards. Chipboard. Plywoods. PVC (<100 mm).</p>	150 x 19 x 1.25

*** SET 2 HCS WOOD AND PRUNING SAWS**

Code: 12.1304



Icons	Pcs.	Description	Applications	Size
	2	<p>HCS. Rectified, side-set teeth. Fast cutting.</p>	<p>Wood <190mm Plywood. Plastic Branches.</p>	240 x 19 x 1.5

*** SET 2 BIM METAL SAWS**

Code: 12.1306



Icons	Pcs.	Description	Applications	Size
	2	<p>BIM. Double sided milled teeth. Fast cutting & flexible.</p>	<p>Thick metal sheets (3-8 mm). Profiles/pipes (<175mm).</p>	225 x 19 x 0.9

Individual Reciprocating Saw Blades

WOOD & METAL (PALLET SPECIAL) TCT TEETH

Code: 12.634



Icons	Pcs.	Description	Applications	Size
	1	<p>HM. Widia teeth. Rectified, side-set teeth Long lifespan. Demolition teeth, Progressive spacing for fast cuts.</p>	<p>Wood with nails/ metal (hardened) (5-175mm). Wood with steel (5-175mm) Cast steel tubes (Ø-<6"). Fibreglass / epoxi (<175mm). Window frames metal/wood (<175mm)</p>	225x50x1.5

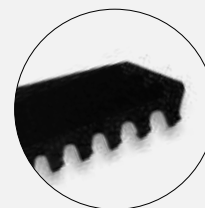

*** BRICKS Y FIBRECEMENT TCT TEETH**

Code:12.633



Icons	Pcs.	Description	Applications	Size
	1	<p>HM. Widia teeth. Long lifespan. Fast cutting on construction materials like bricks.</p>	<p>Medium bricks (< 215 mm) Poroton Fibrecement Porous concrete Red brick Construction stone</p>	305x50x1.5



SET 10 JIG SAW BLADES

SET 10 HARD/SOFTWOOD SAWS

Code: 12.627

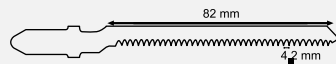

Includes adaptive fitting saw case



Icons	Pcs.	Description	Applications	Lu (mm)	TPI
ST125SF 	2	HCS. Fast cutting soft wood	Softwood (5-55mm)	100	4



Icons	Pcs.	Description	Applications	Lu (mm)	TPI
ST136CF 	2	HCS. Curved cut chipboard	Softwood (5-55mm), Wood Chipboard	100	4



Icons	Pcs.	Description	Applications	Lu (mm)	TPI
ST125FH 	2	HCS. Fast cutting laminate and hardwood	Softwood (5-55mm), Chipboard	100	4



Icons	Pcs.	Description	Applications	Lu (mm)	TPI
ST114SC 	2	HCS. Clean cut agglomerate	Laminate, MDF, Plywood	82	4.2



Icons	Pcs.	Description	Applications	Lu (mm)	TPI
ST113CC 	2	HCS. Curved cut clean laminated	Hardwood, Chipboard, Laminate, Plywood	100	4

*** SET 10 SAWS WOOD, METAL AND ALUMINUM**

Code: 12.628

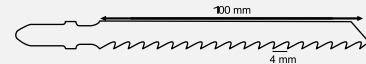

Includes adaptive fitting saw case



Icons	Pcs.	Description	Applications	Lu (mm)	TPI
ST125SF 	2	HCS. Fast cutting of soft wood.	Wood	100	4



Icons	Pcs.	Description	Applications	Lu (mm)	TPI
ST101C 	2	HCS. Curved wood cut.	Wood	82	2



Icons	Pcs.	Description	Applications	Lu (mm)	TPI
ST114SC 	2	HCS. Clean cut chipboard	Wood	100	2.5



Icons	Pcs.	Description	Applications	Lu (mm)	TPI
ST207SC 	2	HSS. Clean metal cutting	Metal	91	1.2



Icons	Pcs.	Description	Applications	Lu (mm)	TPI
ST208SF 	2	HSS. Fast clean cut aluminum	Aluminium	100	3

*** SET 10 WOOD SAWS (STRAIGHT AND CURVED CUT)**

Code: 12.626

Includes adaptive fitting saw case

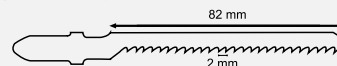

Icons	Pcs.	Description	Applications	Lu (mm)	TPI
ST102F 	4	HCS. Clean cut	Wood	92	2



Icons	Pcs.	Description	Applications	Lu (mm)	TPI
ST100S 	4	HCS. Fast cutting.	Wood	82	2



Icons	Pcs.	Description	Applications	Lu (mm)	TPI
ST101C 	2	HCS. Curved cut	Wood	100	3

SET 5 JIG SAW BLADES

*** SET 5 HCS WOOD ST 125 SF**

Code: 12.880

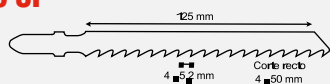

Icons	Pcs.	Description	Applications	Lu (mm)	TPI
	5	HCS. Fast cutting wood	Softwood (4-50mm)	125	4-5.2

*** SET 5 HCS WOOD ST 125 FH**

Code: 12.881



Icons	Pcs.	Description	Applications	Lu (mm)	TPI
	5	HCS. Precise and clean cut soft wood	Softwood (3-30mm)	125	2.7

*** SET 5 HCS HARDWOOD ST 300 HF**

Code: 12.882



Icons	Pcs.	Description	Applications	Lu (mm)	TPI
	5	HCS. Precise cutting hardwood	Hardwood (10-65mm)	300	3

*** SET 5 BIM WOOD ST 152 FH**

Code: 12.883



Icons	Pcs.	Description	Applications	Lu (mm)	TPI
	5	BIM. Fast cutting hardwood	Wood (5-100mm)	152	6

*** SET 5 HCS WOOD ST 113 CC**

Code: 12.884



Icons	Pcs.	Description	Applications	Lu (mm)	TPI
	5	HCS. Curved cut laminated	Hardwood (1.5-15mm)	113	18

*** SET 5 SAWS WOOD, METAL AND ALUMINUM**

Code: 12.1281

Includes adaptive fitting saw case



Icons	Pcs.	Description	Applications	Lu (mm)	TPI
	1	HCS. Fast cutting of soft wood.	Wood	100	4



Icons	Pcs.	Description	Applications	Lu (mm)	TPI
	1	HCS. Curved wood cut.	Wood	82	2



Icons	Pcs.	Description	Applications	Lu (mm)	TPI
	1	HCS. Clean cut chipboard	Wood	100	2.5



Icons	Pcs.	Description	Applications	Lu (mm)	TPI
	1	HSS. Clean metal cutting	Metal	91	1.2



Icons	Pcs.	Description	Applications	Lu (mm)	TPI
	1	HSS. Fast clean cut aluminum	Aluminium	100	3

SET 3 JIG SAW BLADES

*** SET 3 METAL SAWS (CURVED CUTTING)**

Code: 12.624



Icons	Pcs.	Description	Applications	Lu (mm)	TPI
ST207CC 	3	HSS. Curved cut	Thin sheet (1-3mm)	80	1.2

*** SET 3 SAWS BIM METAL AND ALUMINUM**

Code: 12.625

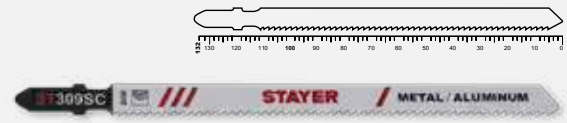

Icons	Pcs.	Description	Applications	Lu (mm)	TPI
ST309SC 	3	BIM. Bimetallic blades durable and breakage resistant to breakage. Straight and fast cutting.	Materials with fillers, aluminum, non-ferrous metals, ferrous metals, epoxy	132	2

SET 2 JIG SAW BLADES

*** SET 2 WOOD SAWS**

Code: 12.1274



Icons	Pcs.	Description	Applications	Lu (mm)	TPI
ST125SF 	2	HCS. Fast cutting of soft wood.	Wood	100	4

*** SET 2 METAL SAWS (CURVED CUTTING)**

Code: 12.1280



Icons	Pcs.	Description	Applications	Lu (mm)	TPI
ST207CC 	2	HSS. Curved cut	Thin sheet (1-3mm)	80	1.2

*** SET 2 HCS ST 300 HF HARDWOOD**

Code: 12.1276



Icons	Pcs.	Description	Applications	Lu (mm)	TPI
ST300HF 	2	HCS. Precise cutting hardwood	Hardwood (10-65mm)	300	3

*** SET 2 BRICK AND FIBER CEMENT SAWS**

Code: 12.1293



Icons	Pcs.	Description	Applications	Lu (mm)	TPI
ST341HM 	2	HM Bricks and Fiber Cement	Gypsum board (5-30mm) Reinforced plastics. Fiberglass Fiber cement boards (5-50mm)	100	6

*** SET 2 HCS WOOD**

Code: 12.1279

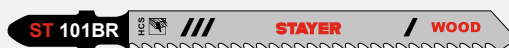

Icons	Pcs.	Description	Applications	Lu (mm)	TPI
ST101BR 	2	HCS. Fast wood cutting Reverse tooth	Wood	74	10













*** SET 2 SANDWICH PANEL SAWS**

Code: 12.1294



Icons	Pcs.	Description	Applications	Lu (mm)	TPI
ST318PS 	2	38 BIM. Fiber cement and gypsum boards.	Sandwich panel Construction timber with nails (< 65mm) Metal sheet, Tubes and profiles, including aluminum (Ø < 65 mm)	130	14-10

BANDSAW

Model	Description	Code
SN 1435 B	Belt saw 1435 P 6/10	2.267
SN 1435 B	Belt saw 1435 P 8/12	2.268
SN 1435 B	Belt saw 1435 P 10/14	2.269
SN 1470	Belt saw 1470x13x0.65mm P6/10	2.130
SN 1470	Belt saw 1470x13x0.65mm P8/12	2.117
SN 1470	Belt saw 1470x13x0.65mm P10/14	12.117
SN 1735	Belt saw 1735x13x0.65mm P6/10	2.208
SN 1735	Belt saw 1735x13x0.65mm P8/12	2.194
SN 1735	Belt saw 1735x13x0.65mm P10/14	12.366
SIENA 210	Belt saw 2110x20x0.90mm P8/12 	1047.13
SIENA 210	Belt saw 2110x20x0.90mm P10/14 	1047.14
SIENA 270	Belt saw 2450x27x0.90mm P4/6 	40.106
SIENA 270	Belt saw 2450x27x0.90mm P6/10 	40.73
SIENA 270	Belt saw 2450x27x0.90mm P8/12 	40.74
SIENA 270	Belt saw 2450x27x0.90mm P10/14 	40.75
SIENA 320	Belt saw 2680x27x0.90mm P4/6 	1047.26
SIENA 320	Belt saw 2680x27x0.90mm P6/10 	1047.3
SIENA 320	Belt saw 2680x27x0.90mm P8/12 	1047.4
SIENA 320	Belt saw 2680x27x0.90mm P10/14 	1047.5
SIENA 370	Belt saw 3160x27x0.90mm P4/6 	1047.19
SIENA 370	Belt saw 3160x27x0.90mm P6/10 	1047.25
SIENA 370	Belt saw 3160x27x0.90mm P8/12 	1047.20

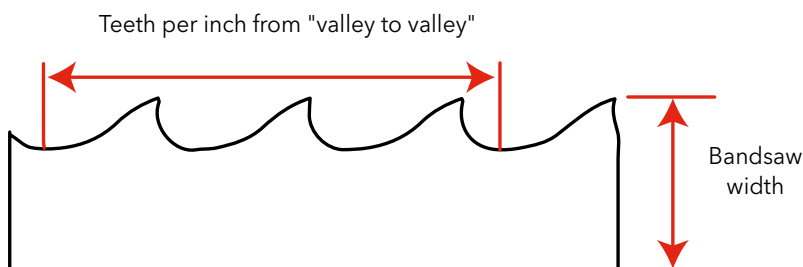

DIE ROUTER BITS

Duras



6 die router bits set with 6mm shaft.
 Wood routing, made of carbon steel and high performance double width.
 High wear resistance for a long lifespan.
 Suitable for all kinds of wood.
 Designed for evening, routing and kitchen assembly.
8 mm insertion, Check availability

Icon	N°	Insertion "d" (mm)	Diameter "D" (mm)	Length "B" (mm)	TI "L" (mm)	Code "d 6"
	1	6	4	11	51	1.2462
	2	6	6	19	51	
	3	6	8	19	51	
	4	6	10	19	51	
	5	6	12 hollow	12	38	
	6	6	14 hollow	12	38	



2 hollow bits of 12 & 14mm, reinforced.

Faster routing
 More material removal



N°	Insertion "d" (mm)	Diameter "D" (mm)	Length "B" (mm)	TI "L" (mm)	Code "d 8"
1	8	4	11	51	1.2620
2	8	6	19	51	
3	8	8	19	51	
4	8	10	19	51	
5	8	12 hollow	12	38	
6	8	14 hollow	12	38	

10 die router bits set with 6mm shaft.

10 die router bits set with 6mm shaft.
 Wood routing, made of carbon steel and high performance double width.
 High wear resistance for a long lifespan.
 Suitable for all kinds of wood.
 Designed for evening, routing and kitchen assembly.

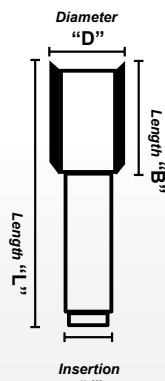

Icon	N°	Insertion "d" (mm)	Diameter "D" (mm)	Length "B" (mm)	TI "L" (mm)	Code
	1	6	3	11	51	1.2366
	2	6	4	11	51	
	3	6	5	11	51	
	4	6	6	19	51	
	5	6	8	19	51	
	6	6	10	19	51	
	7	6	12	19	51	
	8	6	14	19	51	
	9	6	18	19	51	
	10	6	12.7	25.4	63	

12 mixed router bits set (die bits & shaped bits) for an optimal finish on hard wood, soft wood and wood compounds.
 Different shapes for different bevel patterns.
 Suitable for assemblers, carpenters and construction workers.
 Suitable for any router with a 6mm insertion.
 Long lifespan.
 Carbon steel bit with high performance width.

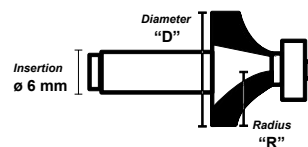

N°	Insertion "d" (mm)	Diameter "D" (mm)	Radius "R"	Code
1	6	12.7	6.35	1.351
2	6	22	6.35	
3	6	12.7	-	
4	6	32	-	
5	6	12.7	-	
6	6	16	-	
7	6	22	6.35	
8	6	12	-	
9	6	6	-	
10	6	28.6	9.5	
11	6	12.7	-	
12	6	25.4	4	

N°	Insertion "d" (mm)	Diameter "D" (mm)	Radius "R"	Code
1	8	12.7	6.35	1.2738
2	8	22	6.35	
3	8	12.7	-	
4	8	32	-	
5	8	12.7	-	
6	8	16	-	
7	8	22	6.35	
8	8	12	-	
9	8	6	-	
10	8	28.6	9.5	
11	8	12.7	-	
12	8	25.4	4	

COLLET & NUTS FOR ROUTERS



Tool	Contains	Width	Code
PR 10	Collet + nut	6 mm	12.491
PR 10	Collet + nut	6.3 mm	12.492
PR 10	Collet + nut	8 mm	12.493
PR 10	Collet + nut	10 mm	12.494
PR 10	Collet + nut	12 mm	12.495
PR 10	Collet + nut	12.7 mm	12.496
PR 6	Nut		5019.435
PR 6	Collet		5019.436

PLANNER BLADES



Set	Width	Code
2	82 mm	12.195
2	110 mm	12.605

- Carbide reversible blades for electric planer.
- Suitable for 82mm - 3 1/4" planers (cod. 12.195).
- Suitable for 110mm - 4 3/8" planers (cod. 12.605).
- Always use eye and hands protection. Follow your electric planer users manual instructions.
- Each blade has 2 cutting edges that may inverted. When both edges are blunt the blade must be replaced. This blades are not suitable for resharpening.
- To replace the tool blades plug it out from the power socket. Loosen the 2 screws holding the blade and slide the drum sideways.
- Always avoid touching the edges with your fingers.
- Once the screws have been loosened the blade may be stuck due to dust or work pressure. Use a wood chunk to hit the blade to unblock it.

BISCUIT JOINTER ACCESSORIES



	Diameter	Code
Disc TCT Z6	Ø 100x4x22mm	12.286



Set	Biscuit	Grain	Code
100	Wood	20	11.2493
100	Wood	10	11.2494
100	Wood	0	11.2495

OSCILLATING MULTI TOOL ACCESSORIES

Immersion die saw HCS

- Immersion die saw HCS (High Carbon Steel) for oscillating multi tools.
- Flat open insertion, easy and quick tool coupling with no other tools needed.
- Compatible with most of the main brands.
- Specially designed for Wood, plastic & drywall cutting. For

deep cuts, for reducing, opening holes and grounded cuts.
- Sizes 32 x 40 x 90 mm.

Code:12.548



Semi circular saw HCS

- Semi circular saw HCS (High Carbon Steel) for oscillating multi tools.
- Flat open insertion, easy and quick tool coupling with no other tools needed.
- Compatible with most of the main brands.
- Specially designed for Wood, plastic & drywall cutting.

Specially suited for hard to reach areas, grounded cuts, and edge cutting.
- Sizes 88 x 65 mm.

Code:12.550



Immersion die saw BIM

- Immersion die saw BIM (Bimetallic) for oscillating multi tools.
- Flat open insertion, easy and quick tool coupling with no other tools needed.
- Compatible with most of the main brands.
- Specially designed for metal, wood with nails, plastic and hard woods. For

deep cuts, for reducing, opening holes and grounded cuts.
- Sizes 32 x 40 x 90 mm.

Code:12.549



Semi circular saw BIM

- Semi circular saw BIM (Bimetallic) for oscillating multi tools.
- Flat open insertion, easy and quick tool coupling with no other tools needed.
- Compatible with most of the main brands.
- Specially designed for metal, wood

with nails, plastic and hard woods. Specially suited for hard to reach areas, grounded cuts, and edge cutting.
- Sizes 88 x 65 mm.

Code:12.551



Diamond die saw

- Diamond die saw for oscillating multi tools.
- Flat open insertion, easy and quick tool coupling with no other tools needed.
- Compatible with most of the main brands.
- Specially designed for tiles, ceramic materials & glass cutting.

For deep cuts, for reducing, opening holes and grounded cuts.
- Sizes 20 x 32 x 85 mm.

Code:12.553



Semi circular diamond saw

- Diamond edge semi circular saw for oscillating multi tools.
- Flat open insertion, easy and quick tool coupling with no other tools needed.
- Compatible with most of the main brands.
- Specially designed for tiles, ceramic materials & glass cutting.

Specially suited for hard to reach areas, grounded cuts, and edge cutting.
- Sizes 88 x 65 mm.

Code:12.554



Self adhering delta plate

- Self adhering plate for oscillating multi tools.
- Flat open insertion, easy and quick tool coupling with no other tools needed.
- Compatible with most of the main brands.

- Specially designed to be used as a delta sanding sheet support to sand wood, plastics & metals. The delta shape allows hard to reach and edges sanding.
- Sizes 93 x 93 x 93 mm

Code:12.557



Diamond delta plate

- Diamond delta plate for oscillating multi tools.
- Flat open insertion, easy and quick tool coupling with no other tools needed.
- Compatible with most of the main brands.
- Specially designed for ceramic materials, masonry and hard adhesive materials sanding.

- For edge sanding, plaster and mortar polishing. The delta shape allows hard to reach and edges sanding.
- Sizes 78 x 78 x 78 mm

Code:12.555



Scraper

- Scratching scraper for oscillating multi tools.
- Flat open insertion, easy and quick tool coupling with no other tools needed.
- Compatible with most of the main brands.
- Specially designed to scratch, tear off and strip. Remover silicon, glue, old paint or carpet.
- **Sizes 52 x 50 x 95 mm**

Code:12.552



Tungsten Carbide Plunge Cut Saw Blade For Nails And Nail-Embedded Wood

Code: 12.1355

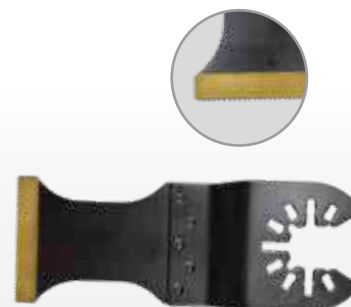

Set de Sanding sheets Delta autoadherentes

- Specially designed to be attached to a delta plate to sand woods & plastics.
- Delta shape allows for corners and edge sanding.
- Compatible with MULTITOOL PRO300, MULTI L20 & MULTI L18 from STAYER
- **Sizes 93 x 93 x 93 mm**



Model	Pcs.	Grain	Code
Multi Tool	10	40x2 - 60x3 - 80x3 - 120x2	12.556
	5	60	12.814
	5	80	12.815
	5	120	12.816
	5	180	12.817

Tiling set (4 Pcs)

- 4 Accessories set for oscillating multi tools specially suited for tiling.
- Flat open insertion, easy and quick tool coupling with no other tools needed.
- Compatible with most of the main brands.
- **Scraper (52 x 49 x 99 mm):** Specially designed to scratch, tear off and strip. Remover silicon, glue, old paint or carpet.
- **Diamond delta plate (73 x 73 mm):** Specially designed for ceramic materials, masonry and hard adhesive materials sanding.
- For edge sanding, plaster and mortar

- polishing. The delta shape allows hard to reach and edges sanding.
- **Diamond die saw (20 x 32 x 85 mm):** Specially designed for tiles, ceramic materials & glass cutting. For deep cuts, for reducing, opening holes and grounded cuts.
- **Diamond edge semi circular saw (88 x 55 mm):** Specially designed for tiles, ceramic materials & glass cutting. Specially suited for hard to reach areas, grounded cuts, and edge cutting.



Code:12.556

Code: 12.558

Wood & Drywall (4 Pcs)

- 4 Accessories set for oscillating multi tools specially suited for wood and drywall.
- Flat open insertion, easy and quick tool coupling with no other tools needed.
- Compatible with most of the main brands.
- **Scraper (52 x 49 x 99 mm):** Specially designed to scratch, tear off and strip. Remover silicon, glue, old paint or carpet.
- **Immersion die saw BIM (32 x 40 x 90 mm):** Specially designed for metal, wood with nails, plastic and hard woods. For deep cuts, for reducing, opening holes and grounded cuts.
- **Immersion die saw HCS (32 x 40 x 90 mm):**

- Specially designed for wood, plastic & drywall cutting. For deep cuts, for reducing, opening holes and grounded cuts.
- **Semi circular saw HCS (88 x 65 mm):** Specially designed for Wood, plastic & drywall cutting. Specially suited for hard to reach areas, grounded cuts, and edge cutting.



Code:12.559

MULTIDRILL ACCESSORIES

ROUGHING & CUTTING



Rotary precision drill accessories set.
180 Pcs for all kinds of jobs, cutting, polishing, sanding, brightening, etc...on any kind of surface and material.
Easy and quick accessory exchange.
Ø 3.10mm shaft.

Set 180 piezas		Code
x 10	Sanding rolls (Grain)	1.891
x 1	Felt plate 25.4x3.2 mm	
x 1	Felt roll	
x 4	Felt wheel	
x 1	Felt wheel 9.5x19 mm	
x 2	Sanding roll shafts	
x 4	Diamond bits	
x 1	HSS cylindrical drill bit	
x 3	Aluminum oxide wheel with shank	
x 6	Aluminum oxide grindstone	
x 2	Silicon carbide grindstone with shank	
x 6	Silicon carbide grindstone	
x 2	Nylon brushes	
x 3	Stainless steel brushes	
x 1	Brass brush	
x 1	Waxing / polishing compound	
x 30	Cutting discs 24x0.8 mm	
x 46	Cutting discs 24x0.4 mm	
x 45	Sanding discs	
x 3	Chromed shafts (3.2 / 2.4 / 1.6)	
x 1	Cutting disc shaft	
x 1	Felt wheel shaft	
x 1	Felt wheel shaft	
x 2	Fibreglass abrasive cutting discs	
x 1	Key 9.5 mm	
x 1	Flap wheel with shaft 32x9.5 mm	
x 1	Silicon carbide cated sharpening stone	

Sanding & Roughing

Code:1.2330



Rotary precision drill accessories set.
40 Pcs for sanding & roughing on different materials (wood , metal, etc...)
Perfect finish on multiple surfaces.
Small size case for an easy and comfortable storage and transportation.
Ø 3.10mm shaft diameter

40 pcs set

x 4	Cutting discs	Ø 3.2 mm
x 10	Sanding rolls	12.7 mm
x 1	Sanding shaft	Ø 3.2 mm
x 1	Roll shaft	Ø 3.17 mm
x 4	Abrasive points	20x3.2 mm
x 20	Sanding discs	

MULTIDRILL ACCESSORIES

Cutting

Code:1.2328



Rotary precision drill accessories set.
Specially assembled for cutting different types of materials. (wood, metal & construction materials).
Small size case for an easy and comfortable storage and transportation.
89 Pcs set.
Ø3.10mm shaft diameter

89 pcs set

x 1	Diamond disc	22x0.6 mm
x 1	Saw blade	22x0.3 mm
x 18	Fiber glass disc	32x1.2 mm
x 2	Cutting disc	32x1.6 mm
x 36	Cutting disc	24x0.6 mm
x 30	Cutting disc	24x0.8 mm
x 1	2 pieces shaft	Ø 3.17 mm

Cutting & Roughing

Code:1.2327



Rotary precision drill accessories set.
Specially assembled for cutting and roughing different types of materials.
Its wide array of components makes this set suitable for all types of surfaces with a great finish.
Ø3.10mm shaft

102 Pcs set

x 3	Aluminum oxide points
x 3	Silicon carbide points
x 6	Nickel & rubber points
x 3	Roughing discs
x 3	Sanding discs
x 6	Rubber sanding discs
x 40	Sanding sheets 20 mm
x 36	Cutting discs 24 mm
x2	Shaft

Polishing

Code:1.2329



Rotary precision drill accessories set.
Specially designed for cleaning and polishing any kind of material.
Includes polishing compound for a perfect finish.
Quick tool change with great precision on any area of work.
Ø 3.10mm shaft.

20 pcs set

x 4	Brush	Ø3.2 mm
x 3	Felt disc	25x6.3 mm
x 6	Felt disc	12.7x6.3 mm
x 2	Rubber support	22x3 mm
x 1	Polishing wheel	
x 1	Felt polishing wheel	
x 1	Polishing compound	
x 1	Sanding discs shaft	Ø 3.17 mm
x 1	Felt discs shaft	Ø 3.17 mm

SILICON CARBIDE ROLL

- 100 x 100 x 19 mm roller for metal cleaning, removal of rust and paint as well as burrs. Especially suitable for preparing metals for welding, anodizing or zinc plating.
- Large sanding surface, specially designed for demanding work on large surfaces, leaving a clean and uniform finish.
- Compatible with M8 insert sanding machines.
- Manufactured with a nylon fiber structure reinforced with silicon carbide (SiC), the main advantage of these discs lies in their flexibility, generating less temperature when applied on materials.



Dimensions	Code
100 x 100 x 19	12.862

BRASS WIRE ROLL

- 100 x 100 x 19 mm roller for wood graining, rust removal and metal polishing.
- Large sanding surface, specially designed for demanding jobs on large surfaces, leaving a clean and uniform finish.
- Brass plated steel wires, with medium hardness and high polishing and graining capacity. Brass ensures that the brush does not spark and gives a smoother and more polished finish than steel.
- Compatible with M8 insert polishers.



Dimensions	Code
100 x 100 x 19	12.863

NYLON ROLL

- 100 x 100 x 19 mm roller for wood structuring and texturing, rust removal and grain highlighting.
- Large sanding surface, specially designed for demanding jobs on large surfaces, leaving a clean and uniform finish.
- Nylon filaments with coarse aluminum oxide abrasive grit. The filaments are flexible, allowing access to all types of angles in irregular pieces, without scratching the surface or altering the dimensions of the piece.
- Compatible with M8 insert polishers.



Dimensions	Code
100 x 100 x 19	12.864

ABRASIVE AND LAMINATED ROLL

- Efficient material removal.
 - Provides uniform finish.
 - Fits any 19mm shaft diameter glazing machine.
 - Long roller life.
 - Sand and polish at the same time.
 - For polishing / sanding on flat surfaces.
- Whether metallic, such as stainless steel, brass, copper etc... and on wood and plastics.



Sizes	Dimensions	Code
ABRASIVE ROLL		
Fine	105x100x19	8180.150
Coarse	105x100x19	8180.151
LAMINATED ABRASIVE ROLL		
Fine	105x100x19	8180.152
Coarse	105x100x19	8180.153

BRASS WIRE BRUSH

For grinder.l. Ø 150mm, shaft 150x20.

Code: 5025.147



WIRE CUP BRUSH

Brush with medium abrasive grade, specially indicated for polishing and finishing operations. It presents an excellent performance in deburring, removing rust and paint.

The brass wires are more flexible, which facilitates the access to narrow or difficult to reach areas.

Code: 12.865



TWISTED WIRE BRUSH

- Twisted wire brush in cup (12. 866): brush with coarse abrasive grade, especially suitable for deburring operations on large surfaces. It has a high starting capacity and excellent performance at high revolutions.

- Flat twisted wire brush (12. 867): brush with coarse abrasive grade, especially suitable for deburring and cleaning operations on welds and forgings. Optimal for retreading and glass recovery.

Ø (mm)	Code
65	12.866
100	12.867



CLEANING DISCS

CLEAN STRIP SILICON CARBIDE DISCS

Fast cleaning to be used with M14 grinder

Dimensions	Code
115 x 22	12.860
125 x 22	12.861



FLAPS WHEELS

FLAPS WHEEL

Abrasive flap wheels made of high-performance aluminum oxide.

High flexibility to adapt to sanding on any surface.

Accessory for polishing and grinding weld seams, cutting burrs, metal profiles, and pipes.

Suitable for Inox (Stainless Steel), Aluminum, Wood, Plastics, and stone of medium hardness and abrasiveness.

Each flap wheel features 80 flaps and a Ø 6 mm shank.

Available in 2 sizes and 3 grit types.



Dimensions	Ø (mm)	Grain	Max. RPM	Pcs.	Code
60 x 30	6	60	25.000	10	12.617
60 x 30	6	80	25.000	10	12.618
60 x 30	6	120	25.000	10	12.619
40 x 20	6	60	25.000	10	12.614
40 x 20	6	80	25.000	10	12.615
40 x 20	6	120	25.000	10	12.616



PINK CORUNDUM MOUNTED BITS

PINK CORUNDUM MOUNTED BITS

For grinding, polishing, deburring of all types of ferrous materials.

Code
1.2367

Head x Usable Length x Total Length
Stem Diameter x Grain



- 16x32x40
6 x 46
- 25x25x40
6 x 36
- 20x32x40
6 x 36
- 25x25x40
6 x 36
- 16x32x40
6 x 46

ABRASIVE SANDPAPERS

Ø115 DISC



Pcs.	Ø (mm)	Grain	Holes	Code
5	115	40	8	12.822
5	115	60	8	12.823
5	115	80	8	12.824
5	115	120	8	12.825
5	115	180	8	12.826



Ø125 DISC



Model	Pcs.	Ø (mm)	Grain	Holes	Code
LOM L20 RO 125 LR 125 C	5	125	40	8	12.677
	5	125	60	8	12.678
	5	125	80	8	12.679
	5	125	120	8	12.680
	5	125	180	8	12.827
	10 mixed	125	2x40-3x60 3x80-2x120	8	12.676



Ø150 DISC



Model	Pcs.	Ø (mm)	Grain	Holes	Code
R0150 R0752	5	150	40	6	12.828
	5	150	60	6	12.829
	5	150	80	6	12.830
	5	150	120	6	12.831
	5	150	180	6	12.832
	10 mixed	150	2x40-3x60 3x80-2x120	6	12.681



Ø150 DISC



Model	Pcs.	Ø (mm)	Grain	Holes	Code
R05 Brushless	5	150	40	15	12.609
	5	150	60	15	12.610
	5	150	80	15	12.611
	5	150	120	15	12.612
	5	150	240	15	12.613



Ø180 DISC

Model	Pcs.	Ø (mm)	Grain	-	Code
HP750BE LU260C	5	180	24	Special goteleé	12.471
	5	180	40		12.833
	5	180	60		12.834
	5	180	80		12.835
	5	180	100		12.873
	5	180	120		12.843
	5	180	220		12.474
	5	180	multi 1x24,2x60, 1x100,1x240)		12.451



Ø225 DISC

Model	Pcs.	Ø (mm)	Grain	-	Code
HP1010 LP710E LP1000 LP700	5	225	24	Special goteleé	12.470
	5	225	40		12.836
	5	225	60		12.467
	5	225	80		12.837
	5	225	100		12.468
	5	225	120		12.838
	5	225	220		12.469
	5	225	mixed 1x24,2x60, 1x100,1x240)		220.163



ABRASIVE MESH DISCS

Ceramic grain mesh sanding discs.

Compatible with any disc sander thanks to its multiple holes that provide an optimal dust extraction.

Up to 4 times longer lifespan over regular sanding discs.

Significantly less dust production than regular sanding discs, less harmful for the user's health. Specially suited for wall sanding because they don't clog, and bodywork, thanks to its perfect finish.

Ø150 MESH DISC

Model	Pcs.	Ø (mm)	Grain	-	Code
R0150 R0752 R05 Brushless	5	150	40	Mesh	12.844
	5	150	60	Mesh	12.682
	5	150	80	Mesh	12.683
	5	150	120	Mesh	12.684
	5	150	180	Mesh	12.685
	5	150	240	Mesh	12.686



Ø225 MESH DISC

Model	Pcs.	Ø (mm)	Grain	-	Code
HP1010 LP700 LP710E LP710DT LP1000	5	225	40	Mesh	12.845
	5	225	60	Mesh	12.839
	5	225	80	Mesh	12.687
	5	225	120	Mesh	12.688
	5	225	180	Mesh	12.689



ABRASIVE SANDING BELTS

BELT SANDING SHEET

Pcs.	(mm)	Grain	Code
3	75x457	40	12.804
3	75x457	60	12.805
3	75x457	80	12.806
3	75x457	120	12.807

Pcs.	(mm)	Grain	Code
3	75x533	40	12.269
3	75x533	60	12.270
3	75x533	80	12.271
3	75x533	120	12.808
3	75x533	150	12.273

Pcs.	(mm)	Grain	Code
3	100x610	40	12.274
3	100x610	60	12.275
3	100x610	80	12.276
3	100x610	100	12.277
3	100x610	150	12.278

Pcs.	(mm)	Grain	Code
3	100x690	40	12.840
3	100x690	60	12.841
3	100x690	80	12.842
3	100x690	120	12.809

Model	Pcs.	(mm)	Grain	Code
LT1401EK	10	40x760	40 INOX	12.846
	10	40x760	60 INOX	12.511
	10	40x760	80 INOX	12.512
	10	40x760	120 INOX	12.513



BELT SANDING SHEET

Model	Pcs.	(mm)	Grain	Code
ECL150B	5	50x686	80	8110.369

ABRASIVE SANDING SHEETS

DELTA SANDING SHEET

Model	Pcs.	(mm)	Grain	Code
LD141	10	80x140x140	40x2 - 60x3 - 80x3 - 120x2	12.446

Model	Pcs.	(mm)	Grain	Code
DELTA 150	10	100x150x150	40x2 - 60x3 - 80x3 - 120x2	12.675
	5	100x150x150	40	12.818
	5	100x150x150	60	12.819
	5	100x150x150	80	12.820
	5	100x150x150	120	12.821



- Specially designed to be attached to a delta plate to sand woods & plastics.
- Delta shape allows for corners and edge sanding.
- Compatible with MULTITOOL PRO300, MULTI L20 & MULTI L18 from STAYER .

Model	Pcs.	(mm)	Grain	Code
Multi Tool	10	93x93x93	40x2 - 60x3 - 80x3 - 120x2	12.556
	5	93x93x93	60	12.814
	5	93x93x93	80	12.815
	5	93x93x93	120	12.816
	5	93x93x93	180	12.817

Model	Pcs.	(mm)	Grain	Code
Multi Tool	10	95x135	60	12.810
	5	95x135	80	12.811
	5	95x135	120	12.812
	5	95x135	180	12.813



RECTANGULAR SANDING SHEET

Model	Pcs.	(mm)	Grain	Code
LOM 185 LOM180 LH 187 C LH 191	10	93x186	40x2 - 60x3 - 80x3 - 120x2	12.133
	10	93x186	40	12.127
	10	93x186	60	12.128
	10	93x186	80	12.129
	10	93x186	100	12.130
	10	93x186	150	12.131
	10	93x186	180	12.132

Model	Pcs.	(mm)	Grain	Code
LOM180 LH227E	10	115x230	40x2 - 60x3 - 80x3 - 120x2	12.696

Model	Pcs.	(mm)	Grain	Code
LOM130PD LOM130 3P	10	85x135	40x2 - 60x3 - 80x3 - 120x2	12.690



DOUBLE FACE SANDING SHEET

Model	Pcs.	(mm)	Grain	Code
LOM130PD LOM130 3P	10	85x260	40x2 - 60x3 - 80x3 - 120x2	12.692



DELTA SANDING SHEET

Model	Pcs.	(mm)	Grain	Code
LOM130PD LOM130 3P	10	90x225	40x2 - 60x3 - 80x3 - 120x2	12.694



ABRASIVE SANDPAPER SHEETS

PAPER SANDING SHEETS (WOOD)

Quartz sand.

 Minimum order 50 sheets (1 box)

Pcs.. Master box 	(mm)	Grain	Code
50	230x280	80	12.771
50	230x280	120	12.772
50	230x280	180	12.773



CLOTH SANDING SHEETS (METAL)

Aluminum oxide. Emery.

 Minimum order 50 sheets (1 box)

Pcs.. Master box 	(mm)	Grain	Code
50	230x280	60	12.774
50	230x280	80	12.775
50	230x280	120	12.776
50	230x280	180	12.777



WATER SANDING SHEETS

Kraft paper. Silicon carbide. CP34 water sanding sheets

 Minimum order 50 sheets (1 box)

Pcs.. Master box 	(mm)	Grain	Code
50	230x280	220	12.778
50	230x280	228	12.779
50	230x280	360	12.780
50	230x280	500	12.781
50	230x280	800	12.782
50	230x280	2000	12.783

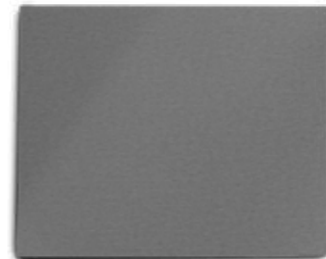

ABRASIVE ROLLS

PAPER SANDING ROLL

Length	Width (mm)	Grain	Code
5 M	115	60	12.796
5 M	115	80	12.797
5 M	115	120	12.798
5 M	115	180	12.799
25 M	115	60	12.800
25 M	115	80	12.801
25 M	115	120	12.802
25 M	115	180	12.803



CLOTH SANDING ROLL

Length	Width (mm)	Grain	Code
5 M	115	60	12.792
5 M	115	80	12.793
5 M	115	120	12.794
5 M	115	180	12.795



ABRASIVE SPONGES

ABRASIVE SPONGES

High density corundum sponges Flexible, washable & reusable.

For wood, plaster, glass, metal, porcelanic and paint. For curved and edge surfaces.

Pcs.	Width (mm)	Grain	Code
3	120x100x12	Fine	12.701
3	120x100x12	Medium	12.702
1	120x100x12	Medium	12.785
1	120x100x12	Fine	12.786



ABRASIVE BLOCKS

ABRASIVE BLOCKS

High density corundum abrasive blocks Stiff, washable & reusable. For wood, plaster, glass, metal, porcelanic and paint.

 (mm)	Grain	Code
5 100x70x25	Coarse	12.697
5 100x70x25	Medium	12.698
5 100x70x25	Fine	12.699
mixed 5 100x70x25	2x Coarse 1x Medium 1x Fine 1x Super Fine	2.700
1 100x70x25	Coarse	12.787
1 100x70x25	Medium	12.788
1 100x70x25	Fine	12.789



ANGLED ABRASIVE BLOCK

Pcs..	(mm)	Grain	Code
1	90x122x25	Fine	12.791
1	90x122x25	Medium	12.790



HAND SANDING CORK SUPPORT

Pcs..	(mm)	Code
1	110x65x30	12.784



GRINDING WHEELS

Model	Pcs.	(mm)	Grain	Use	Code
E150B	1	150x16x12,7	36	roughing / grinding	8110.371
E150B	1	150x16x12,7	60	sharpen / tuning	8110.370
E200B	1	200x20x16	36	roughing / grinding	8110.184
E200B	1	200x20x16	60	sharpen / tuning	8110.139
ECP150B	1	150x20x12,7	36	roughing / grinding	8110.364
ECA150B	1	200x40x20	80	sharpen / tuning	4104.1300



POLISHING PLATES

SELF ADHERING RUBBER PLATE

- Double insertion
- M14 for angle grinder
- Cylindrical shaft for drill

Model	∅ (mm)	Code
LU260CE PL2500E (Drill / angle grinder)	115	12.770
	125	12.767

Model	∅ (mm)	Code
LU260CE PL2500E (Drill / angle grinder)	150	12.509
	180	12.426



NYLON PLATE

Model	∅ (mm)	Code
LU260CE PL2500E	170	12.28



SELF ADHERING WOOL PADS

Model	∅ (mm)	Code
LU260CE PL2500E	125	12.764
	150	12.539
	180	11.5527
	180 (with rope)	12.87



SPONGE

Model	∅ (mm)	Code
LU260CE PL2500E	150	12.88



VACUUM CLEANER ACCESSORIES

BVAC 1420

Accessory	Code
HEPA Filter	12.997
Paper bag	12.998
Vacuum Hose	8190.194
Plastic tubes	8190.198
Brush	8190.196
Flat nozzle	8190.197
Cloth filter	8190.195



VAC 2030

Accessory	Code
Cloth filter	8190.102
HEPA Filter	8190.162
Filter Sponge	8190.101
Washable filter bag	8190.103



VAC 2050 C

Accessory	Code
Cloth filter	8190.97
HEPA Filter	8190.49
Vacuum hose	8190.99
Flat nozzle	8190.92
Vacuum brush	8190.94
Circular brush	8190.93
Vacuum tube	8190.91
Flexible hose	8190.95



VACUUM CLEANER ACCESSORIES

VAC 2030 VSYSTEM

Accessory	Code
Antistatic hose	8130.195
Long Square Brush (Wet and Dry)	8130.198
Brush	8130.200
Flat nozzle	8130.197
Telescopic Tube	8130.196
HEPA Filter	8130.180
Cloth Bag	8130.199



BVAC 2240 VSYSTEM / BVAC 2240 AIR V-SYSTEM

Accessory	Code
Two position brush	8130.338
Brush Semicircular	8130.324
HEPA Filter	12.1011
Hose	8130.326
Metal Telescopic Tube	8130.323
Cloth Bag	12.1012
Dust Bag	8130.297
Suction reducer	8130.350
Suction Adapter for sanders	8130.339
Remote Control	8130.348
Bracelet	8130.349



BVAC 2400 DM

Accessory	Code
HEPA Filter	12.714
Floor brush (liquids)	12.715
Floor brush (solids)	12.716
Flexible hose	12.713
Vacuum tube	12.712
Flat nozzle	12.718
Circular brush	12.717



HIGH PRESSURE CLEANERS ACCESSORIES

HL 105 B / HL 135

Accessory	Code
Gun	8276.412
Turbo lance	8276.564
Fan lance	8276.414
Conector	8276.413

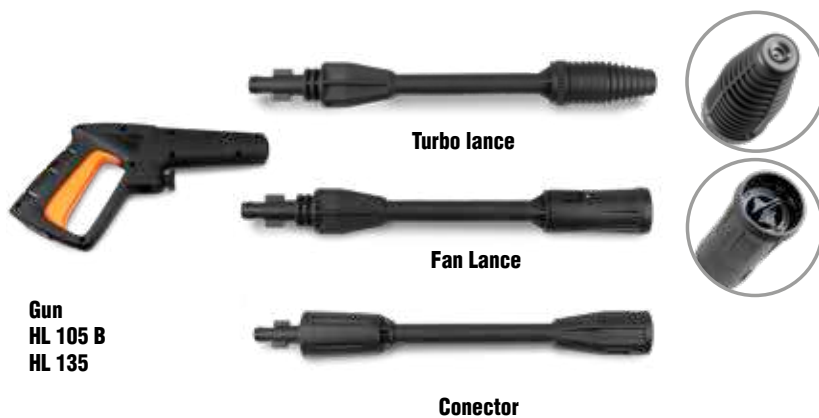

HL 145 / HL 2200 B

Accessory	Code
Gun	8276.1427
Turbo lance	8276.106
Foam tank	8276.1426
Turbo nozzle	8276.1430
Fan nozzle	8276.1431



HIGH PRESSURE CLEANERS ACCESSORIES

HL 2700 IND / HL 2700 B IND / HL 2700 IND C

Accessory	Code
Gun	8276.53
Turbo lance	8276.565
Fan lance	8276.566

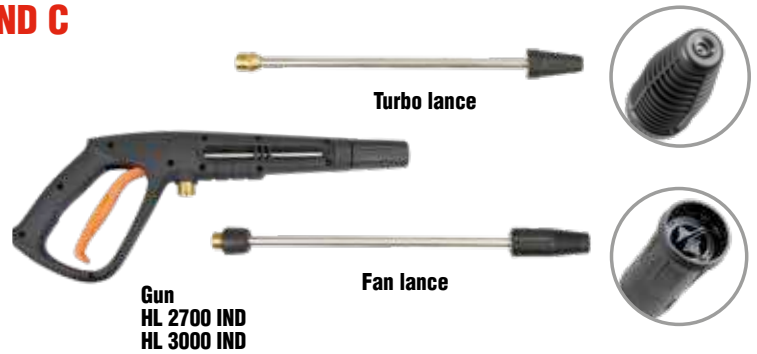

HL 3000 B IND / HL 11 B IND

Accessory	Code
Gun	8276.53
Intermediate lance	8276.567
Nozzle 0°	8276.88
Nozzle 15°	8276.90
Nozzle 25°	8276.89
Nozzle 40°	8276.91
Nozzle Soap	8276.562
Nozzle turbo	8276.93



HL 2000 PSI

Accessory	Code
Fan lance	8276.680
Gun	8276.679
Turbo lance	8276.106



HIGH PRESSURE CLEANERS ACCESSORIES

HL 105 B / HL 2000 / HLC 2000 / HL 2200 IND / HL 135 / HL 2200

Accessory	Code
Brush	8276.326
Floor brush 200mm	8276.325
Flushing pipe 6m	8276.324
Rotary brush	8276.323
Foam tank	8276.651



HL 2700 IND / HL 3000 IND / HL 2700 B IND/ HL 2700 IND C

Accessory	Code
Rotary brush	8276.426
Floor brush 200mm	8276.652
Flushing pipe + Adaptor	8276.654
Adaptor	8276.653
Extensor hose 5m	8276.571
Brush adaptor	8276.563
Foam tank	8276.650



COMMON ACCESSORIES

Accessory	Code
Water filter	8276.343
HPC conector	8276.327

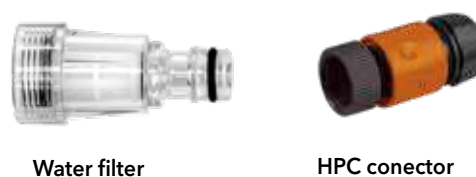

STAYER IBÉRICA S.A.
Street Sierra de Cazorla, 7
Área Empresarial, Sector 1
28320 Pinto (Madrid) España

Phone.: +34 91 691 86 30

email:
helpdesk@grupostayer.com

www.stayer.es

STAYER srl
36015 Schio (VI) Italia
Via Lago di Costanza, 20

Tel.: +39 0445 621 244

email:
info@stayeritalia.it

www.stayeritalia.it

This catalog is intended for Export.
The photographs in this catalog are purely indicative.
The company reserves the modify or change them without prior notice.
©2026 - Stayer Group - Design and Marketing Department.

English • 02 / 2026

